



Catalog Number 5860018

Hach sc100™ Controller

USER MANUAL

March 2007, Edition 6

Table of Contents

- Section 1 Specifications** 3

- Section 2 General Information** 5
 - 2.1 Safety Information 5
 - 2.1.1 Use of Hazard Information 5
 - 2.1.2 Precautionary Labels 5
 - 2.2 General Product Information 5

- Section 3 Installation** 7
 - 3.1 Mechanical Installation 9
 - 3.1.1 Controller Dimension Illustrations 9
 - 3.1.2 Mounting the Controller 11
 - 3.2 Wiring Safety Information 13
 - 3.2.1 Electrostatic Discharge (ESD) Considerations 13
 - 3.3 Electrical Installation 13
 - 3.3.1 Installation in Conduit 14
 - 3.3.2 Installation Using a Power Cord 14
 - 3.3.3 Wiring for Power at the Controller 15
 - 3.4 Alarms and Relays 18
 - 3.4.1 Connecting the Relays 18
 - 3.4.2 Connecting the Analog Outputs 19
 - 3.5 Connecting/Wiring the sc Sensor 20
 - 3.5.1 Connecting the sc Sensor in a Non-hazardous Location 20
 - 3.5.2 Connecting the sc Sensor to a Controller in a Hazardous Location 22
 - 3.6 Wiring the Digital Gateway 23
 - 3.7 Connecting the Optional Digital Output 23

- Section 4 Operation** 27
 - 4.1 Using the Keypad 27
 - 4.2 Controller Display Features 28
 - 4.2.1 Important Key Presses 28
 - 4.3 System Setup 29
 - 4.3.1 Adjusting Display Contrast 29
 - 4.3.2 Specifying the Displayed Language 29
 - 4.2.2 Software Text Abbreviations 29
 - 4.3.3 Setting the Time and Date 30
 - 4.4 Setting up System Security 31
 - 4.4.1 Setting the Passcode 31
 - 4.4.2 Editing the Passcode 31
 - 4.5 Output Options 32
 - 4.5.1 Navigating to the Output Options Menu 32
 - 4.5.2 Hold/Transfer Outputs 32
 - 4.5.3 Release Outputs 33
 - 4.6 Relay Options 33
 - 4.6.1 Navigating to the Relay Options Menu 33
 - 4.7 Data Event Logging Options 33
 - 4.8 Digital Network Options 34
 - 4.9 System Setup Menu 34
 - 4.10 Test/Maint Menu 38

- Section 5 Maintenance** 39
 - 5.1 Cleaning the Controller 39
 - 5.2 Fuse Replacement 39

Table of Contents

Section 6 Replacement Parts and Accessories	41
6.1 Replacement Items	41
6.2 Accessories.....	41
Section 7 Compliance Information	43
Section 8 How to Order	45
Section 9 Repair Service	46
Section 10 Limited Warranty	47

Section 1 Specifications

Specifications are subject to change without notice.

Component Description	Microprocessor-controlled measuring unit with measured value display, temperature display, and menu-driven system
Controller Operating Temperature	–20 to 60 °C (–4 to 140 °F); 95% relative humidity, non-condensing with sensor/network card load <7 W; –20 to 40 °C (–4 to 104 °F) with sensor /network card load <25 W
Controller Storage Temperature	–20 to 70 °C (–4 to 158 °F); 95% relative humidity, non-condensing
Enclosure	NEMA 4X/IP66 metal enclosure with a corrosion-resistant finish
Power Requirements	AC Powered sc100 model: 100–230 VAC ±10%, 50/60 Hz; Power 15 W with 7 W sensor/network card load, 37 W with 25 W sensor/network card load
	24 VDC powered sc100 model: 24 VDC –15%, +20%; Power 16W with 7W sensor/network card load, 34 W with 25 W sensor/network card load
Pollution Degree/ Installation Category	II; II
Outputs	Two (Analog (4–20 mA)) outputs, maximum impedance 500 ohm. Optional digital network connection. IrDA digital connection.
Relays	Three SPDT, user-configured contacts rated 100–230 VAC, 5 Amp resistive maximum for the ac powered sc100 and 24 VDC, 5A resistive maximum for the dc powered sc100.
Controller Dimensions	½ DIN—144 x 144 x 150 mm (5.7 x 5.7 x 5.9 inches)
Controller Weight	1.6 kg (3.5 lb)
Certifications	CE approved (with all sensor types) Listed for use in general locations to UL and CSA safety standards by ETL (with all sensor types) Listed for use in Class I, Division 2 hazardous locations to FM & CSA safety standards by ETL (with specified sensor types, per Control Drawing 58600-78)

Section 2 General Information

2.1 Safety Information

Please read this entire manual before unpacking, setting up, or operating this equipment. Pay attention to all danger and caution statements. Failure to do so could result in serious injury to the operator or damage to the equipment.

To ensure that the protection provided by this equipment is not impaired, do not use or install this equipment in any manner other than that specified in this manual.

2.1.1 Use of Hazard Information

DANGER

Indicates a potentially or imminently hazardous situation which, if not avoided, could result in death or serious injury.

CAUTION





Indicates a potentially hazardous situation that may result in minor or moderate injury.

Important Note: *Information that requires special emphasis.*

Note: *Information that supplements points in the main text.*

2.1.2 Precautionary Labels

Read all labels and tags attached to the instrument. Personal injury or damage to the instrument could occur if not observed

	This symbol, if noted on the instrument, references the instruction manual for operation and/or safety information.
	This symbol, when noted on a product enclosure or barrier, indicates that a risk of electrical shock and/or electrocution exists.
	This symbol, if noted on the product, indicates the need for protective eye wear.
	This symbol, when noted on the product, identifies the location of the connection for Protective Earth (ground).
	This symbol, when noted on the product, identifies the location of a fuse or current limiting device.

2.2 General Product Information

The controller enclosure is NEMA4X/IP66-rated and has a corrosion-resistant finish designed to withstand corrosive environmental constituents such as salt spray and hydrogen sulfide. The controller display shows the current reading plus a secondary measurement such as temperature if connected to a single sensor, or two readings with their corresponding secondary measurement readings when two sensors are connected.

Installation instructions for the controller are presented in this manual. If a system with a sensor and a controller has been purchased, complete information for installation and operation is also presented in the sensor system manual.

Section 3 Installation

DANGER

Only qualified personnel should conduct the installation tasks described in this section of the manual. This equipment is suitable for use in non-hazardous locations or Class 1, Division 2, Groups A, B, C, D Hazardous Locations with specified sensors and options when installed per the [Hazardous Location Installation Control Drawing on page 8](#). Always refer to the Control Drawing and applicable electrical code regulations for proper installation instructions.

DANGER

Explosion hazard. Substitution of components may impair suitability for Class 1, Division 2. Do not replace any component unless power has been switched off and the area is known to be non-hazardous.

Figure 1 Components of a Basic System

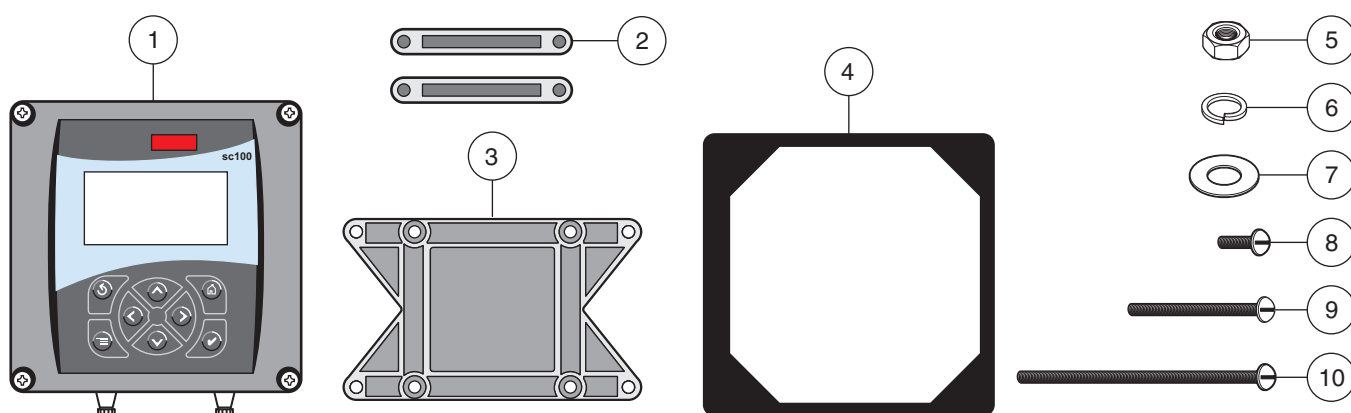

1. Controller	6. Lock washer, ¼-inch I.D. (4), Cat. No. 8H1336
2. Mounting foot for panel mounting (2), Cat. No. 1000B4F3222	7. Flat washer, ¼-inch I.D. (4), Cat. No. 8H1346
3. Bracket for panel & pipe mounting, Cat. No. 1000C4F3217-101	8. Pan head screws (4), M6 x 1.0 x 20 mm, Cat. No. 5867400
4. Gasket for panel mounting, Neoprene, Cat. No. 1000A4F3249-101	9. Pan head screws (4), M6 x 1.0 x 100 mm, Cat. No. 5867500
5. Hex nut, M6 (4), Cat. No. 5867300	10. Pan head screws (4), M6 x 1.0 x 150 mm, Cat. No. 5867600

Table 1 Customer-supplied Items

Item
14-AWG wire for electrical power connections in conduit or 115 or 230 V ac power cord plus a NEMA 4X-rated strain relief
High-quality, shielded instrumentation cable for connecting the analog outputs plus a NEMA 4X-rated strain relief.
Mounting hardware for the sensor (available from the manufacturer, order separately). See the sensor manual.
Sun shield for mounting configurations where the sun strikes the front of the display.
Common hand tools

Figure 2 Hazardous Location Installation Control Drawing

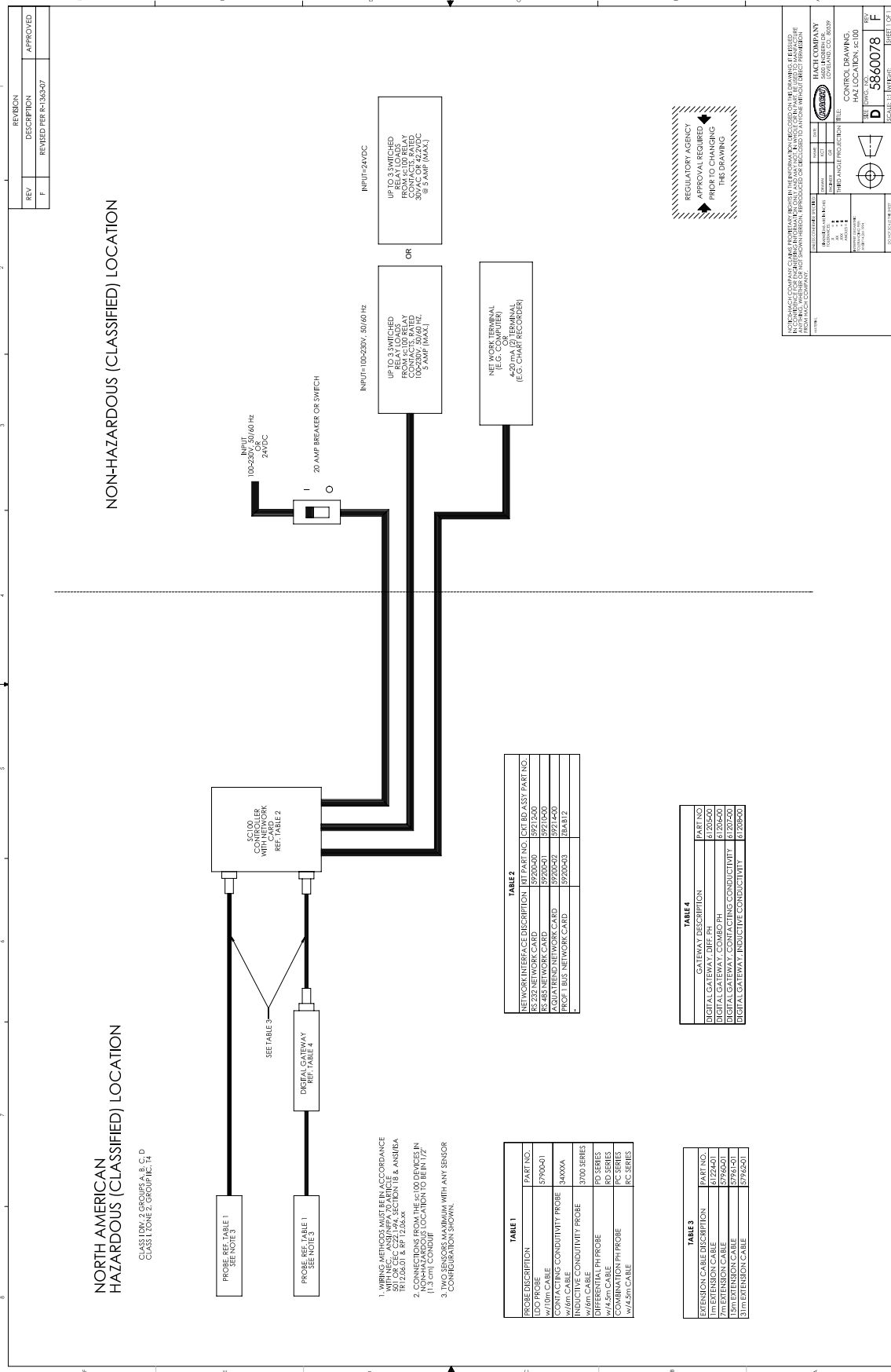

REV	DESCRIPTION	APPROVED
F	REVISED PER FC156497	

TACH COMPANY LONGMANS CO. 8039	
SCALE	1:1
PROJ. NO.	5860078
DATE	
BY	
CHECKED BY	
APPROVED BY	
PROJECT NO.	
SHEET NO.	F
TOTAL SHEETS	

NETWORK INTERFACE DESCRIPTION	MT PART NO.	OC BOARD SVT PART NO.
RS 232 NETWORK CARD	5720040	5721240
RS 485 NETWORK CARD	5720041	5721040
AGUA TREN NETWORK CARD	5720042	5721420
PROFIBUS NETWORK CARD	5720043	584312

GATEWAY DESCRIPTION	PART NO.
DIGITAL GATEWAY, DIFF. PH.	6126420
DIGITAL GATEWAY, COMBO PH.	6126440
DIGITAL GATEWAY, CONTACTING CONDUCTIVITY	6126740
DIGITAL GATEWAY, INDUCTIVE CONDUCTIVITY	6126940

PROBE DESCRIPTION	PART NO.
LOG PROBE	5790041
w/10m CABLE	580004
CONTACTING CONDUCTIVITY PROBE	3700 SERIES
INDUCTIVE CONDUCTIVITY PROBE	RD SERIES
DIFFERENTIAL PH PROBE	RD SERIES
w/4.5m CABLE	PC SERIES
COMBINATION PH PROBE	PC SERIES
w/4.5m CABLE	PC SERIES

EXTENSION CABLE DESCRIPTION	PART NO.
7m EXTENSION CABLE	5796401
15m EXTENSION CABLE	5796401
31m EXTENSION CABLE	5796401

1. WIRING METHODS MUST BE IN ACCORDANCE WITH THE NATIONAL ELECTRICAL CODE (NEC) 90, 91, 92, 93, 94, SECTION 518 & ANSI/ISA IEC 708.01 & RP 1205.XX
2. NON-HAZARDOUS LOCATIONS TO BE IN I/2 (11.3 cm) CONDUIT
3. TWO SENSORS MAXIMUM WITH ANY SENSOR COMBINATIONS SHOWN.

3.1 Mechanical Installation

Install in an environment that is protected from corrosive fluids.

3.1.1 Controller Dimension Illustrations

Figure 3 Controller Dimensions

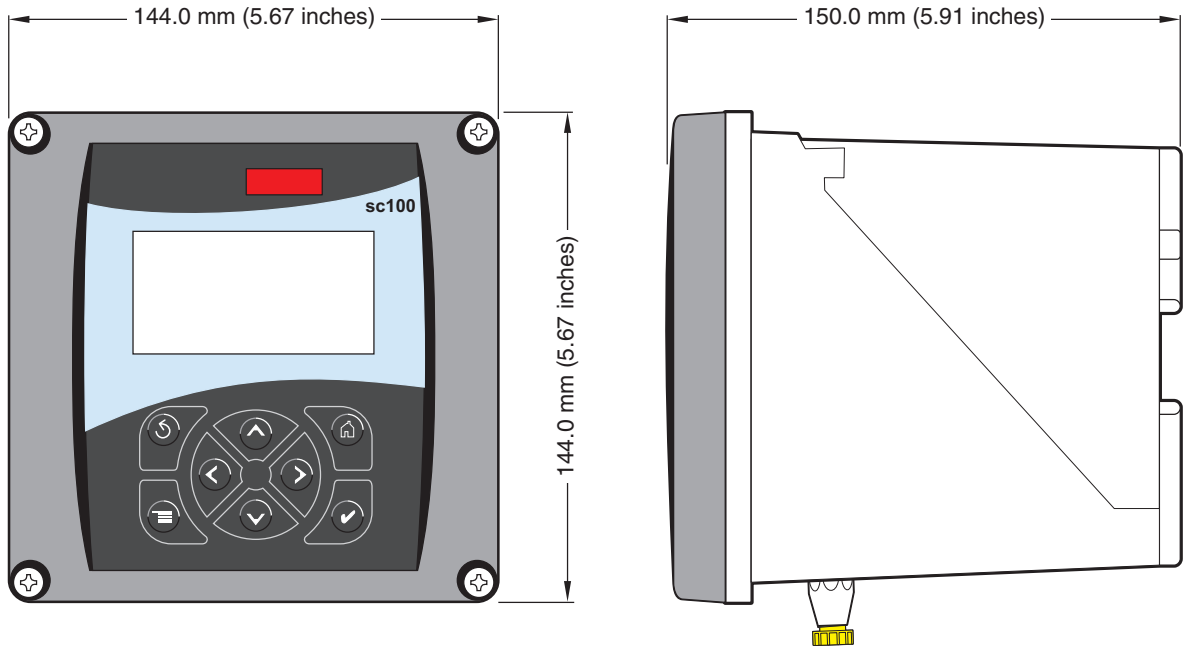

Figure 4 Controller Mounting Dimensions

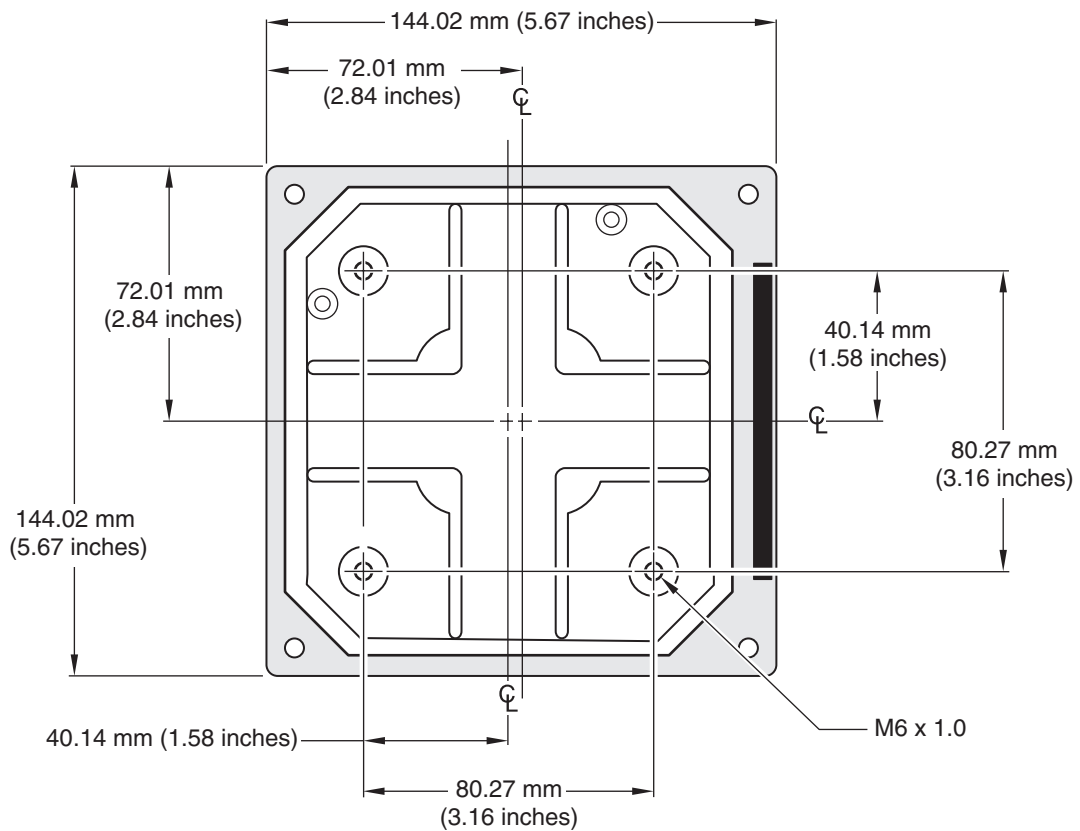

Figure 5 Panel Mount Cut-out Dimensions

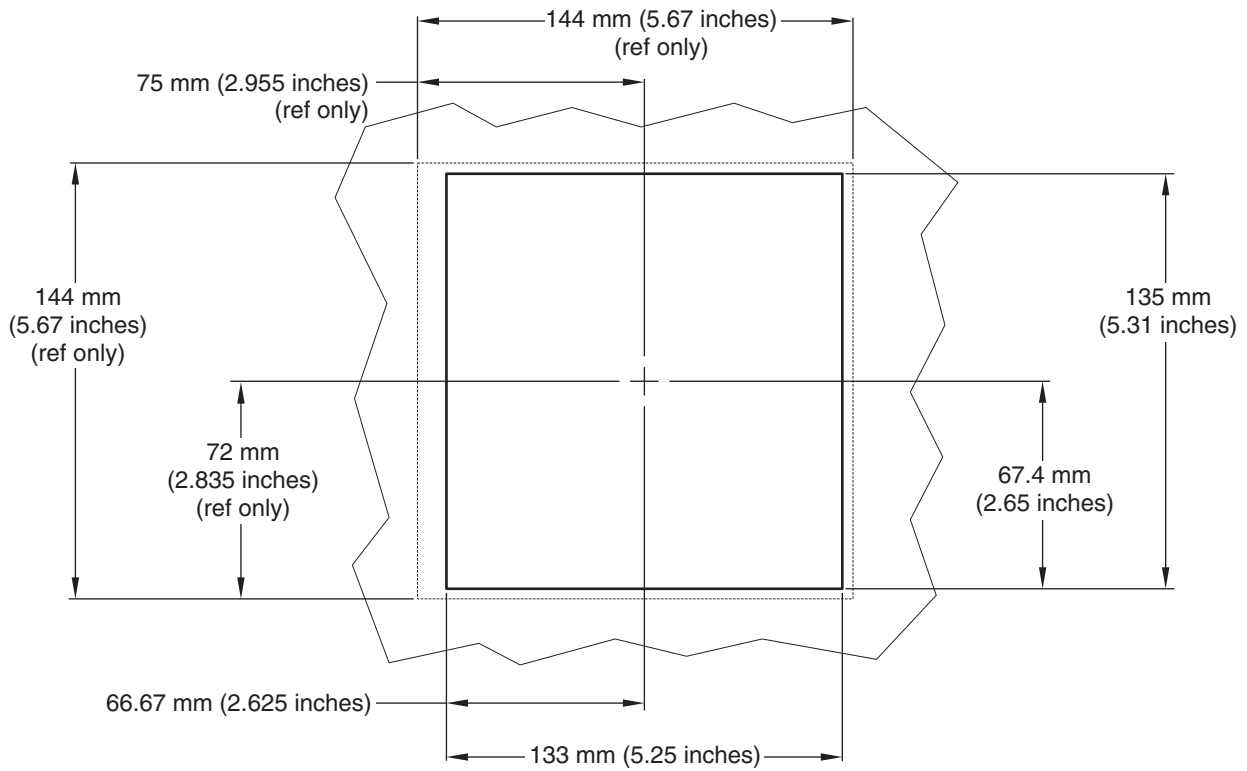
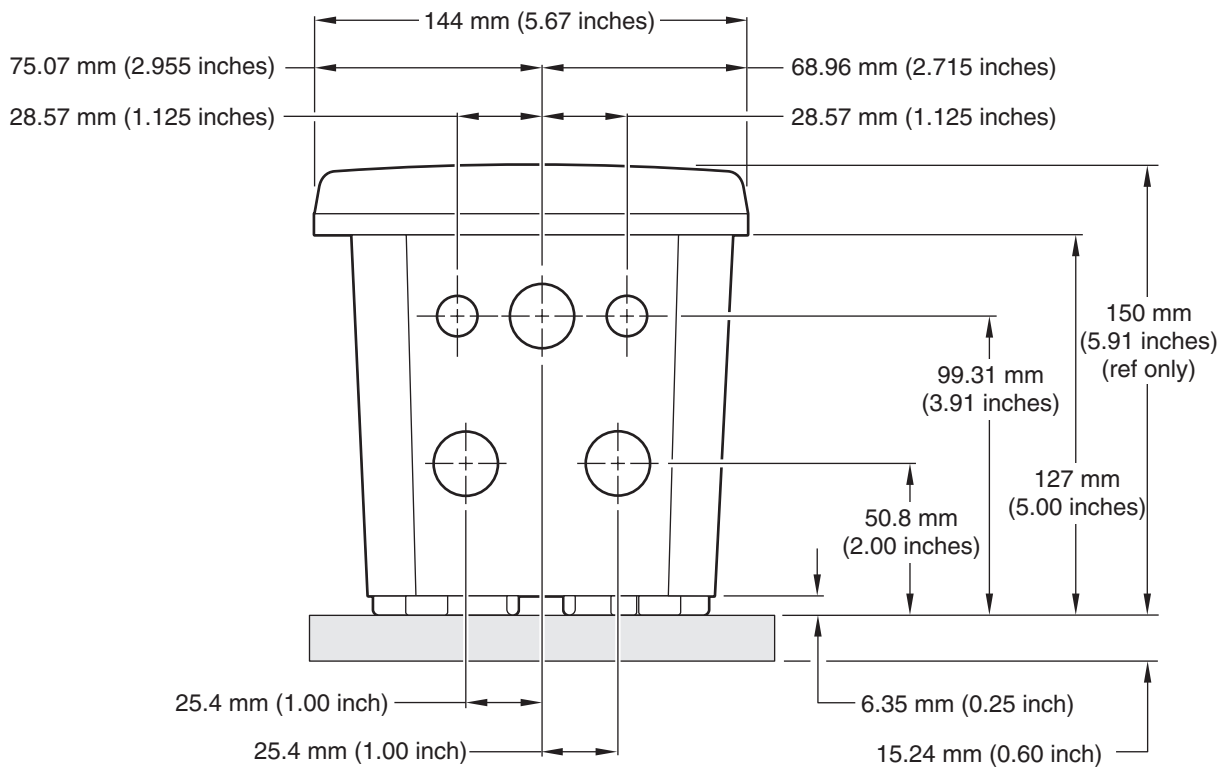

Figure 6 Conduit Hole Dimensions



3.1.2 Mounting the Controller

Attach the controller to a rail or wall or mount it in a panel. Supplied mounting hardware is shown in [Figure 7](#), [Figure 8](#), and [Figure 9](#).

Figure 7 Vertical or Horizontal Pipe Mounting the Controller

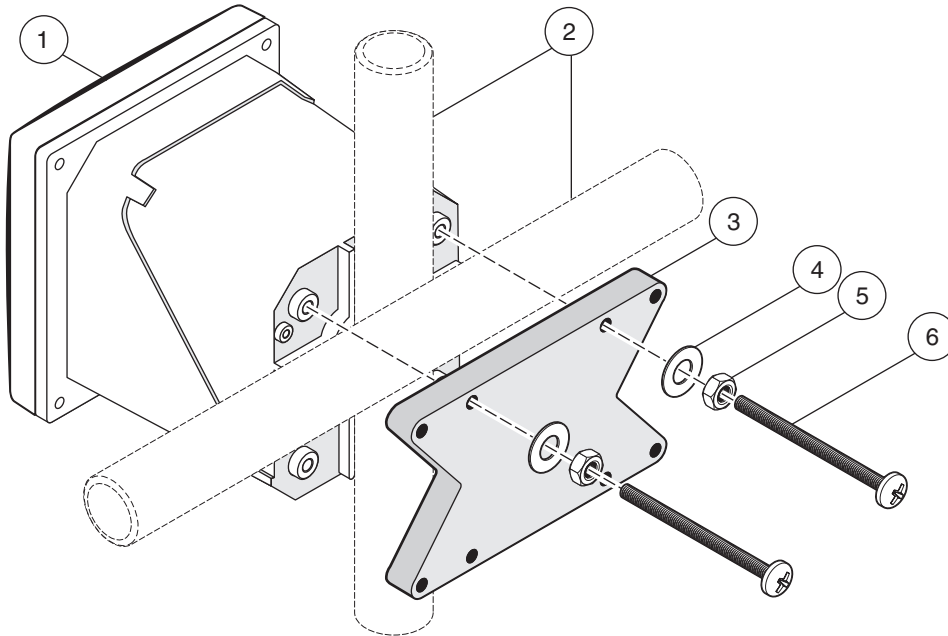

1. Controller	4. Flat washer, ¼-inch I.D. (4), Cat. No. 8H1346
2. Pipe (vertical or horizontal)	5. Hex nut, M6 (4), Cat. No. 5867300
3. Bracket, pipe mounting, Cat. No. 1000C4F3217-101	6. Pan head screw, M6 x 1.0 x 100 mm (4), Cat. No. 5867400

Figure 8 Wall Mounting the Controller

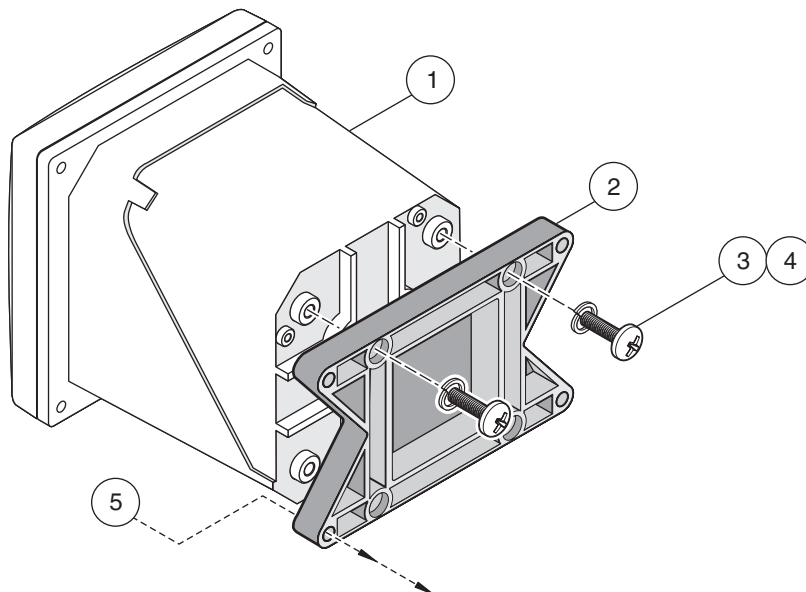

1. Controller	4. Pan head screw, M6 x 1.0 x 20 mm (4), Cat. No. 5867400
2. Bracket, Cat. No. 1000C4F3217-101	5. Customer-supplied hardware for wall mounting
3. Lock washer, ¼-inch I.D., Cat. No. 8H1336	

Figure 9 Panel Mounting the Controller

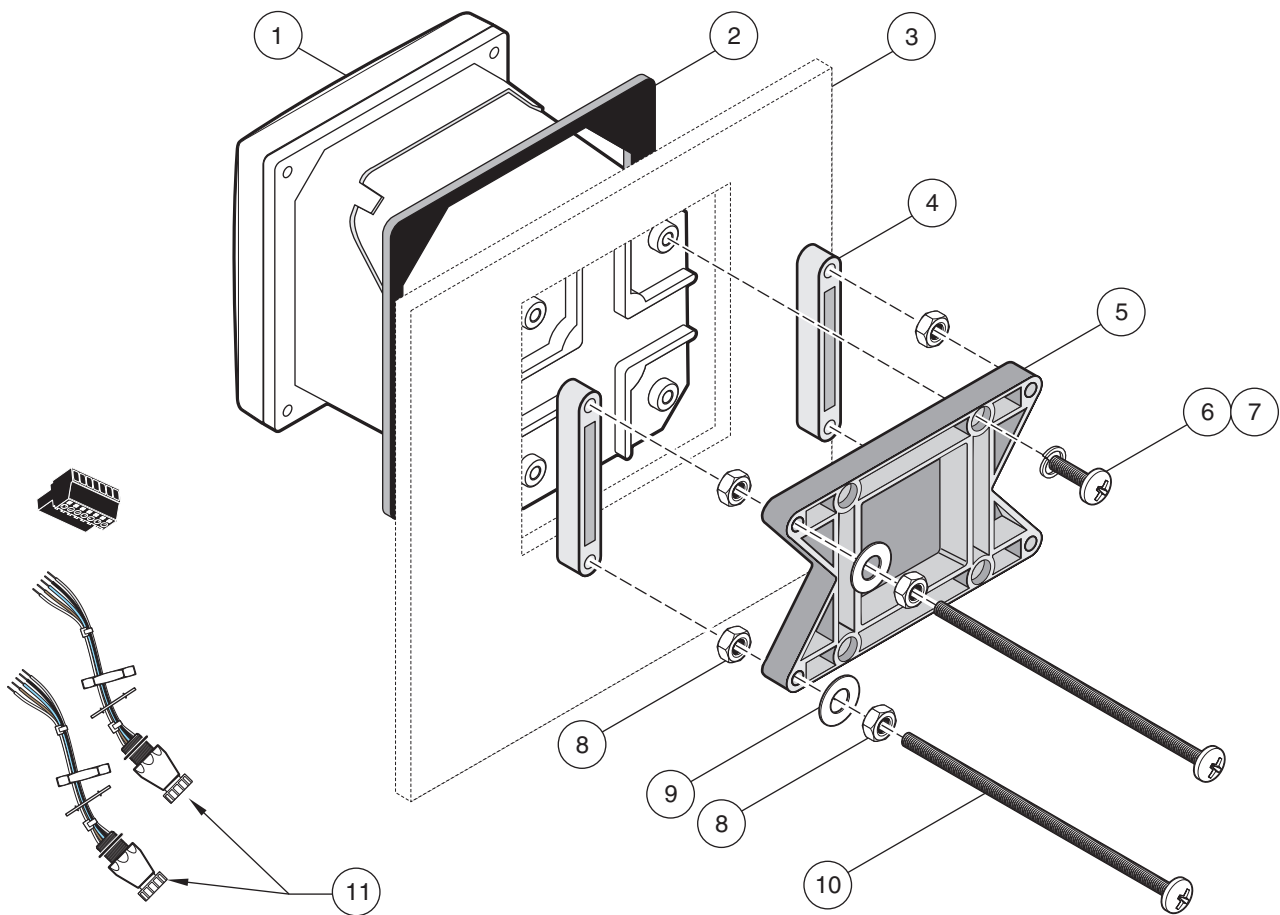

1. Controller	7. Lock washer, ¼-inch I.D., (4) Cat. No. 8H1336
2. Gasket, Neoprene, panel mount, Cat. No. 1000A4F3249-101	8. Hex nut (4), Cat. No. 5867300
3. Panel (maximum thickness is 9.5 mm (3/8 inch))	9. Flat washer (4), Cat. No. 8H1346
4. Mounting Foot (2), Cat. No. 1000B4F3222	10. Pan head screw, M6 x 1.0 x 150 mm (4), Cat. No. 5867600
5. Mounting bracket, controller, Cat. No. 1000C4F3217-101	11. It may be necessary to remove the sensor connectors. see procedure below.
6. Pan head screw (4), Cat. No. 5867400	

To remove the sensor connectors before inserting the controller enclosure into the panel cut-out:

1. Disconnect the wires at terminal block J5, see [Figure 19 on page 22](#).
2. Loosen and remove the nut securing the sensor connector inside the enclosure. Remove the sensor connector and wires. Repeat step 1 and 2 for the other sensor connector.
3. After the controller is in place in the panel, reinstall the sensor connectors and reconnect the wiring to terminal J5 as shown in [Figure 19 on page 22](#).

3.2 Wiring Safety Information

When making any wiring connections to the sc100 Controller, the following warnings and must be adhered to, as well as, any warnings and notes found throughout the individual installation sections. For more safety information refer to [Safety Information on page 5](#).

DANGER

Always disconnect power to the instrument when any making electrical connections.

3.2.1 Electrostatic Discharge (ESD) Considerations

Important Note: *To minimize hazards and ESD risks, maintenance procedures not requiring power to the analyzer should be performed with power removed.*

Delicate internal electronic components can be damaged by static electricity, resulting in degraded instrument performance or eventual failure.

The manufacturer recommends taking the following steps to prevent ESD damage to your instrument:

- Before touching any instrument electronic components (such as printed circuit cards and the components on them) discharge static electricity from your body. This can be accomplished by touching an earth-grounded metal surface such as the chassis of an instrument, or a metal conduit or pipe.
- To reduce static build-up, avoid excessive movement. Transport static-sensitive components in anti-static containers or packaging.
- To discharge static electricity from your body and keep it discharged, wear a wrist strap connected by a wire to earth ground.
- Handle all static-sensitive components in a static-safe area. If possible, use anti-static floor pads and work bench pads.

3.3 Electrical Installation

DANGER

This equipment is suitable for use in non-hazardous locations or Class 1, Division 2, Groups A, B, C, D Hazardous Locations with specified sensors and options when installed per the [Hazardous Location Installation Control Drawing on page 8](#). Always refer to the Control Drawing and applicable electrical code regulations for proper installation instructions.

High-voltage wiring for the controller is conducted behind the high voltage barrier in the controller enclosure. The barrier must remain in place unless a qualified installation technician is installing wiring for power, alarms, or relays. See [Figure 10](#) for barrier removal information.

Figure 10 Removing Voltage Barrier

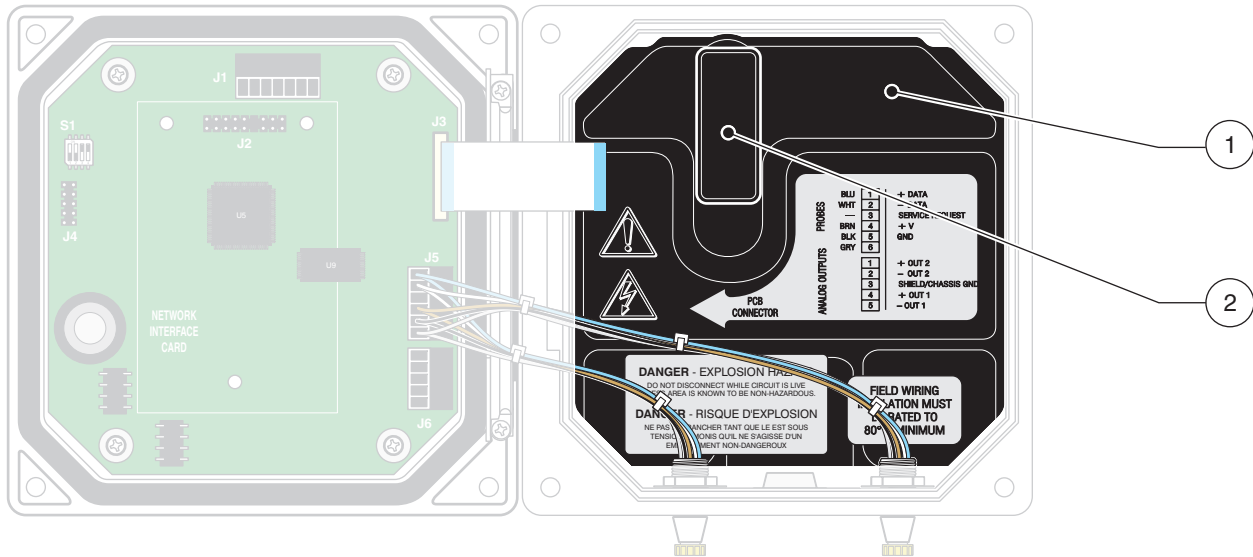

- | | |
|-------------------------|--|
| 1. High voltage barrier | 2. Unsnap the barrier latch then pull out to remove the barrier. |
|-------------------------|--|

3.3.1 Installation in Conduit

In hard-wired electrical applications, the power and safety ground service drops for the instrument must be 18 to 12 AWG. See [Figure 11 on page 14](#) for strain relief and conduit opening sealing plug information. See [section 3.3.3 on page 15](#) for wiring information.

3.3.2 Installation Using a Power Cord

DANGER
Use of a power cord is not acceptable in Class 1, Division 2 Hazardous Location Installation (see [Hazardous Location Installation Control Drawing on page 8](#)).

A sealing-type strain relief to maintain the NEMA 4X/IP66 environmental rating and a power cord less than 3 meters (10 feet) in length with three 18-gauge conductors (including a safety ground wire) can be used, see [Replacement Parts and Accessories on page 41](#). See [Figure 11 on page 14](#) for strain relief and conduit opening sealing plug assembly. See [section 3.3.3 on page 15](#) for wiring information.

Figure 11 Using the Optional Strain Relief and Conduit Plug

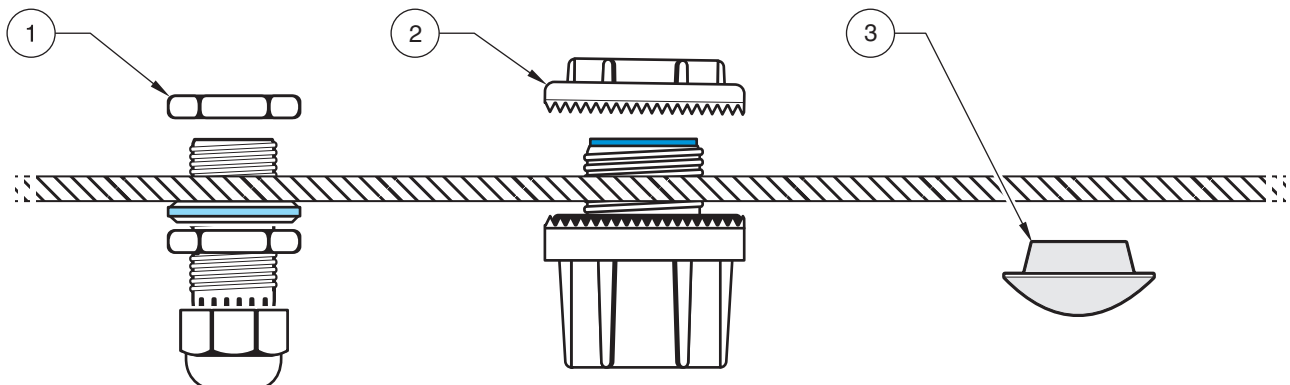

- | | | |
|-----------------------------|--------------------------|---------------------------------|
| 1. Power cord strain relief | 2. Conduit strain relief | 3. Conduit opening sealing plug |
|-----------------------------|--------------------------|---------------------------------|

3.3.3 Wiring for Power at the Controller

DANGER

Explosion hazard. Do not connect or disconnect electrical components or circuits to the equipment unless power has been switched off or the area is known to be non-hazardous.

DANGER

Do not connect AC power to a sc100 24 VDC powered model.

The sc100 can be purchased as either an 100–230 VAC powered model or a 24 VDC powered model. Follow the appropriate wiring instructions per the purchased model.

Important Note: A protective earth (PE) ground connection is required by the sc100 for **both** 100–230 VAC and 24 VDC wiring applications. Failure to connect a good PE ground connection can result in shock hazards and poor performance due to electromagnetic interferences. **ALWAYS** connect a good PE ground to the sc100 terminal.

The controller can be wired for line power by hard-wiring in conduit or wiring to a power cord. Regardless of the wire used, the connections are made at the same terminals. A local disconnect designed to meet local electrical code is required and must be identified for all types of installation. See [Figure 14](#) and [Figure 15 on page 17](#) for suggested local disconnect configurations.

1. Obtain appropriate fittings with NEMA 4X/IP66 environmental rating.
2. Loosen the screws using a phillips-head screwdriver and open the hinged controller cover.
3. Remove the high-voltage barrier (see [Figure 10 on page 14](#)).
4. Insert the wires through the strain relief fitting or conduit hub located in the right-rear access hole in the bottom of the enclosure. Tighten the strain relief if used, to secure the cord.
5. Properly prepare each wire ([Figure 12](#)) and insert each wire into the terminal according to [Table 2](#) or [Table 3](#). Tug gently after each insertion to ensure the connection is secure.
6. Seal any unused openings in the controller box with conduit opening sealing plugs.
7. Reinstall the high-voltage barrier and latch to secure.

Figure 12 Proper Wire Preparation and Insertion

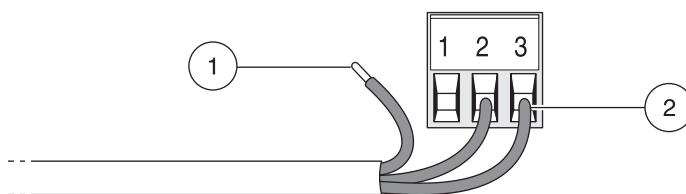

1. Strip ¼-inch of insulation.

2. Seat insulation against connector with no bare wire exposed.

Installation

Table 2 AC Power Wiring Information (sc100 AC powered model only)

Terminal Number	Terminal Description	Wire Color Code for North America	Wire Color Code for Europe
1	Hot (L1)	Black	Brown
2	Neutral (N)	White	Blue
3	Protective Earth (PE)	Green	Green w/yellow tracer

Table 3 DC Power Wiring Information (sc100 24 VDC powered model only)

Terminal Number	Terminal Description	Wire Color Code for North America	Wire Color Code for Europe
1	+24 V dc	Red	Red
2	24 V dc return	Black	Black
3	Protective Earth (PE)	Green	Green w/yellow tracer

The DC power source that supplies power to the 24 VDC powered sc100 must maintain voltage regulation within the specified 24 VDC $-15\% +20\%$ voltage limits. The DC power source must also provide adequate protection against surges and line transients.

Figure 13 sc100 Wiring Connections

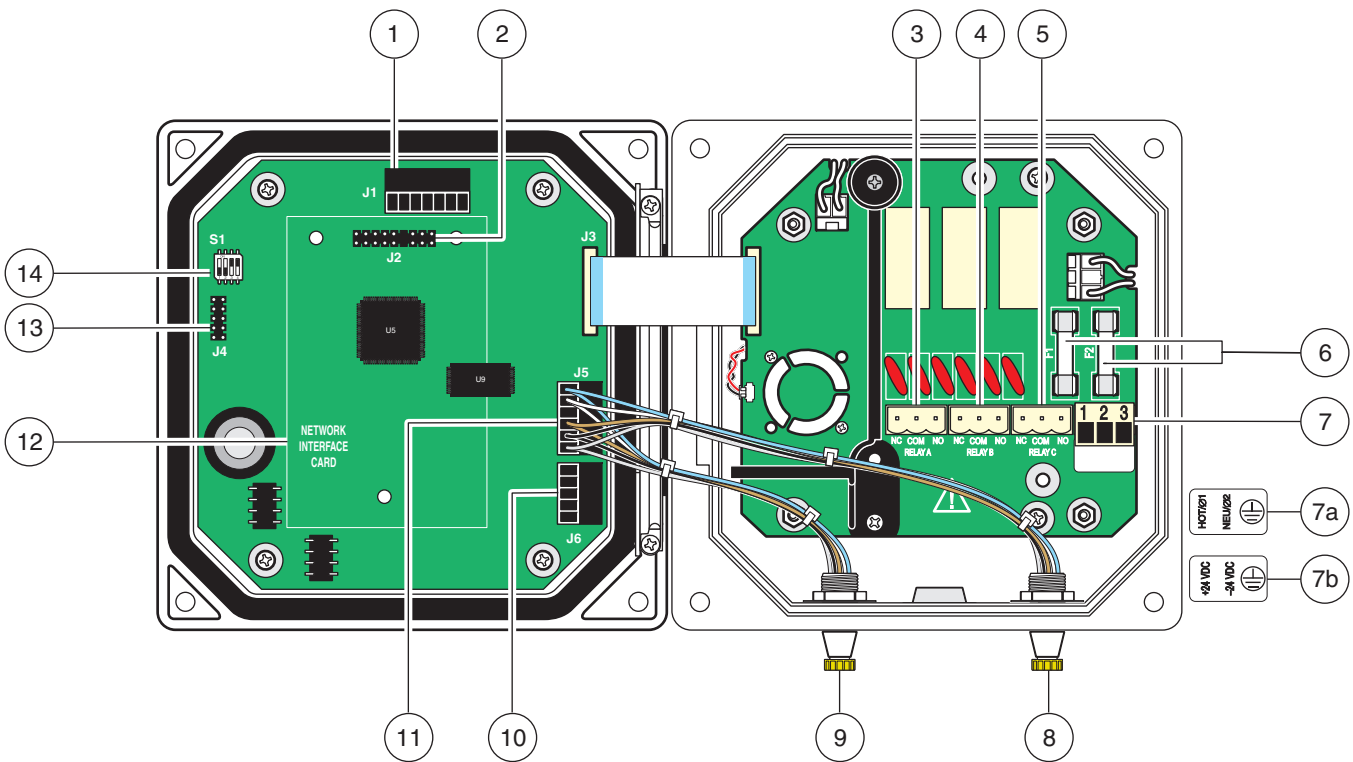

1. J1—Network connector	8. Sensor connector
2. J2—Header for optional network interface card	9. Sensor connector
3. J5—Relay A connector	10. J6—Analog output (4–20 mA) connector
4. J6—Relay B connector	11. J5—Sensor connector for hard-wiring
5. J7—Relay C connector	12. Position for network interface card
6. Fuses (F1, F2)	13. Service port
7. J8—Power connections	14. Sensor terminator selector/service port configuration
a. AC Power connection (AC powered sc100 model only)	
b. DC Power connection (24 VDC sc100 model only)	

Figure 14 Local Disconnect for Power Cord

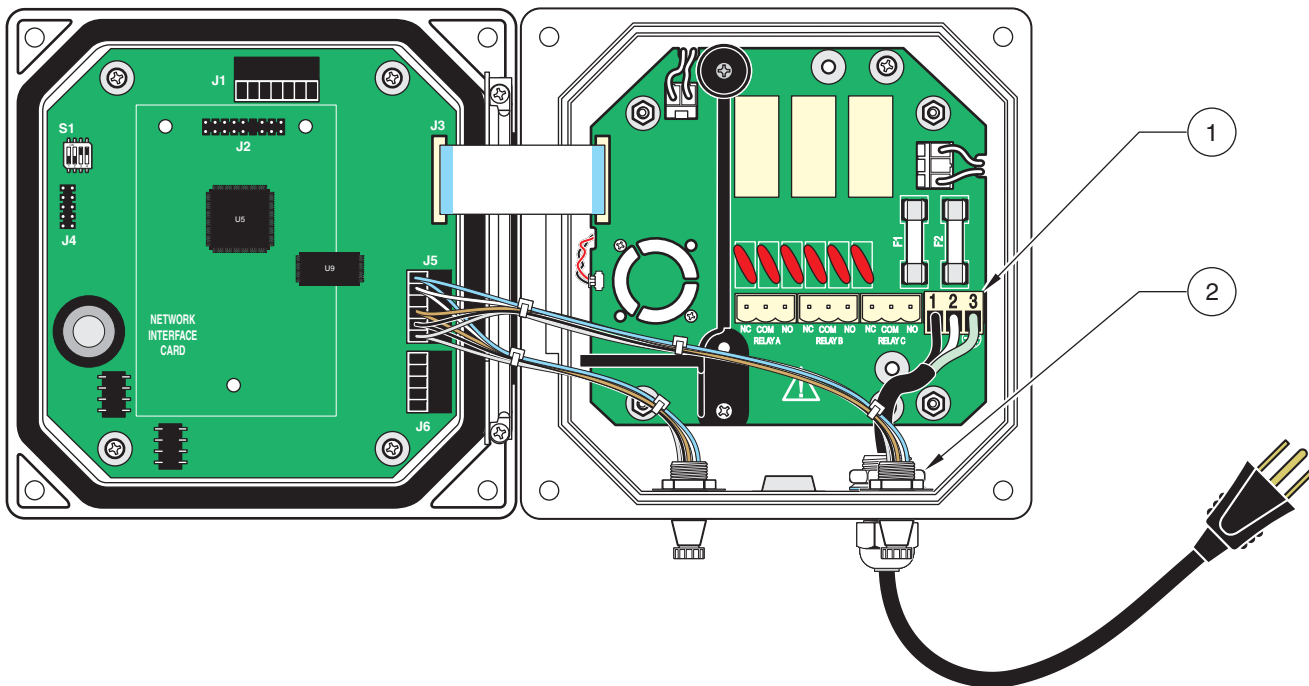

1. Power terminal

2. Power cord strain relief

Figure 15 Local Disconnect for Hard-wired Line Power

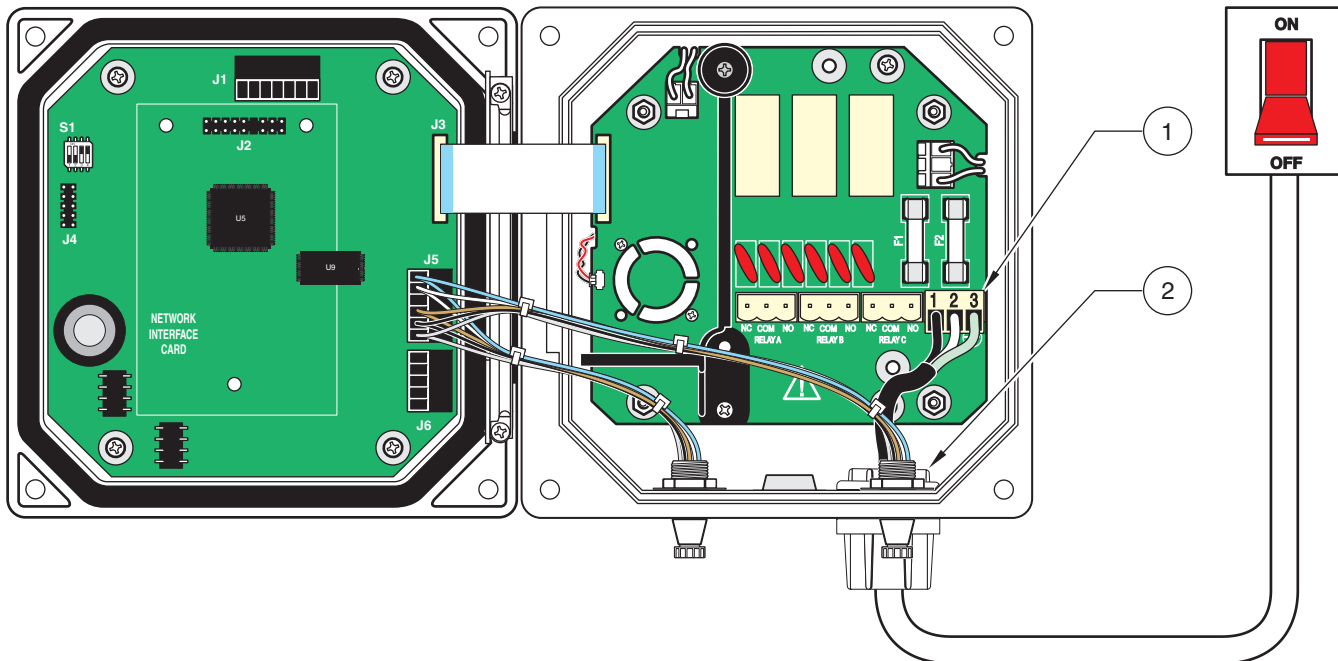

1. Power terminal

2. Conduit strain relief

3.4 Alarms and Relays

DANGER

Explosion hazard. Do not connect or disconnect electrical components or circuits to the equipment unless power has been switched off or the area is known to be non-hazardous.

DANGER

For Class 1, Division 2 Hazardous Location installations, refer to the Control Drawing ([Figure 2 on page 8](#)) for permanent connection requirements for the alarm relays.

DANGER

Exposure to some chemicals may degrade the sealing properties of materials used in the following devices: Relays K1, K2, and K3. Periodic inspection of these devices is recommended to check for degradation.

The controller is equipped with three unpowered relays rated 100–230 VAC, 50/60 Hz, 5 amp resistive maximum. See the sensor manual for relay setup details.

3.4.1 Connecting the Relays

DANGER

Relay loads must be resistive. User must externally limit current to the relays to 5 Amps by use of a fuse or breaker.

DANGER

Power and relay terminals are designed for only single wire termination. Do not use more than one wire in each terminal.

The relay connector accepts 18–12 AWG wire (as determined by load application). Wire gauge less than 18 AWG is not recommended.

The Normally Open (NO) and Common (COM) relay contacts will be connected when an alarm or other condition is active. The Normally Closed (NC) and Common relay contacts will be connected when an alarm or other condition is inactive or when power is removed from the controller.

AC Line (100–230 V) Powered sc100's

AC line powered sc100 controllers contain three relays designed for connection to AC MAINS circuits (i.e., voltages greater than 30V-RMS, 42.2V-PEAK or 60 V dc). Refer to [Figure 16](#) for connection information. The relay wiring compartment is not designed for voltage connections below these levels. Relays must not be powered from the same wiring used to power the controller.

24 VDC Powered sc100

The 24 VDC sc100 controller contains three relays designed for connection to LOW voltage circuits (i.e., voltages less than 30V-RMS, 42.2V-PEAK or 60 V dc). Refer to [Figure 16](#) for connection information. The wiring compartment is not designed for voltage connections above these levels. Relay must not be powered from the same wiring used to power the controller.

Figure 16 Alarm and Relay Connections

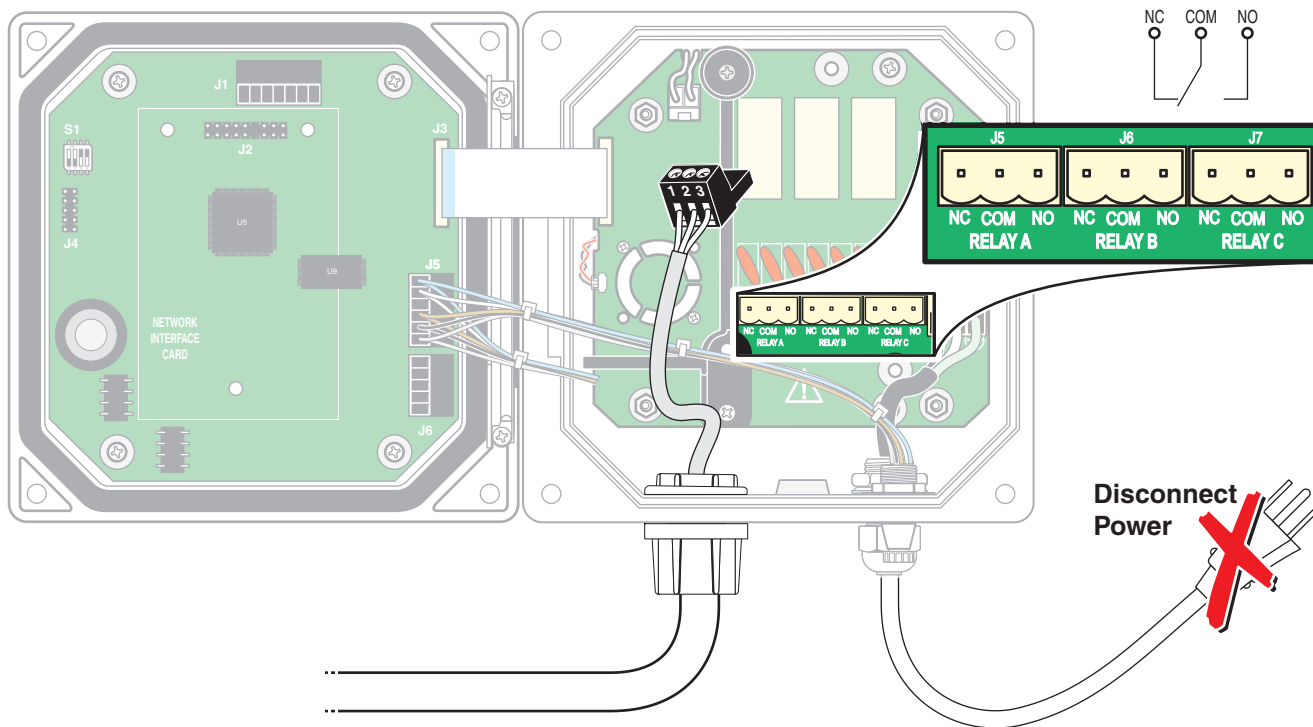

3.4.2  Connecting the Analog Outputs

DANGER

Explosion hazard. Do not connect or disconnect electrical components or circuits to the equipment unless power has been switched off or the area is known to be non-hazardous.

DANGER

For Class 1, Division 2 Hazardous Location installations, refer to the Control Drawing (Figure 2 on page 8) for permanent connection requirements for the analog output.

Two isolated analog outputs (1 and 2) are provided, see Figure 17. Each output can be set to 0–20 or 4–20 mA, and can be assigned to represent the measured parameter or secondary measurement such as temperature. Make connections with twisted-pair shielded wire and connect the shield at the controlled component end or at the control loop end. **Do not connect the shield at both ends of the cable.** Use of non-shielded cable may result in radio frequency emission or susceptibility levels higher than allowed. Maximum loop resistance is 500 ohm. Refer to the sensor manual for output software setup.

Make wiring connections at the analyzer end as shown in Table 4 and Figure 17.

Table 4 Output Connections at Terminal Block J6

Recorder Wires	Circuit Board Position
Output 2 +	1
Output 2 -	2
Shield	3
Output 1 +	4
Output 1 -	5

Figure 17 Analog Output Connections

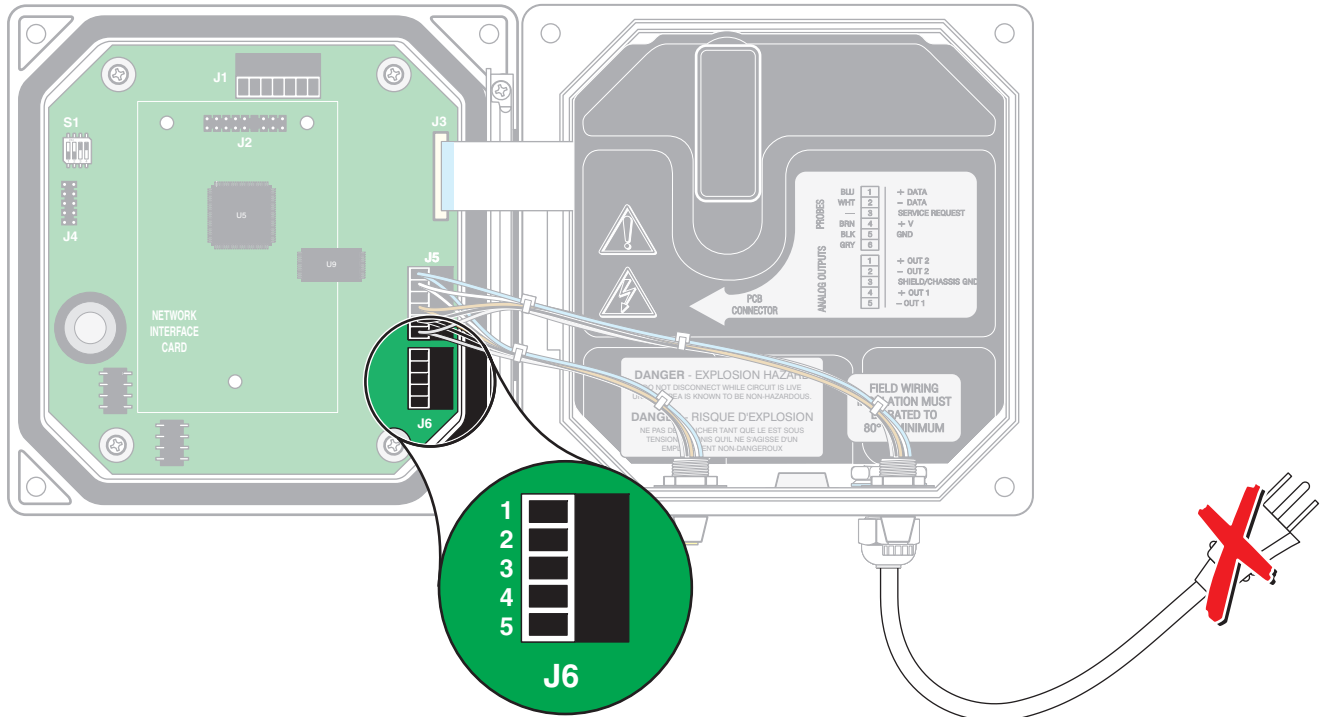

3.5 Connecting/Wiring the sc Sensor

DANGER

For Class 1, Division 2 Hazardous Location installations, refer to the Control Drawing (Figure 2 on page 8) for sensor and optional equipment connection requirements.

3.5.1 Connecting the sc Sensor in a Non-hazardous Location

3.5.1.1 Attaching a sc Sensor with a Quick-connect Fitting

The sensor cable is supplied with a keyed quick-connect fitting for easy attachment to the controller, see Figure 18. Retain the connector cap to seal the connector opening in case the sensor must be removed. Optional extension cables may be purchased to extend the sensor cable length. If the total cable length exceeds 100 m (300 ft), a termination box must be installed. When used with the termination box, the maximum cable length is 1000 m (3000 ft). See the Replacement Parts section in the sensor manual for part number information.

Figure 18 Attaching the Sensor using the Quick-connect Fitting

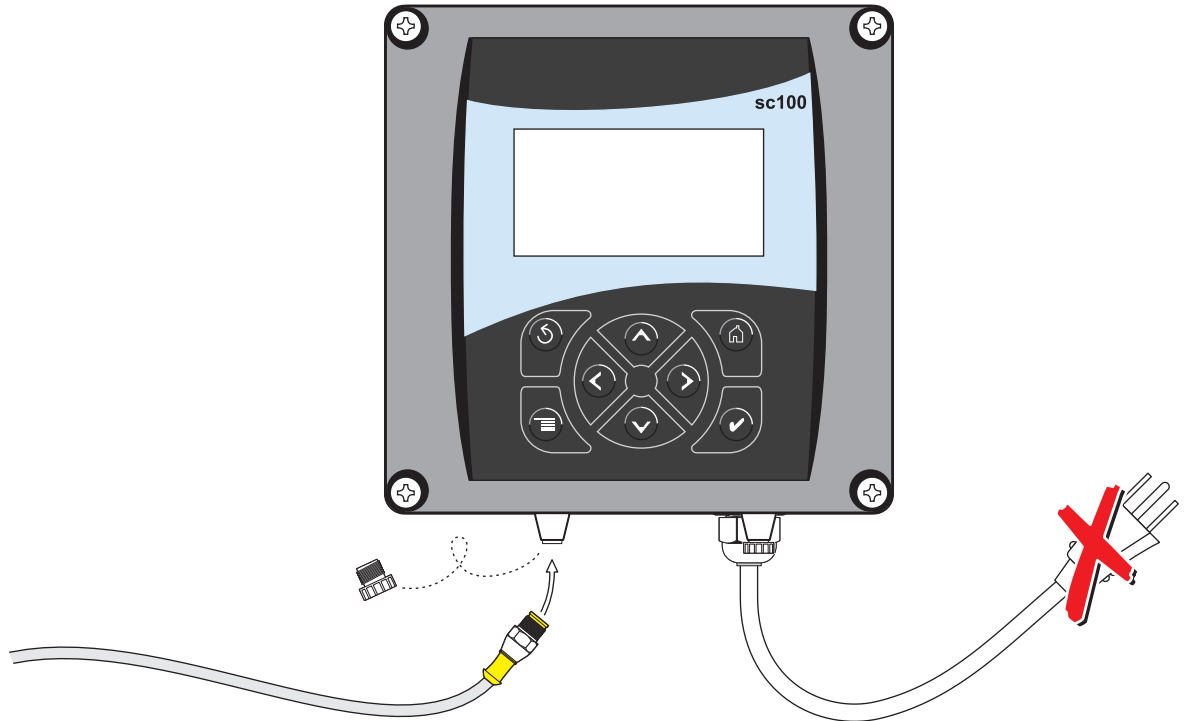

3.5.1.2 Hard-wiring a sc Sensor to the Controller

1. Open the controller cover.
2. Disconnect and remove the existing wires between the quick connect and terminal block J5, see [Figure 19](#).
3. Remove the quick connect fitting and wires and install the threaded plug on the opening to maintain the environmental rating.
4. Strip the insulation on the cable back 1-inch. Strip ¼-inch of each individual wire end.
5. Pass the cable through conduit and a conduit hub or a strain relief fitting and an available access hole in the controller enclosure. Tighten the fitting.
6. Wire as shown in [Table 5](#).
7. Close and secure the cover.

Figure 19 Hard-wiring the sensor

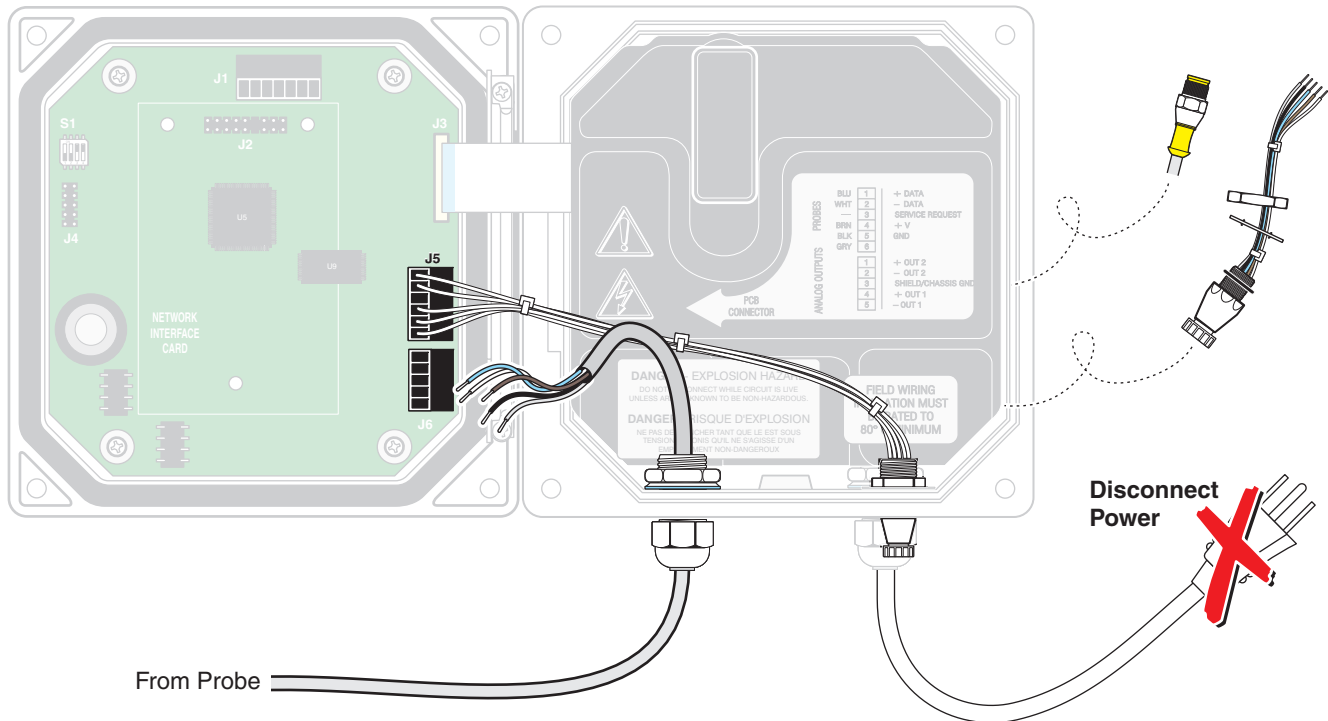

Table 5 Wiring the Sensor at Terminal Block J5

Terminal Number	Terminal Designation	Wire Color
1	Data (+)	Blue
2	Data (-)	White
3	Service Request	No Connection
4	+12 V dc	Brown
5	Circuit Common	Black
6	Shield	Shield (grey wire in existing quick disconnect fitting)

3.5.2 Connecting the sc Sensor to a Controller in a Hazardous Location

DANGER

For Class 1, Division 2 Hazardous Location installations, refer to the Control Drawing (Figure 2 on page 8) for sensor and optional equipment connection requirements.

DANGER

Explosion hazard. Do not connect or disconnect electrical components or circuits to the equipment unless power has been switched off or the area is known to be non-hazardous.

3.5.2.1 Attaching a sc Sensor with a Quick-connect Fitting in a Hazardous Location

The sensor cable is supplied with a keyed quick-connect fitting for easy attachment to the controller, see Figure 18. For hazardous locations, a connector safety lock **must** be installed. Retain the connector cap to seal the connector opening in case the sensor must

be removed. Optional extension cables may be purchased to extend the sensor cable length (up to a maximum length of 1000 m (3000 ft)).

1. Remove the connector cap from sc100 controller. Retain the connector cap to seal the connector opening in case the sensor must be removed.
2. Connect the sensor connector to the plug on the sc100.
3. Install a connector safety lock (Figure 20). Align the lock over the connector and squeeze the two halves together to lock. To remove the connector safety lock by inserting a small flat-bladed screwdriver into the locking groove. Pivot the screwdriver away from the groove and separate the two halves (Figure 20).

Figure 20 Installing the Connector Safety Lock

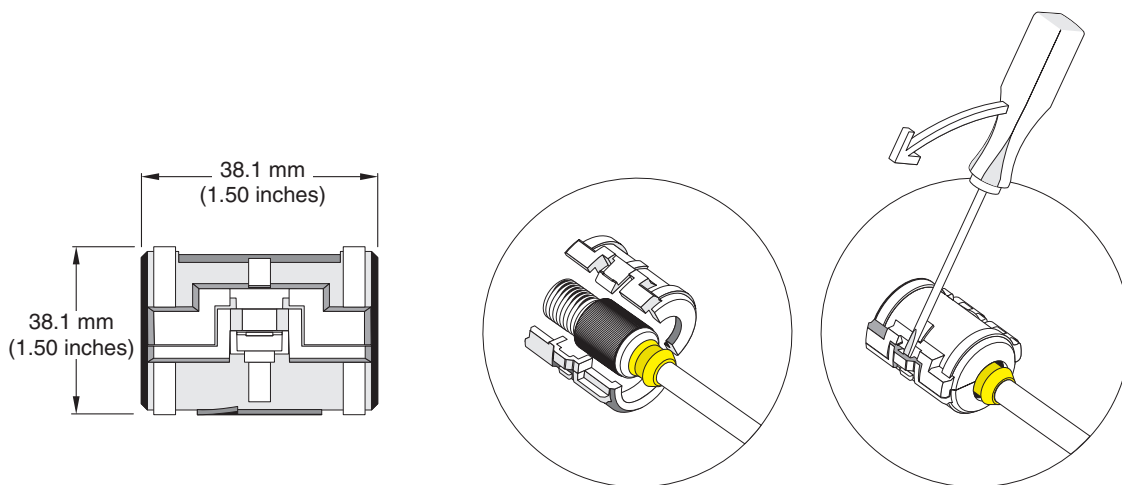

3.6 Wiring the Digital Gateway

DANGER

For Class 1, Division 2 Hazardous Location installations, refer to the Control Drawing (Figure 2 on page 8) for sensor and optional equipment connection requirements.

The digital gateway is designed to provide a digital interface to the sc100 controller (or other appropriate digital controller). The non-sensor end is connected to the controller as described in [section 3.5.1 on page 20](#) for non-hazardous locations and [section 3.5.2 on page 22](#) for hazardous locations.

3.7 Connecting the Optional Digital Output

DANGER

Explosion hazard. Do not connect or disconnect electrical components or circuits to the equipment unless power has been switched off or the area is known to be non-hazardous.

DANGER

For Class 1, Division 2 Hazardous Location installations refer to the Control Drawing (Figure 2 on page 8) for permanent connection requirements for the Digital Outputs. Installation of communication protocols other than those specified in the Control Drawing are not allowed for Class 1, Division 2 Hazardous Locations.

At this time, the manufacturer supports Modbus RS485, Modbus RS232, and Profibus DP communication protocols. The optional digital output card is installed in the location indicated in [Figure 22 on page 25](#). Terminal block J1 provides user connection to the optional network card. The terminal connection is based on the selected network card. Refer to the instructions supplied with the network card for more details.

Note: The sc100/1720E system also supports the AquaTrend Network.

Surge Protection Recommendation for Profibus DP

Many industrial environments are vulnerable to power transients and lightning. Water and wastewater plants are frequent targets of lightning. Lightning generated fields and power surges can cause instrument failures at these facilities. Surge protectors limit the magnitude of over-voltage transients and protect equipment from damage. To be effective on Data lines, at a minimum, a surge protector should provide two stages of protection with sub-nanosecond response time. Data line surge protection should be installed on a Profibus DP network where it might be susceptible to lightning or transients. The purpose of the surge protector is to protect the equipment that it is located next to, not the network cable.

For the best performance/protection connect the surge protector as close as possible to the device to be protected and connect the device (instrument) ground connection through the surge protector's ground to the local protective earth ground. Contact your local Profibus network component supplier for their recommendation as to which surge protectors may be best for your system.

Table 6 Digital Output Terminal Assignments

Terminal Number	AquaTrend Network ¹	Modbus RS485 2-wire	Modbus RS485 4-wire	Modbus RS232	Profibus DP
1	Network A	D+	RD+	Rx	A1- (out)
2	Network B	D-	RD-	No connection	B1+ (out)
3	Network A	No connection	TD+	Tx	A2- (in)
4	Network B	No connection	TD-	No connection	B2+ (in)
5	No connection	Common	Common	Common	Common
6	No connection	No connection	No connection	No connection	No connection
7	Shield	Shield	Shield	Shield	Shield

¹ The AquaTrend Network only applies to sc100/1720E systems

Figure 21 RS232 Connection to Customer-supplied Computer 9-pin D Subminiature Connector

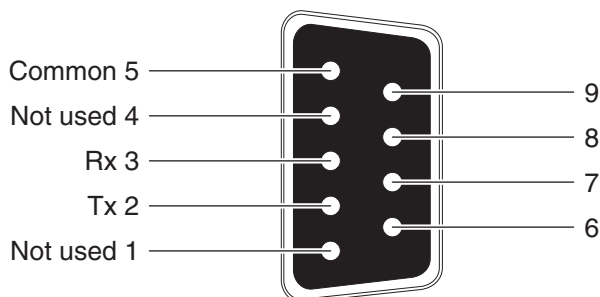
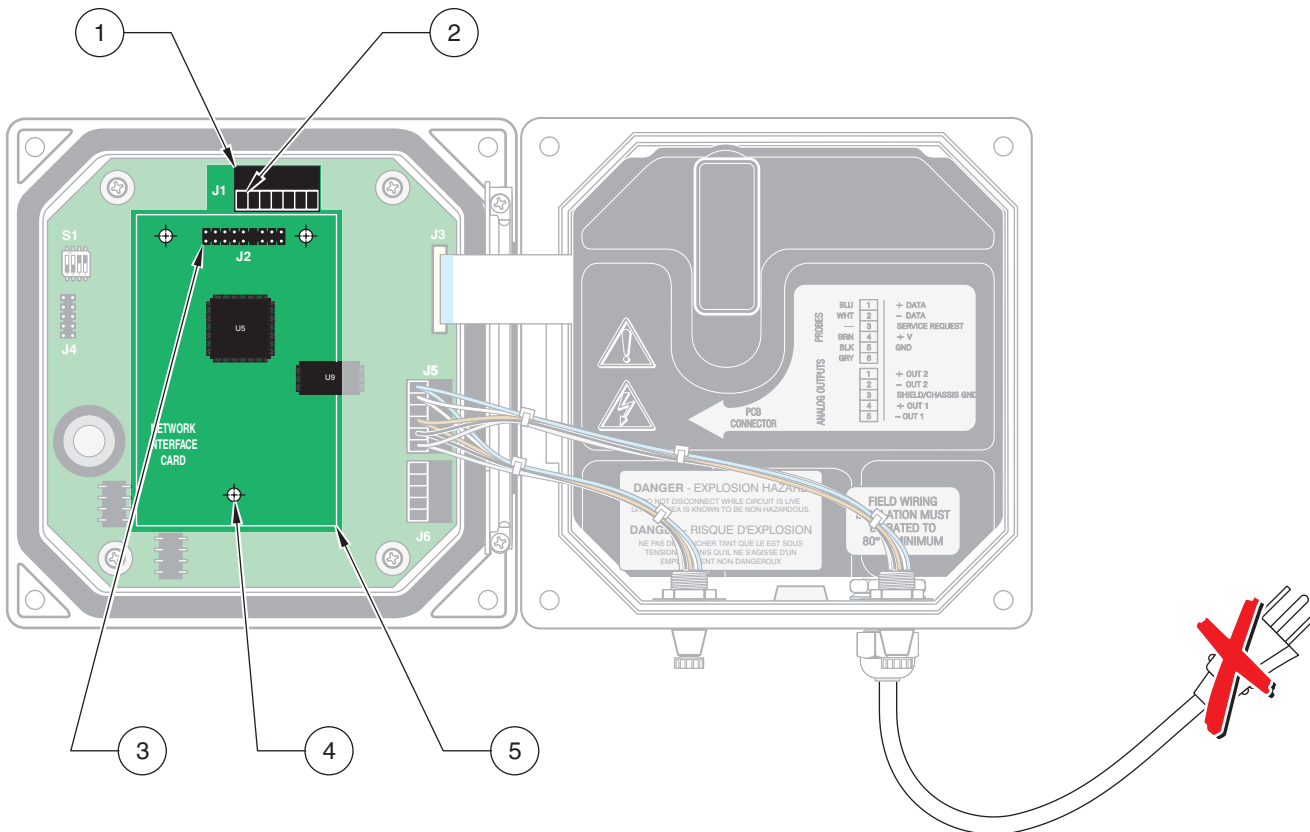

Figure 22 Network Card Position in the Controller



1. J2—Network card header	4. Mounting hole (3)
2. J2 Pin 1	5. Network card placement
3. J1 Terminal	

Section 4 Operation

4.1 Using the Keypad



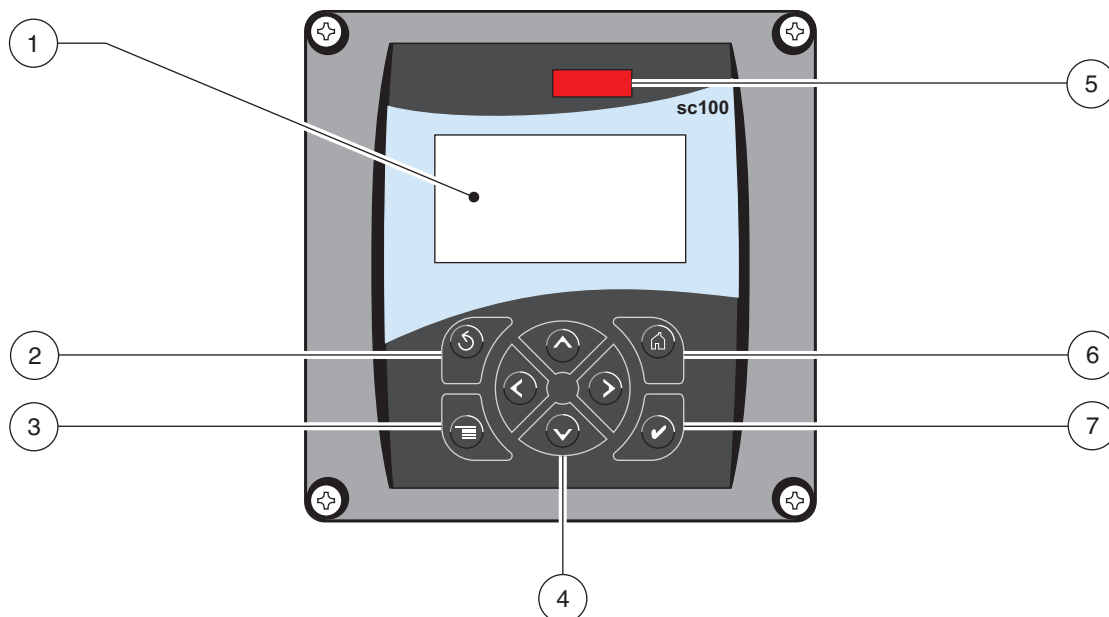

The front of the controller is shown in [Figure 23](#). The keypad consists of the eight keys described in [Table 7](#).

Figure 23 Front of the Controller



1. Instrument display	5. IrDA Port
2. BACK key	6. HOME key
3. MENU key	7. ENTER key
4. RIGHT, LEFT, UP, and DOWN keys	

Table 7 Controller Key Functions/Features

Number	Key	Function
2		Moves back one level in the menu structure.
3		Moves to the main menu from other menus. This key is not active in menus where a selection or other input must be made.
4		Navigates through the menus, changes settings, and increments and decrements digits.
6		Moves to the Main Measurement screen from any other screen. This key is not active in menus where a selection or other input must be made.
7		Accepts an input value, updates, or accepts displayed menu options.

4.2 Controller Display Features

When a sensor is connected and the controller is in measurement mode, the controller automatically identifies the connected sensors and displays associated measurements.

The display will flash on startup, when a sensor error has occurred, when the hold outputs function has been activated, and when a sensor is being calibrated. An active system warning will cause the warning icon (a triangle with an exclamation point inside) to be displayed on the right side of the display. See [Figure 24](#).

Figure 24 Display Example

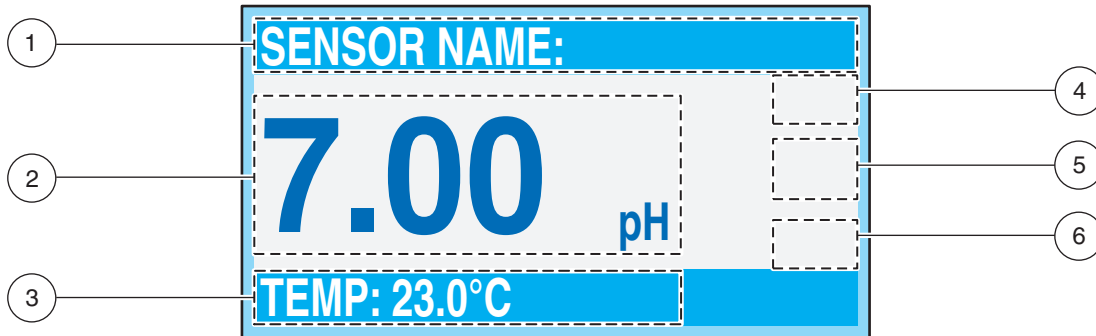

1. Status bar. Indicates the sensor name and status of relays. The relay letter is displayed when the relay is energized.	4. Parameter
2. Main measurement	5. Warning icon area
3. Secondary measurement (if applicable)	6. Measurement units

4.2.1 Important Key Presses

- Press **HOME** then **RIGHT** or **LEFT** to display two readings when two sensors are connected. Continue to press **RIGHT** or **LEFT** to toggle through the available display options:

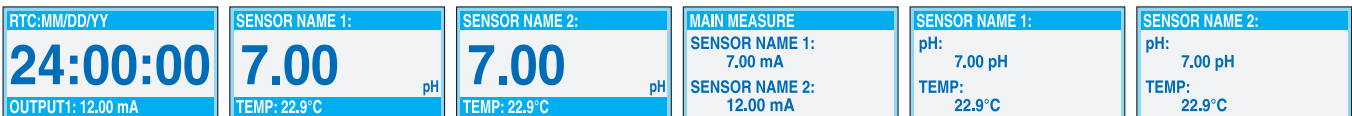

- Press **UP** and **DOWN** to toggle the status bar at the bottom of the measurement display to display the secondary measurement (temperature) and output information.



- When in Menu mode, an arrow may appear on the right side of the display to indicate that more menus are available. Press **UP** or **DOWN** (corresponding to the arrow direction) to display additional menus.

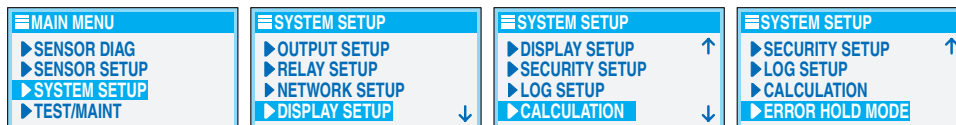











4.2.2 Software Text Abbreviations













Abbreviation	Meaning	Abbreviation	Meaning
Adj	Adjust	P/F	Pass/Fail
Cal	Calibration	Pass	Password
Cont	Continue	Preped	Prepared
Dflt	Default	SN	Serial Number
Diag	Diagnostic	Std	Standard
Freq	Frequency	Temp	Temperature
Int	Internal	Vers	Version
Meas	Measurement	Xfer	Transfer

4.3 System Setup

4.3.1 Adjusting Display Contrast

















Step	Select	Menu Level/Instructions	Confirm
1		MAIN MENU	—
2		SYSTEM SETUP	
3		DISPLAY SETUP	
4	—	ADJUST CONTRAST	
5	 	(+0–50)	
6	 	Main Menu or Main Measurement Screen	—

4.3.2 Specifying the Displayed Language





















Step	Select	Menu Level/Instructions	Confirm
1		MAIN MENU	—
2		SYSTEM SETUP	
3		DISPLAY SETUP	
4		LANGUAGE	
5	 	Select the language from displayed options.	
6	 	Main Menu or Main Measurement Screen	—

4.3.3 Setting the Time and Date

4.3.3.1 Setting the Time (24-hr format)

Step	Select	Menu Level/Instructions	Confirm
1		MAIN MENU	—
2		SYSTEM SETUP	
3		DISPLAY SETUP	
4		SET DATE/TIME	
5		Highlight TIME	
6	 	Select the character to edit.	
	 	Scroll to appropriate number.	
7	 	Main Menu or Main Measurement Screen	—

4.3.3.2 Setting the Date Format and Date

Step	Select	Menu Level/Instructions	Confirm
1		MAIN MENU	—
2		SYSTEM SETUP	
3		DISPLAY SETUP	
4		SET DATE/TIME	
5	—	Highlight DATE FORMAT	
6	 	Choose the appropriate date format from the displayed options.	
7		Highlight DATE	
8	 	Select the character to edit.	
	 	Scroll to the appropriate number.	
9	 	Main Menu or Main Measurement Screen	—











4.4 Setting up System Security

The passcode feature of the sc100 restricts unauthorized access to configuration and calibration settings. The passcode is factory set to **sc100** (the five digits must be followed by a space to remove the trailing asterisk). The following two options are available:

















Disabled: All configuration settings and calibrations can be changed. This is the default.

Enabled: Certain calibration and Test/Maint settings/operations cannot be accessed without the passcode. If the passcode is enabled, it may be edited ([section 4.4.2](#)). The passcode can include up to six digits (alpha and/or numeric and available characters). If the instrument is reset using the Configure/Default Setup menu selection, the passcode will return to the factory default. If a passcode is forgotten, obtain the Master passcode from the Technical Consulting Services Department, see [Section 9 on page 46](#).

4.4.1 Setting the Passcode

Step	Select	Menu Level/Instructions	Confirm
1		MAIN MENU	—
2		SYSTEM SETUP	
3		SECURITY SETUP	
4	—	SET PASSCODE	
5		Highlight ENABLE	
6	 	Main Menu or Main Measurement Screen	—













4.4.2 Editing the Passcode

Step	Select	Menu Level/Instructions	Confirm
1		MAIN MENU	—
2		SYSTEM SETUP	
3		Highlight SECURITY SETUP	
4		ENTER PASSCODE	
5		EDIT PASSCODE	
6	 	EDIT PASSCODE select character (shown in brackets)	—
	 	EDIT PASSCODE move to the next character	
7	 	Main Menu or Main Measurement Screen	—

4.5 Output Options

Refer to the [System Setup on page 29](#) for more information on the output options menu. The analyzer provides two isolated analog outputs (Output 1 and Output 2).



















4.5.1 Navigating to the Output Options Menu

Step	Select	Menu Level/Instructions	Confirm
1		MAIN MENU	—
2		SYSTEM SETUP	
3		OUTPUT SETUP	
4		SELECT OUTPUT	
5	 	Customize the options, refer to System Setup on page 29 .	
6	 	Main Menu or Main Measurement Screen when Output options are configured.	—

4.5.2 Hold/Transfer Outputs











During normal measurement operation, the analog outputs can be held at the last measured value or transferred to a preset value.

4.5.2.1 Hold/Transfer Outputs until Release

Step	Select	Menu Level/Instructions	Confirm
1		MAIN MENU	—
2		TEST/MAINT	
3		HOLD OUTPUTS	
4		SET OUTMODE	
5		Select HOLD OUTPUTS or XFER OUTPUTS	
6		SET CHANNELS	
7	 	Select ALL or one of the connected sensors.	—
8		ACTIVATION	
9		Select LAUNCH	
10	 	Main Menu or Main Measurement Screen	reading will flash

During calibration, analog outputs can remain active, held, or transferred to a preset mA value.













4.5.3 Release Outputs

Step	Select	Menu Level	Confirm
1		MAIN MENU	—
2		TEST/MAINT	
3		HOLD OUTPUTS	
4		ACTIVATION	
5		RELEASE	
6	 	Main Menu or Main Measurement Screen	—

4.6 Relay Options

Refer to [System Setup on page 29](#) for more information on the relay options menu.

4.6.1 Navigating to the Relay Options Menu

Step	Select	Menu Level/Instructions	Confirm
1		MAIN MENU	—
2		SYSTEM SETUP	
3		RELAY SETUP	
4		SELECT RELAY	
5	 	Customize the options, refer to System Setup on page 29 .	
6	 	Main Menu or Main Measurement Screen when Relay options are configured.	—

4.7 Data Event Logging Options

The sc100 provides three data logs (one for each sensor and one for calculated values) and three event logs (one for each sensor and one for the controller). The data logs store the measurement data at selected intervals. The event log stores a variety of events that occur on the devices such as configuration changes, alarms, and warning conditions. The data logs are stored in a packed binary format and the event logs are stored in a CSV format. The logs can be downloaded through the digital network port, the IrDA port, or through the service port using the service cable LZx887.

4.8 Digital Network Options

The sc100 provides two digital communication methods with the controller (the digital network port and the IrDA port). Either of the digital ports can be used to access setup data, measurement data, or data/event logs. For the features available for each individual digital network port, refer to the instruction sheet supplied with the selected network card.

4.9 System Setup Menu

OUTPUT SETUP (see section 4.5.1 on page 32 for expanded menu information)
SELECT OUTPUT 1 OR 2
SELECT SOURCE
Press ENTER to access a list of all connected sensors and select the sensor that will drive the output.
SET PARAMETER
Press ENTER to select from the displayed parameters. Highlight the appropriate displayed parameter and press ENTER .
SET FUNCTION
Select LINEAR CONTROL for current output to track the measurement valve. Select PID CONTROL for the sc100 to operate as a PID controller.
SET TRANSFER
Each analog output is normally active, responding to the measured value of its assigned parameter. However, during calibration, each output can be transferred to this preset transfer value.
SET FILTER
Average measurements over time (0–999 seconds). Default is 0 seconds. The higher the value, the longer the sensor signal response time will be to a change in the actual process value.
SCALE 0 mA/4 mA
Select 0 mA or 4 mA for minimum current (outputs will be set to 0–20 mA or 4–20 mA).
ACTIVATE
Dependent on Function selected previously. See section 4.5.1 on page 32 for additional information.
FUNCTION set to LINEAR CONTROL
If LINEAR CONTROL was selected in SET FUNCTION , set the low and the high values for the current output here.
FUNCTION set to PID CONTROL
<ol style="list-style-type: none"> 1. SET MODE: AUTO or MANUAL 2. PHASE: DIRECT or REVERSE controller operation. 3. SET SETPOINT: enter the setpoint the PID control will control the process to. 4. PROP BAND: control the proportional band for the PID control. 5. INTEGRAL: control the integral action time period in minutes. 6. DERIVATIVE: control the settings for the rate control.

4.9 System Setup Menu (continued)

RELAY SETUP
Select Relay A, B, or C
SELECT SOURCE
Select from none, a connected sensor, or the real time clock (RTC)
SET PARAMETER
Press ENTER to select from the displayed parameters.
SET FUNCTION
Source set to sensor
Alarm: Operates relays in response to the measured parameter. Contains separate High and Low Alarm points, deadbands, and ON/OFF delay.
Feeder Control: Operates in response to the measured parameter. Can be set for phasing, setpoint, deadband, overfeed timer, and ON/OFF delay.
Event Control: Controls a cleaning system (or equivalent) on a timed basis.
Warning: Activated when the analyzer detects a sensor warning.
PMW Control: Allows the relay to provide a duty cycled output.
Freq Control: Allows the relay to cycle at a frequency between the minimum pulse per minute and maximum pulse per minute.
Source set to RTC
Timer: Sets the timer for a cleaning system (or equivalent). Controls the output hold, interval, duration, and off delay.
SET TRANSFER
Sets the relay to Energize or De-energize (user-selectable). Normally, each control or alarm relay is active, responding to the measured value of its assigned parameter. During calibration, however, the relay can be transferred to a preset on/off state to suit the application requirements. Select Energize or De-energize and press ENTER .
FAILSAFE
Allows the user to create a state where the normal condition is energized. The relay is de-energized when an error condition is experienced. Select YES (Energized) or NO (De-energized) and press ENTER . YES sets the relay normal condition to energized resulting in the relay becoming de-energized when an error condition is experienced.
ACTIVATION
Function set to ALARM
LOW ALARM —Sets the value where the relay will turn on in response to decreasing measured value. For example, if the low alarm is set for 1.0 and the measured value drops to 0.9, the relay will be activated.
HIGH ALARM —Sets the value where the relay will turn on in response to increasing measured value. For example, if the high alarm is set for 1.0 and the measured value increases to 1.1, the relay will be activated.
LOW DEADBAND —Sets the range where the relay remains on after the measured value increases above the low alarm value. Default is 5% of the range. For example, if the low alarm is set for 1.0 and the low deadband is set for 0.5, then the relay remains on between 1.0 and 1.5.
HIGH DEADBAND —Sets the range where the relay remains on after the measured value decreases below the high alarm value. Default is 5% of the range. For example, if the high alarm is set for 4.0 and the high deadband is set for 0.5, then the relay remains on between 3.5 and 4.0.
OFF DELAY —Sets a time (0–300 seconds) to delay the relay from normally turning off.
ON DELAY —Sets a time (0–300 seconds) to delay the relay from normally turning on.
LOW ALARM —Sets the value where the relay will turn on in response to decreasing measured value. For example, if the low alarm is set for 1.0 and the measured value drops to 0.9, the relay will be activated.

4.9 System Setup Menu (continued)

Function set to FEEDER CONTROL
PHASE—"High" phase assigns the relay setpoint to respond to an increasing measured value; conversely, a "Low" phase assigns the relay setpoint to respond to a decreasing measured value.
SET SETPOINT—Sets the value where the relay will turn on.
DEADBAND—Sets the range where the relay remains on after the measured value decreases below the setpoint value (high phase relay) or increases above the setpoint value (low phase relay).
OVERFEED TIMER—Sets the time (0–999.9 minutes) to limit how long the relay can remain on.
OFF DELAY—Sets a time (0–999 seconds) to delay the relay from normally turning off.
ON DELAY—Sets a time (0–999 seconds) to delay the relay from normally turning on.
Function set to EVENT CONTROL
SET SETPOINT—Sets the value where the relay will turn on.
DEADBAND—Sets the range where the relay remains on after the measured value decreases below the setpoint value (high phase relay) or increases above the setpoint value (low phase relay).
OnMax TIMER—Sets the time (0–999 minutes) to limit the time the relay can remain on.
OffMax TIMER—Sets a time (0–999 minutes) to delay the relay from normally turning off.
OnMin TIMER—Sets the time (0–999 minutes) to limit the time the relay can remain on.
OffMin TIMER—Sets the time (0–999 minutes) to limit the time the relay can remain off.
Function set to TIMER (RTC selected in SELECT SOURCE)
HOLD OUTPUTS—Set OUTMODE to select output hold operation and select channels that cause the outputs to be held.
INTERVAL—Set the off time for the relay.
DURATION—Set the on time for the relay.
OFF DELAY—Set the time for additional hold/output time after the relay has been turned off.
Function set to WARNING CONTROL
WARNING LEVEL—Set the warning level that will trigger a relay. Range: 0–32. For example: If warnings 1–9 are active on the instrument, set the warning level to 0 to allow all warnings to trigger the relay; set the warning level to 5 to allow warnings 6 and above to trigger the relay. Set the warning level to 9 or greater to not trigger the relay on any warning.
Function set to PMW CONTROL
SET MODE—Auto or Manual
PHASE—Direct or Reverse
SET SETPOINT—Control Setpoint
DEAD ZONE—Zone around setpoint where output is off
PERIOD—3–60 second PMW period
MIN WIDTH—Minimum pulse width in 0.1 seconds
MAX WIDTH—Maximum pulse width in 0.1 seconds
PROP BAND—Proportional control band
INTEGRAL—Integral control setting (minutes)
Function set to FREQ CONTROL
SET MODE—Auto or Manual
PHASE—Direct or Reverse
SET SETPOINT—Control Setpoint
DEAD ZONE—Zone around setpoint where output is off
MIN WIDTH—0.001–200 pulses per minute
MAX WIDTH—0.001–200 pulses per minute
PROP BAND—Proportional control band (this is outside of the dead zone)
INTEGRAL—Integral control setting (minutes)

4.9 System Setup Menu (continued)

NETWORK SETUP (this menu appears only if a network card is installed in the controller)	
SET MODE	Auto or Manual
MODBUS ADDRESS	Highlight sc100 Analyzer, or either connected sensor then press ENTER . Choose a number between 1 and 247 as the address (each source must have a different address) then press ENTER .
BAUD RATE	Select a baud rate of 9600, 19200, 38.4K, 57.6K, or 115.2K. Default: 19200
STOP BITS	Select 1 or 2 stop bits. Default: 1
MODBUS MODE	Select RTU or ASCII. Default: RTU
DATA ORDER	Select Normal or Swapped. Default: Swapped
DISPLAY SETUP	
ADJUST CONTRAST	Use the UP and DOWN keys to increase or decrease the contrast, see section 4.3.1 on page 29 .
LANGUAGE	The default is English. Choose Spanish, German, or French to allow all menus to appear in the selected language.
SET DATE/TIME	Select the date format and to set the date and time (24-hour (military) format), see section 4.3.3 on page 30 .
SECURITY SETUP (Enter a 6-digit passcode)	
SET PASSCODE	
DIISABLE	Disables system security. See section 4.4 on page 31 .
ENABLE	Enables system security. See section 4.4 on page 31 .
LOG SETUP	
DATALOG SETUP	Setup datalogging of displayed sensor measurements
CALCULATION	
SET VARIABLE X	Select the sensor corresponding to the variable set as "X".
SET VARIABLE Y	Select the sensor corresponding to the variable set as "Y".
SET PARAMETER	Select the parameter to be associated with the variable.
SET FORMULA	Select the formula of the calculation to be performed on "X" and "Y".

4.9 System Setup Menu (continued)

ERROR HOLD MODE
HOLD OUTPUTS
Holds outputs when unable to communicate with the sensor.
XFER OUTPUTS
Goes to transfer state when unable to communicate with the sensor.

4.10 Test/Maint Menu

STATUS
Indicates the status of each relay and indicates which sensors are connected to the controller.
OUTPUT CAL
SELECT OUTPUT 1 OR 2
Calibrate Analog Output by specifying values to correspond to 4 mA and 20 mA using the UP and DOWN arrow keys.
HOLD OUTPUTS
SET OUTMODE
Choose Hold Outputs or Xfer Outputs
SET CHANNELS
Choose any individual attached sensor or all attached sensors to be held or transferred.
ACTIVATION
Select Launch or Release.
OVERFEED RESET
Reset the overfeed time out.
TEST OUTPUT
SELECT OUTPUT 1 OR 2
Set the analog output to a desired current level. Range: 0–20
TEST RELAY
SELECT RELAY A, B, OR C
Energize or de-energize the selected relay.
RESET CONFIG
Reset to default configuration
SIMULATION
SELECT SOURCE, SET PARAMETER, SET SIM VALUE
Simulate sensor measurement value for testing the outputs and relays.
SCAN SENSORS
Manually scans for sensors to determine if sensors have been added or removed.
MODBUS STATS
Indicates the communication statistics for use with an external network.
CODE VERSION
Indicates the controller software version.

DANGER

Only qualified personnel should conduct the tasks described in this section of the manual.



DANGER

Explosion hazard. Do not connect or disconnect equipment unless power has been switched off or the area is known to be non-hazardous.

DANGER

Explosion hazard. Substitution of components may impair suitability for Class 1, Division 2.

5.1 Cleaning the Controller

With the enclosure securely closed, wipe the exterior with a damp cloth.

5.2



Fuse Replacement

The instrument contains two mains fuses. Failed fuses are an indication that an equipment problem could exist. Problem resolution and fuse replacement should be performed only by qualified service personnel. Refer to [Figure 25](#) and the following steps to replace the fuses:

1. Disconnect power to the controller (including power to relays and other components, if powered).
2. Open the hinged controller cover by completely loosening all four captive screws in the cover.
3. Remove the high voltage barrier; pull out on the lever of the captive fastener then pull straight out on the barrier. Set the barrier aside for reinstallation.
4. Remove the fuses and install new fuses of the same type and rating:
 - ac Powered sc100: T, 1.6 A, 250 V, slow blow
 - 24 V dc powered sc100: T, 3 A, 250V, slow blow
5. Reinstall the high voltage barrier.
6. Close the controller cover and hand-tighten the four screws.
7. Reconnect power to the instrument.

Figure 25 Fuse Replacement

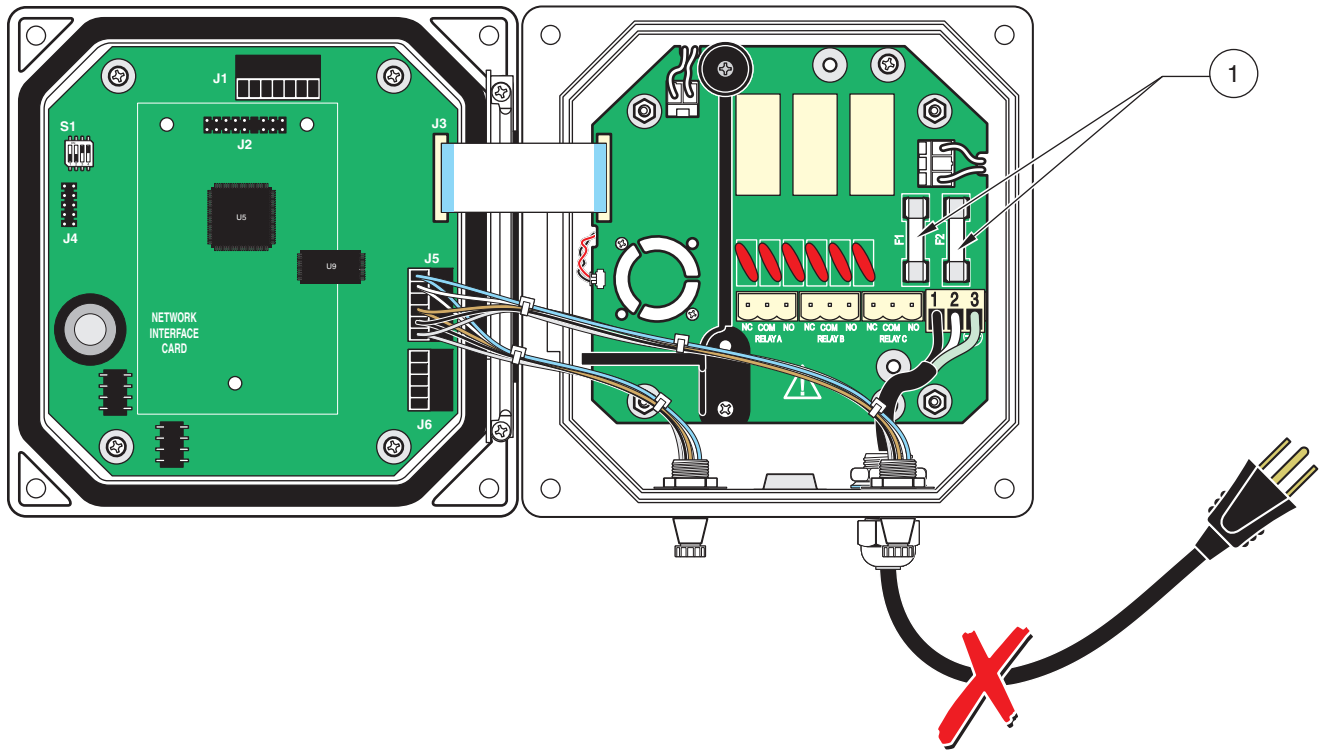

1. Fuses F1 and F2.
AC powered, T, 1.6A, 250V, slow blow
DC powered, T, 3A, 250V, slow blow

Section 6 Replacement Parts and Accessories

6.1 Replacement Items

Description	Quantity	Catalog Number
Controller Installation Kit	each	58672-00
Fuse, T, 3A, 250V, slow blow	each	41060
Fuse, T, 1.6 A, 250 V, slow blow	each	52083-00
Instruction manual, English	each	58600-18

6.2 Accessories

Description	Quantity	Catalog Number
Digital output card for Modbus RS232 communication	each	59200-00
Digital output card for Modbus RS485 communication	each	59200-01
Locknut	each	1059612
Plug, conduit opening	each	58687-00
Power cord with strain relief, 115 V	each	54488-00
Power cord with strain relief, 230 V	each	54489-00
Sealing Washer	each	1033814
Strain relief, Heyco	each	4379400
Sun Shield	each	58690-00

Section 7 Compliance Information

Hach Co. certifies this instrument was tested thoroughly, inspected, and found to meet its published specifications when it was shipped from the factory.

The **Model sc100** has been tested and is certified as indicated to the following instrumentation standards:

Product Safety

FM 3600/3611 Class I, Division 2 (ETL Listing I.D. # 65454)
UL 61010A-1 (ETL Listing # 65454)
CSA C22.2 No. 1010.1 & No. 213-M1987 Class I, Division 2 (ETLc Certification I.D. # 65454)
Certified by Hach Co. to EN 61010-1 Amds. 1 & 2 (IEC1010-1) per 73/23/EEC, supporting test records by Intertek Testing Services.

Immunity

This equipment was tested for Industrial level EMC per:

EN 61326 (EMC Requirements for Electrical Equipment for Measurement, Control and Laboratory Use) **per 89/336/EEC EMC:** Supporting test records by Hach Company, certified compliance by Hach Company.

Standards include:

IEC 1000-4-2:1995 (EN 61000-4-2:1995) Electrostatic Discharge Immunity (Criteria B)
IEC 1000-4-3:1995 (EN 61000-4-3:1996) Radiated RF Electromagnetic Field Immunity (Criteria A)
IEC 1000-4-4:1995 (EN 61000-4-4:1995) Electrical Fast Transients/Burst (Criteria B)
IEC 1000-4-5:1995 (EN 61000-4-5:1995) Surge (Criteria B)
IEC 1000-4-6:1996 (EN 61000-4-6:1996) Conducted Disturbances Induced by RF Fields (Criteria A)
IEC 1000-4-11:1994 (EN 61000-4-11:1994) Voltage Dip/Short Interruptions (Criteria B)

Additional Immunity Standard/s include:

ENV 50204:1996 Radiated Electromagnetic Field from Digital Telephones (Criteria A)

Emissions

This equipment was tested for Radio Frequency Emissions as follows:

Per **89/336/EEC EMC: EN 61326:1998** (Electrical Equipment for measurement, control and laboratory use—EMC requirements) Class “A” emission limits. Supporting test records by Hewlett Packard, Fort Collins, Colorado Hardware Test Center (A2LA # 0905-01) and certified compliance by Hach Company.

Standards include:

EN 61000-3-2 Harmonic Disturbances Caused by Electrical Equipment
EN 61000-3-3 Voltage Fluctuation (Flicker) Disturbances Caused by Electrical Equipment

Additional Emissions Standard/s include:

EN 55011 (CISPR 11), Class “A” emission limits

Canadian Interference-causing Equipment Regulation, IECS-003, Class A

Supporting test records by Hewlett Packard, Fort Collins, Colorado Hardware Test Center (A2LA # 0905-01) and certified compliance by Hach Company.

This Class A digital apparatus meets all requirements of the Canadian Interference-causing Equipment Regulations.

Cet appareil numérique de la classe A respecte toutes les exigences du Règlement sur le matériel brouilleur du Canada.

FCC PART 15, Class “A” Limits

Supporting test records by Hewlett Packard, Fort Collins, Colorado Hardware Test Center (A2LA # 0905-01) and certified compliance by Hach Company.

This device complies with Part 15 of the FCC Rules. Operation is subject to the following two conditions:

(1) this device may not cause harmful interference, and (2) this device must accept any interference received, including interference that may cause undesired operation.

Changes or modifications to this unit not expressly approved by the party responsible for compliance could void the user's authority to operate the equipment.

This equipment has been tested and found to comply with the limits for a Class A digital device, pursuant to Part 15 of the FCC Rules. These limits are designed to provide reasonable protection against harmful interference when the equipment is operated in a commercial environment. This equipment generates, uses, and can radiate radio frequency energy and, if not installed and used in accordance with the instruction manual, may cause harmful interference to radio communications. Operation of this equipment in a residential area is likely to cause harmful interference, in which case the user will be required to correct the interference at his own expense. The following techniques of reducing the interference problems are applied easily.

1. Disconnect the Model sc100 Controller from its power source to verify that it is or is not the source of the interference.
2. If the Model sc100 Controller is connected into the same outlet as the device with which it is interfering, try another outlet.
3. Move the Model sc100 Controller away from the device receiving the interference.
4. Reposition the receiving antenna for the device receiving the interference.
5. Try combinations of the above.

Section 8 How to Order

U.S.A. Customers

By Telephone:

6:30 a.m. to 5:00 p.m. MST
Monday through Friday
(800) 227-HACH (800-227-4224)

By Fax:

(970) 669-2932

By Mail:

Hach Company
P.O. Box 389
Loveland, Colorado 80539-0389 U.S.A.
Ordering information by e-mail: orders@hach.com

Information Required

- Hach account number (if available)
- Your name and phone number
- Purchase order number
- Brief description or model number
- Billing address
- Shipping address
- Catalog number
- Quantity

International Customers

Hach maintains a worldwide network of dealers and distributors. To locate the representative nearest you, send an e-mail to: intl@hach.com or contact:

Hach Company World Headquarters; Loveland, Colorado, U.S.A.
Telephone: (970) 669-3050; Fax: (970) 669-2932

Technical and Customer Service (U.S.A. only)

Hach Technical and Customer Service Department personnel are eager to answer questions about our products and their use. Specialists in analytical methods, they are happy to put their talents to work for you.

Call 1-800-227-4224 or e-mail techhelp@hach.com

Section 9 **Repair Service**

Authorization must be obtained from Hach Company before sending any items for repair. Please contact the Hach Service Center serving your location.

In the United States:

Hach Company
Ames Service
100 Dayton Avenue
Ames, Iowa 50010
(800) 227-4224 (U.S.A. only)
FAX: (515) 232-3835

In Canada:

Hach Sales & Service Canada Ltd.
1313 Border Street, Unit 34
Winnipeg, Manitoba
R3H 0X4
(800) 665-7635 (Canada only)
Telephone: (204) 632-5598
FAX: (204) 694-5134
E-mail: canada@hach.com

**In Latin America, the Caribbean, the Far East,
Indian Subcontinent, Africa, Europe, or the Middle East:**

Hach Company World Headquarters,
P.O. Box 389
Loveland, Colorado, 80539-0389 U.S.A.
Telephone: (970) 669-3050
FAX: (970) 669-2932
E-mail: intl@hach.com

Section 10 Limited Warranty

Hach Company warrants its products to the original purchaser against any defects that are due to faulty material or workmanship for a period of one year from date of shipment unless otherwise noted in the product manual.

In the event that a defect is discovered during the warranty period, Hach Company agrees that, at its option, it will repair or replace the defective product or refund the purchase price excluding original shipping and handling charges. Any product repaired or replaced under this warranty will be warranted only for the remainder of the original product warranty period.

This warranty does not apply to consumable products such as chemical reagents; or consumable components of a product, such as, but not limited to, lamps and tubing.

Contact Hach Company or your distributor to initiate warranty support. Products may not be returned without authorization from Hach Company.

Limitations

This warranty does not cover:

- Damage caused by acts of God, natural disaster, labor unrest, acts of war (declared or undeclared), terrorism, civil strife or acts of any governmental jurisdiction
- Damage caused by misuse, neglect, accident or improper application or installation
- Damage caused by any repair or attempted repair not authorized by Hach Company
- Any product not used in accordance with the instructions furnished by Hach Company
- Freight charges to return merchandise to Hach Company
- Freight charges on expedited or express shipment of warranted parts or product
- Travel fees associated with on-site warranty repair

This warranty contains the sole express warranty made by Hach Company in connection with its products. All implied warranties, including without limitation, the warranties of merchantability and fitness for a particular purpose, are expressly disclaimed.

Some states within the United States do not allow the disclaimer of implied warranties and if this is true in your state the above limitation may not apply to you. This warranty gives you specific rights, and you may also have other rights that vary from state to state.

This warranty constitutes the final, complete, and exclusive statement of warranty terms and no person is authorized to make any other warranties or representations on behalf of Hach Company.

Limitation of Remedies

The remedies of repair, replacement or refund of purchase price as stated above are the exclusive remedies for the breach of this warranty. On the basis of strict liability or under any other legal theory, in no event shall Hach Company be liable for any incidental or consequential damages of any kind for breach of warranty or negligence.

Appendix A Modbus Protocol

A.1 Introduction

Modbus was developed as a PLC communication protocol by Modicon in the late 1970s. Because Modbus is a well-defined and published standard, Modbus has become one of the best known protocols for interfacing digital equipment to PLCs.

Modbus uses a master/slave data exchange technique. The master (typically a PLC) generates queries to individual slaves. The slaves, in turn, reply back with a response to the master. A Modbus message contains the information required to send a query or request, including the slave address, function code, data, and a checksum.

The format of a Modbus message is shown below:

Address	Function	Data	Checksum
1 byte	1 byte	Variable number of bytes	2 bytes

A.2 Query Message

A query message is generated by the master to request data from a slave. It contains a function code that specifies the type and amount of data requested. A read digital input register function code (02), for example, instructs the slave to read digital inputs and return the value in a response message.

The following message instructs slave 1 to read two bits starting at offset 0.

Address	Function	Data		Checksum
		Start Register	Number of Points	
01	02	00 00	00 02	F9 CB

Note that the above values are hexadecimal bytes, not ASCII characters.

A.3 Response Message

A response message is generated by the slave in response to a query message from the master. The response to read digital input register function code (02), for example, returns the value of the requested digital inputs. The original slave address and function code is also returned to validate the response.

The following response is generated from the previous query if discrete input 1 is OFF (0) and discrete input 2 is ON (1).

Address	Function	Data		Checksum
		Byte Count	Digital Input Bits	
01	02	01	02	20 49

Again note that the above values are hexadecimal bytes, not ASCII characters.

A.4 Modbus Message Detail

The various fields within a Modbus message are described in more detail below.

Address

The address field is a single byte. This byte ranges in value from 1 to 247.

Function Codes

The function code is a single byte. Several function code values exist in Modbus. The ones supported by the sc100/Digital Sensor System are described below.

Function Code	Description	Data Type	Absolute Address	Relative Address
03	Read Holding Registers	Word (16 bits)	40001 to 49999	0 to 9998
06	Write Holding Register	Word (16 bits)	40001 to 49999	0 to 9998
08	Loopback Test	n/a	n/a	n/a
17	Report Slave ID	n/a	n/a	n/a

Only the relative address is specified in a message. The relative address is automatically added to the absolute address for that function code. If a read holding register message, for example, specifies relative address 0, the value in absolute address 40001 would be returned.

Data

The data field consists of a series of bytes. The number of bytes varies in length depending on the function code. Typical query message data consists of the relative address to be read by the slave. Typical response message data consists of actual data read by the slave.

Checksum

The checksum is two bytes which are appended to every message. These bytes ensure the data packet was transmitted with no errors. The algorithm which is applied to RTU messages is a 16 bit Cyclic Redundancy Check (CRC). The algorithm which is applied to ASCII messages is an 8 bit Longitudinal Redundancy Check (LRC).

ASCII / RTU Data Format

Modbus supports both ASCII and RTU data formats. RTU uses binary (non-printable) characters, and is used for normal operation. ASCII uses 7 bit printable characters, and is typically only used for debugging purposes.

The following tables show the same message in RTU and ASCII formats.

Table 8 RTU Message

Address	Function	Data		Checksum
		Start Register	Number of Points	
01	02	00 00	00 02	F9 CB

Table 9 ASCII Message

Colon	Address	Function	Data		Checksum	CR LF
			Start Register	Number of Points		
3A	30 31	30 32	30 30 30 30	30 30 30 32	46 42	0D 0A

Exception Codes

An illegal request will generate a Modbus Exception Code. The most common code is caused by reading data from an unused register. An exception response message consists of the slave address, the function code with the high order bit set, the exception code, and a CRC. In the following response message, the slave reported exception code 02, indicating an illegal data address.

Address	Function	Data	Checksum
01	81	02	C1 91

More Information

More information about the Modbus Protocol can be found on the Modbus-IDA website at www.modbus-ida.org.

A.5 Floating Point Measurements

Floating point measurements are available from the sc100/Digital Sensor system. Each floating point number is a 32-bit IEEE-754 value, occupying two 16-bit registers (back-to-back); this has one sign bit, eight exponent bits and 23 mantissa bits, and is stored in Motorola (big-endian) order.

A.5.1 Big-endian and Little-endian

Big-endian and little-endian are terms that describe the order in which a sequence of bytes are stored in the computer memory. Big-endian is an order in which the "big end" (most significant value) is stored first (lowest storage address). Little-endian is an order in which the "little end" (least significant value in the sequence) is stored first. For example, in a big-endian computer, the two bytes required for the hexadecimal number 4F52 would be stored as 4F52 in storage (if 4F is stored at storage address 1000, for example, 52 will be at address 1001). In a little-endian system, it would be stored as 524F (52 at address 1000, 4F at 1001).

The sc100/Digital Sensor registers are big-endian byte order within a register and little-endian word order for multi-registers Floats.

A.5.2 Changing the "endian" Order

The default "endian" order is little-endian word order for multi-registers Floats (SWAPPED order). The order can be changed in the NETWORK SETUP menu to NORMAL order (big-endian word order for multi-registers Floats).

A.6 Modbus Troubleshooting

Table 10 Troubleshooting

Problem	Possible Causes	Solution
No Modbus Response	Baud rate, or stop bits does not match settings of Modbus master	Verify sc100 settings match the Modbus master settings. Verify Modbus master Parity setting is set to None.
	Bad RS232 or RS485 cable	Replace/Repair cable
	No or improper network biasing and termination.	Check all network devices for termination or biasing settings. Only the ends of the network should have termination turned on and only one point on the network should be providing biasing.
	Slave Address incorrect or duplicate address of another bus device.	Verify all addresses are unique and between 1 and 247.
Modbus Exception Response	Register not supported	Verify register is supported
	Data Type incorrect	Verify the requested register(s) Data Type matches the Modbus Master Request e.g. do not access a Slave Float value with a 2 byte Integer request. When requesting a Float (2 registers/4 bytes), both registers must be requested at the same time.

Table 11 sc100 Modbus Registers

Group Name	Tag Name	Register #	Data Type	Length	R/W	Description
Measurements	Calculated Value	40001	Float	2	R	Value calculated from two sensor measurements
Setup	Language	40003	Unsigned Integer	1	R/W	Current System Language
Setup	Date Format	40004	Unsigned Integer	1	R/W	Current Data Display Format (0 = DD/MM/YY; 1 = MM/DD/YY; 2 = DD-MM-YY; 3 = MM-DD-YY)
Setup	Error Hold Mode	40005	Unsigned Integer	1	R/W	Error Mode Hold State (0 = Hold outputs; 1 = Transfer outputs to predefined value)
Setup/Analog Output 1	Source	40006	Unsigned Integer	1	R/W	Selects data source for this output (0 = None; 2 = sensor; 4 = Calculation)
Setup/Analog Output 1	Sensor Select	40007	Unsigned Integer	1	R/W	Selects sensor source when Source = Sensor (0 = sensor1; 1 = sensor2)
Setup/Analog Output 1	Measurement Select	40008	Unsigned Integer	1	R/W	Selects measurement on the sensor (0 = Meas1.. 3 = Meas4)
Setup/Analog Output 1	Type	40009	Unsigned Integer	1	R/W	Selects output type (0 = Linear output; 1 = PID control)
Setup/Analog Output 1	Transfer Value	40010	Float	2	R/W	Sets the transfer value
Setup/Analog Output 1	Filter	40012	Unsigned Integer	1	R/W	Sets the output filter value in seconds (0 to 120 sec.)
Setup/Analog Output 1	0mA - 4mA Select	40013	Unsigned Integer	1	R/W	Selects 0mA/4mA for min output (0 = 0mA; 1 = 4mA)
Setup/Analog Output 1/Linear	Min Setting	40014	Float	2	R/W	Sets the min output value
Setup/Analog Output 1/Linear	Max Setting	40016	Float	2	R/W	Sets the max output value

Table 11 sc100 Modbus Registers (continued)

Group Name	Tag Name	Register #	Data Type	Length	R/W	Description
Setup/Analog Output 1/PID	PID Mode	40018	Unsigned Integer	1	R/W	Sets the PID mode (0 = auto; 1 = manual)
Setup/Analog Output 1/PID	PID Manual Set	40019	Float	2	R/W	Sets the PID manual output value (0.0 to 100.0%)
Setup/Analog Output 1/PID	PID Setpoint	40021	Float	2	R/W	Sets the PID setpoint
Setup/Analog Output 1/PID	PID Phase	40023	Unsigned Integer	1	R/W	Sets the PID phase (0 = Direct; 1 = Reverse)
Setup/Analog Output 1/PID	PID Proportional Band	40024	Float	2	R/W	Sets the PID proportional band
Setup/Analog Output 1/PID	PID Integral Time	40026	Unsigned Integer	1	R/W	Sets the PID integral time (min)
Setup/Analog Output 1/PID	PID Derivative Time	40027	Unsigned Integer	1	R/W	Sets the PID derivative time (min)
Setup/Analog Output 2	Source	40028	Unsigned Integer	1	R/W	Selects data source for this output (0 = None; 2 = Sensor; 4 = Calculation)
Setup/Analog Output 2	Sensor Select	40029	Unsigned Integer	1	R/W	Selects sensor source when Source = Sensor (0 = Sensor1; 1 = Sensor2)
Setup/Analog Output 2	Measurement Select	40030	Unsigned Integer	1	R/W	Selects measurement on the Sensor (0 = Meas1 .. 3 = Meas4)
Setup/Analog Output 2	Type	40031	Unsigned Integer	1	R/W	Selects output type (0 = Linear output; 1 = PID control)
Setup/Analog Output 2	Transfer Value	40032	Float	2	R/W	Sets the transfer value
Setup/Analog Output 2	Filter	40034	Unsigned Integer	1	R/W	Sets the output filter value in seconds (0 to 120 sec)
Setup/Analog Output 2	0mA - 4mA Select	40035	Unsigned Integer	1	R/W	Selects 0mA/4mA for min output (0 = 0mA; 1 = 4mA)
Setup/Analog Output 2/Linear	Min Setting	40036	Float	2	R/W	Sets the min output value
Setup/Analog Output 2/Linear	Max Setting	40038	Float	2	R/W	Sets the max output value
Setup/Analog Output 2/PID	Mode	40040	Unsigned Integer	1	R/W	Sets the PID mode (0 = auto; 1 = manual)
Setup/Analog Output 2/PID	Manual Set	40041	Float	2	R/W	Sets the PID manual output value (0.0 to 100.0%)
Setup/Analog Output 2/PID	Setpoint	40043	Float	2	R/W	Sets the PID setpoint
Setup/Analog Output 2/PID	Phase	40045	Unsigned Integer	1	R/W	Sets the PID phase (0 = Direct; 1 = Reverse)
Setup/Analog Output 2/PID	Proportional Band	40046	Float	2	R/W	Sets the PID proportional band
Setup/Analog Output 2/PID	Integral Time	40048	Unsigned Integer	1	R/W	Sets the PID integral time (min)
Setup/Analog Output 2/PID	Derivative Time	40049	Unsigned Integer	1	R/W	Sets the PID derivative time (min)

Table 11 sc100 Modbus Registers (continued)

Group Name	Tag Name	Register #	Data Type	Length	R/W	Description
Setup/Relay 1	Source	40050	Unsigned Integer	1	R/W	Selects data source for this relay (0 = None; 1 = Real Time Clock; 2 = Sensor; 4 = Calculation)
Setup/Relay 1	Sensor Select	40051	Unsigned Integer	1	R/W	Selects Sensor source when Source = Sensor (0 = Sensor1; 1 = Sensor2)
Setup/Relay 1	Measurement Select	40052	Unsigned Integer	1	R/W	Selects measurement on the Sensor (0 = Meas1 .. 3 = Meas4)
Setup/Relay 1	Type	40053	Unsigned Integer	1	R/W	Selects the relay type (0 = Alarm; 1 = Control; 2 = Status; 3 = Timer; 4 = Event)
Setup/Relay 1	Transfer Setting	40054	Unsigned Integer	1	R/W	Selects the transfer value for the relays (0 = De-energized; 1 = Energized)
Setup/Relay 1/Alarm	High Alarm	40055	Float	2	R/W	Sets the high alarm setpoint
Setup/Relay 1/Alarm	Low Alarm	40057	Float	2	R/W	Sets the low alarm setpoint
Setup/Relay 1/Alarm	High Deadband	40059	Float	2	R/W	Sets the high alarm deadband
Setup/Relay 1/Alarm	Low Deadband	40061	Float	2	R/W	Sets the low alarm deadband
Setup/Relay 1/Alarm	On Delay	40063	Unsigned Integer	1	R/W	Sets the on delay time
Setup/Relay 1/Alarm	Off Delay	40064	Unsigned Integer	1	R/W	Sets the off delay time
Setup/Relay 1/Control	Setpoint	40065	Float	2	R/W	Sets the controller setpoint
Setup/Relay 1/Control	Phase	40067	Unsigned Integer	1	R/W	Sets the controller phase (0 = Low; 1 = High)
Setup/Relay 1/Control	Deadband	40068	Float	2	R/W	Sets the controller deadband
Setup/Relay 1/Control	Overfeed Timer	40070	Unsigned Integer	1	R/W	Sets the overfeed timer value (mins)
Setup/Relay 1/Control	On Delay	40071	Unsigned Integer	1	R/W	Sets the on delay time (sec)
Setup/Relay 1/Control	Off Delay	40072	Unsigned Integer	1	R/W	Sets the off delay time (sec)
Setup/Relay 1/Control	Reset Overfeed Timer	40073	Unsigned Integer	1	R/W	Resets the overfeed timer
Setup/Relay 1/Event	Setpoint	40074	Float	2	R/W	Sets the event setpoint
Setup/Relay 1/Event	Phase	40076	Unsigned Integer	1	R/W	Sets the event phase (0 = Low; 1 = High)
Setup/Relay 1/Event	Deadband	40077	Float	2	R/W	Sets the event deadband
Setup/Relay 1/Event	On Max Time	40079	Unsigned Integer	1	R/W	Sets the max on time (mins)
Setup/Relay 1/Event	On Min Time	40080	Unsigned Integer	1	R/W	Sets the min on time (mins)
Setup/Relay 1/Event	Off Max Time	40081	Unsigned Integer	1	R/W	Sets the max off time (mins)
Setup/Relay 1/Event	Off Min Time	40082	Unsigned Integer	1	R/W	Sets the min off time (mins)

Table 11 sc100 Modbus Registers (continued)

Group Name	Tag Name	Register #	Data Type	Length	R/W	Description
Setup/Relay 1/Timer	Hold Type	40083	Unsigned Integer	1	R/W	Sets which Sensor outputs are affected during timer on time (0 = None; 2 = Selected Sensor; 13 = All Sensors)
Setup/Relay 1/Timer	Sensor Select	40084	Unsigned Integer	1	R/W	Selects which Sensor outputs are being held/transferred during the timers on time (this is used when Hold type is set for single Sensor)
Setup/Relay 1/Timer	Hold Mode	40085	Unsigned Integer	1	R/W	Selects hold outputs vs. set transfer value during timers on time
Setup/Relay 1/Timer	Duration Time	40086	Unsigned Integer	1	R/W	Sets the timer on duration time (sec)
Setup/Relay 1/Timer	Period Time	40087	Unsigned Integer	1	R/W	Sets the period between timer on events (mins)
Setup/Relay 1/Timer	Off Delay	40088	Unsigned Integer	1	R/W	Sets the time the affected Sensor outputs are held/transferred after the timer turns off (sec)
Setup/Relay 1/Status	Level	40089	Unsigned Integer	1	R/W	Sets the status level which will trigger the relay
Setup/Relay 2	Source	40090	Unsigned Integer	1	R/W	Selects data source for this relay (0 = None; 1 = Real Time Clock; 2 = Sensor; 4 = Calculation)
Setup/Relay 2	Sensor Select	40091	Unsigned Integer	1	R/W	Selects Sensor source when Source = Sensor (0 = Sensor1; 1 = Sensor2)
Setup/Relay 2	Measurement Select	40092	Unsigned Integer	1	R/W	Selects measurement on the Sensor (0 = Meas1 .. 3 = Meas4)
Setup/Relay 2	Type	40093	Unsigned Integer	1	R/W	Selects the relay type (0 = Alarm; 1 = Control; 2 = Status; 3 = Timer; 4 = Event)
Setup/Relay 2	Transfer Setting	40094	Unsigned Integer	1	R/W	Selects the transfer value for the relays (0 = De-energized; 1 = Energized)
Setup/Relay 2/Alarm	High Alarm	40095	Float	2	R/W	Sets the high alarm setpoint
Setup/Relay 2/Alarm	Low Alarm	40097	Float	2	R/W	Sets the low alarm setpoint
Setup/Relay 2/Alarm	High Deadband	40099	Float	2	R/W	Sets the high alarm deadband
Setup/Relay 2/Alarm	Low Deadband	40101	Float	2	R/W	Sets the low alarm deadband
Setup/Relay 2/Alarm	On Delay	40103	Unsigned Integer	1	R/W	Sets the on delay time
Setup/Relay 2/Alarm	Off Delay	40104	Unsigned Integer	1	R/W	Sets the off delay time
Setup/Relay 2/Control	Setpoint	40105	Float	2	R/W	Sets the controller setpoint
Setup/Relay 2/Control	Phase	40107	Unsigned Integer	1	R/W	Sets the controller phase (0 = Low; 1 = High)
Setup/Relay 2/Control	Deadband	40108	Float	2	R/W	Sets the controller deadband
Setup/Relay 2/Control	Overfeed Timer	40110	Unsigned Integer	1	R/W	Sets the overfeed timer value (mins)
Setup/Relay 2/Control	On Delay	40111	Unsigned Integer	1	R/W	Sets the on delay time (sec)
Setup/Relay 2/Control	Off Delay	40112	Unsigned Integer	1	R/W	Sets the off delay time (sec)

Table 11 sc100 Modbus Registers (continued)

Group Name	Tag Name	Register #	Data Type	Length	R/W	Description
Setup/Relay 2/Control	Reset Overfeed Timer	40113	Unsigned Integer	1	R/W	Resets the overfeed timer
Setup/Relay 2/Event	Setpoint	40114	Float	2	R/W	Sets the event setpoint
Setup/Relay 2/Event	Phase	40116	Unsigned Integer	1	R/W	Sets the event phase (0 = Low; 1 = High)
Setup/Relay 2/Event	Deadband	40117	Float	2	R/W	Sets the event deadband
Setup/Relay 2/Event	On Max Time	40119	Unsigned Integer	1	R/W	Sets the max on time (mins)
Setup/Relay 2/Event	On Min Time	40120	Unsigned Integer	1	R/W	Sets the min on time (mins)
Setup/Relay 2/Event	Off Max Time	40121	Unsigned Integer	1	R/W	Sets the max off time (mins)
Setup/Relay 2/Event	Off Min Time	40122	Unsigned Integer	1	R/W	Sets the min off time (mins)
Setup/Relay 2/Timer	Hold Type	40123	Unsigned Integer	1	R/W	Sets which Sensor outputs are affected during timer on time (0 = None; 2 = Selected Sensor; 13 = All Sensors)
Setup/Relay 2/Timer	Sensor Select	40124	Unsigned Integer	1	R/W	Selects which Sensor outputs are being held/transferred during the timers on time (this is used when Hold type is set for single Sensor)
Setup/Relay 2/Timer	Hold Mode	40125	Unsigned Integer	1	R/W	Selects hold outputs vs. set transfer value during timers on time
Setup/Relay 2/Timer	Duration Time	40126	Unsigned Integer	1	R/W	Sets the timer on duration time (sec)
Setup/Relay 2/Timer	Period Time	40127	Unsigned Integer	1	R/W	Sets the period between timer on events (mins)
Setup/Relay 2/Timer	Off Delay	40128	Unsigned Integer	1	R/W	Sets the time the affected Sensor outputs are held/transferred after the timer turns off (sec)
Setup/Relay 2/Status	Level	40129	Unsigned Integer	1	R/W	Sets the status level which will trigger the relay
Setup/Relay 3	Source	40130	Unsigned Integer	1	R/W	Selects data source for this relay (0 = None; 1 = Real Time Clock; 2 = Sensor; 4 = Calculation)
Setup/Relay 3	Sensor Select	40131	Unsigned Integer	1	R/W	Selects Sensor source when Source = Sensor (0 = Sensor1; 1 = Sensor2)
Setup/Relay 3	Measurement Select	40132	Unsigned Integer	1	R/W	Selects measurement on the Sensor (0 = Meas1 .. 3 = Meas4)
Setup/Relay 3	Type	40133	Unsigned Integer	1	R/W	Selects the relay type (0 = Alarm; 1 = Control; 2 = Status; 3 = Timer; 4 = Event)
Setup/Relay 3	Transfer Setting	40134	Unsigned Integer	1	R/W	Selects the transfer value for the relays (0 = De-energized; 1 = Energized)
Setup/Relay 3/Alarm	High Alarm	40135	Float	2	R/W	Sets the high alarm setpoint
Setup/Relay 3/Alarm	Low Alarm	40137	Float	2	R/W	Sets the low alarm setpoint
Setup/Relay 3/Alarm	High Deadband	40139	Float	2	R/W	Sets the high alarm deadband

Table 11 sc100 Modbus Registers (continued)

Group Name	Tag Name	Register #	Data Type	Length	R/W	Description
Setup/Relay 3/Alarm	Low Deadband	40141	Float	2	R/W	Sets the low alarm deadband
Setup/Relay 3/Alarm	On Delay	40143	Unsigned Integer	1	R/W	Sets the on delay time
Setup/Relay 3/Alarm	Off Delay	40144	Unsigned Integer	1	R/W	Sets the off delay time
Setup/Relay 3/Control	Setpoint	40145	Float	2	R/W	Sets the controller setpoint
Setup/Relay 3/Control	Phase	40147	Unsigned Integer	1	R/W	Sets the controller phase (0 = Low; 1 = High)
Setup/Relay 3/Control	Deadband	40148	Float	2	R/W	Sets the controller deadband
Setup/Relay 3/Control	Overfeed Timer	40150	Unsigned Integer	1	R/W	Sets the overfeed timer value (mins)
Setup/Relay 3/Control	On Delay	40151	Unsigned Integer	1	R/W	Sets the on delay time (sec)
Setup/Relay 3/Control	Off Delay	40152	Unsigned Integer	1	R/W	Sets the off delay time (sec)
Setup/Relay 3/Control	Reset Overfeed Timer	40153	Unsigned Integer	1	R/W	Resets the overfeed timer
Setup/Relay 3/Event	Setpoint	40154	Float	2	R/W	Sets the event setpoint
Setup/Relay 3/Event	Phase	40156	Unsigned Integer	1	R/W	Sets the event phase (0 = Low; 1 = High)
Setup/Relay 3/Event	Deadband	40157	Float	2	R/W	Sets the event deadband
Setup/Relay 3/Event	On Max Time	40159	Unsigned Integer	1	R/W	Sets the max on time (mins)
Setup/Relay 3/Event	On Min Time	40160	Unsigned Integer	1	R/W	Sets the min on time (mins)
Setup/Relay 3/Event	Off Max Time	40161	Unsigned Integer	1	R/W	Sets the max off time (mins)
Setup/Relay 3/Event	Off Min Time	40162	Unsigned Integer	1	R/W	Sets the min off time (mins)
Setup/Relay 3/Timer	Hold Type	40163	Unsigned Integer	1	R/W	Sets which Sensor outputs are affected during timer on time (0 = None; 2 = Selected Sensor; 13 = All Sensors)
Setup/Relay 3/Timer	Sensor Select	40164	Unsigned Integer	1	R/W	Selects which Sensor outputs are being held/transferred during the timers on time (this is used when Hold type is set for single Sensor)
Setup/Relay 3/Timer	Hold Mode	40165	Unsigned Integer	1	R/W	Selects hold outputs vs. set transfer value during timers on time
Setup/Relay 3/Timer	Duration Time	40166	Unsigned Integer	1	R/W	Sets the timer on duration time (sec)
Setup/Relay 3/Timer	Period Time	40167	Unsigned Integer	1	R/W	Sets the period between timer on events (mins)
Setup/Relay 3/Timer	Off Delay	40168	Unsigned Integer	1	R/W	Sets the time the affected Sensor outputs are held/transferred after the timer turns off (sec)
Setup/Relay 3/Status	Level	40169	Unsigned Integer	1	R/W	Sets the status level which will trigger the relay

Table 11 sc100 Modbus Registers (continued)

Group Name	Tag Name	Register #	Data Type	Length	R/W	Description
Comm/Net Card	Mode	40170	Unsigned Integer	1	R/W	Sets the Modbus mode (0 = RTU; 1 = ASCII)
Comm/Net Card	Baud	40171	Unsigned Integer	1	R/W	Sets the Modbus baud rate (0 = 9600; 1 = 19200; 2 = 38400; 3 = 57600; 4 = 115200)
Comm/Net Card	Stop Bits	40172	Unsigned Integer	1	R/W	Sets the number of stop bits (1,2)
Comm/Net Card	Data Order	40173	Unsigned Integer	1	R/W	Sets the register data order for floats (0 = Normal; 1 = Reversed)
Comm/Net Card	Min Response Time	40174	Unsigned Integer	1	R/W	Sets the minimum response time (0 to 30 sec)
Comm/Net Card	Max Response Time	40175	Unsigned Integer	1	R/W	Sets the maximum response time (100 to 1000 sec)
Comm/Net Card/Addresses	sc100	40176	Unsigned Integer	1	R/W	Sets the sc100 Modbus Address
Comm/Net Card/Addresses	Sensor 1	40177	Unsigned Integer	1	R/W	Sets the Sensor 1 Modbus Address
Comm/Net Card/Addresses	Sensor 2	40178	Unsigned Integer	1	R/W	Sets the Sensor 2 Modbus Address
Comm/Net Card/Stats	Good Messages	40179	Unsigned Integer	2	R/W	Number of good messages
Comm/Net Card/Stats	Bad Messages	40181	Unsigned Integer	2	R/W	Number of failed messages
Comm/Net Card/Stats	% Good Mesg	40183	Float	2	R/W	% of good messages
Comm/Service Port	Mode	40185	Unsigned Integer	1	R/W	Sets the Modbus mode (0 = RTU; 1 = ASCII)
Comm/Service Port	Baud	40186	Unsigned Integer	1	R/W	Sets the Modbus baud rate (0 = 9600; 1 = 19200; 2 = 38400; 3 = 57600; 4 = 115200)
Comm/Service Port	Stop Bits	40187	Unsigned Integer	1	R/W	Sets the number of stop bits (1,2)
Comm/Service Port	Data Order	40188	Unsigned Integer	1	R/W	Sets the register data order for floats (0 = Normal; 1 = Reversed)
Comm/Service Port	Min Response Time	40189	Unsigned Integer	1	R/W	Sets the minimum response time (0 to 30 sec)
Comm/Service Port	Max Response Time	40190	Unsigned Integer	1	R/W	Sets the maximum response time (100 to 1000 sec)
Comm/Service Port/Addresses	sc100	40191	Unsigned Integer	1	R/W	Sets the sc100 Modbus Address
Comm/Service Port/Addresses	Sensor 1	40192	Unsigned Integer	1	R/W	Sets the Sensor 1 Modbus Address
Comm/Service Port/Addresses	Sensor 2	40193	Unsigned Integer	1	R/W	Sets the Sensor 2 Modbus Address
Comm/Service Port/Stats	Good Messages	40194	Unsigned Integer	2	R/W	Number of good messages

Table 11 sc100 Modbus Registers (continued)

Group Name	Tag Name	Register #	Data Type	Length	R/W	Description
Comm/Service Port/Stats	Bad Messages	40196	Unsigned Integer	2	R/W	Number of failed messages
Comm/Service Port/Stats	% Good Mesg	40198	Float	2	R/W	% of good messages
Comm/Sensor/ Sensor1 Stats	Good Messages	40200	Unsigned Integer	2	R/W	Number of good messages
Comm/Sensor/ Sensor1 Stats	Bad Messages	40202	Unsigned Integer	2	R/W	Number of failed messages
Comm/Sensor/ Sensor1 Stats	% Good Mesg	40204	Float	2	R/W	% of good messages
Comm/Sensor/ Sensor2 Stats	Good Messages	40206	Unsigned Integer	2	R/W	Number of good messages
Comm/Sensor/ Sensor2 Stats	Bad Messages	40208	Unsigned Integer	2	R/W	Number of failed messages
Comm/Sensor/ Sensor2 Stats	% Good Mesg	40210	Float	2	R/W	% of good messages
Calibration	Output1 4mA count	40212	Unsigned Integer	1	R/W	Calibration counts for the 4mA output 1
Calibration	Output1 20mA count	40213	Unsigned Integer	1	R/W	Calibration counts for the 20mA output 1
Calibration	Output2 4mA count	40214	Unsigned Integer	1	R/W	Calibration counts for the 4mA output 2
Calibration	Output2 20mA count	40215	Unsigned Integer	1	R/W	Calibration counts for the 20mA output 2

A		
Alarms	18	
Analog Outputs	19	
C		
Cleaning		
Controller	39	
Compliance Information	43	
Components		
Customer Supplied	7	
Configuring		
System	30	
Controller		
Enclosure Description	5	
D		
Date		
Setting	30	
Digital Output	23	
Display	28	
Contrast	29	
E		
Electrical Installation	13	
Conduit	14	
Connecting/Wiring the Sensor Cable	20	
Power Cord	14	
Electrostatic Discharge	13	
F		
Fuse		
Rating	39	
Replacement	39	
H		
hard-wired electrical applications	14	
I		
Installation	9	
Controller	11	
Panel	10	
Panel Mounting	12	
Pipe Mounting	11	
	Wall Mounting	11
K		
Key		
Functions	27	
Keypad	27	
L		
Language		
Displayed	29	
M		
Modbus RS232	24, 41	
Modbus RS485	41	
O		
Output		
Connections	20	
Outputs	19	
P		
Parts	41	
R		
Relays	18	
Connecting	18, 19	
Specifications	3	
Replacement	41	
S		
Security		
Setup	37	
System	31	
Specifications	3	
T		
Time		
Setting	30	
W		
Warranty	47	
Wire preparation	15	
Wiring Safety	13	
