

# TOMAHAWK™ 625

For use with machines having Code Number: **11580**

## Safety Depends on You

Lincoln arc welding and cutting equipment is designed and built with safety in mind. However, your overall safety can be increased by proper installation ... and thoughtful operation on your part. **DO NOT INSTALL, OPERATE OR REPAIR THIS EQUIPMENT WITHOUT READING THIS MANUAL AND THE SAFETY PRECAUTIONS CONTAINED THROUGHOUT.** And, most importantly, think before you act and be careful.



## OPERATOR'S MANUAL



**LINCOLN**®  
**ELECTRIC**

Copyright © Lincoln Global Inc.

- World's Leader in Welding and Cutting Products •
- Sales and Service through Subsidiaries and Distributors Worldwide •

Cleveland, Ohio 44117-1199 U.S.A. TEL: 216.481.8100 FAX: 216.486.1751 WEB SITE: [www.lincolnelectric.com](http://www.lincolnelectric.com)

## ! WARNING

PLASMA CUTTING or GOUGING can be hazardous.

**PROTECT YOURSELF AND OTHERS FROM POSSIBLE SERIOUS INJURY OR DEATH. KEEP CHILDREN AWAY. PACEMAKER WEARERS SHOULD CONSULT WITH THEIR DOCTOR BEFORE OPERATING.**

Read and understand the following safety highlights. For additional safety information it is strongly recommended that you purchase a copy of "Safety in Welding & Cutting - ANSI Standard Z49.1" from the American Welding Society, P.O. Box 351040, Miami, Florida 33135 or CSA Standard W117.2.

**BE SURE THAT ALL INSTALLATION, OPERATION, MAINTENANCE, AND REPAIR PROCEDURES ARE PERFORMED ONLY BY QUALIFIED INDIVIDUALS.**



### ELECTRIC SHOCK can kill.

1.a. The electrode and work (or ground) circuits are electrically "hot" when the power source is on. Do not touch these "hot" parts with your bare skin or wet clothing. Wear dry, hole-free gloves to insulate hands.

- 1.b. When the power source is operating voltages in excess of 250 volts are produced. This creates the potential for serious electrical shock - potentially even fatal.
- 1.c. Insulate yourself from work and ground using dry insulation. When cutting or gouging in damp locations, on metal framework such as floors, gratings or scaffolds and when in positions such as sitting or lying, make certain the insulation is large enough to cover your full area of physical contact with work and ground.
- 1.d. Always be sure the work cable makes a good electrical connection with the metal being cut or gouged. The connection should be as close as possible to the area being cut or gouged.
- 1.e. Ground the work or metal to be cut or gouged to a good electrical (earth) ground.
- 1.f. Maintain the plasma torch, cable and work clamp in good, safe operating condition. Replace damaged insulation.
- 1.g. Never dip the torch in water for cooling or plasma cut or gouge in or under water.
- 1.h. When working above floor level, protect yourself from a fall should you get a shock.
- 1.i. Operate the pilot arc with caution. The pilot arc is capable of burning the operator, others or even piercing safety clothing.
- 1.j. Also see Items 4c and 6.



### FUMES AND GASES can be dangerous.

3.a. Plasma cutting or gouging may produce fumes and gases hazardous to health. Avoid breathing these fumes and gases. When cutting or gouging, keep your head out of the fumes. Use enough ventilation and/or exhaust at the arc to keep fumes and gases away from the breathing zone. **When plasma cutting or gouging on lead or cadmium plated steel and other metals or coatings which produce highly toxic fumes, keep exposure as low as possible and within applicable OSHA PEL and ACGIH TLV limits using local exhaust or mechanical ventilation. In confined spaces or in some circumstances, outdoors, a respirator may be required. Additional precautions are also required when welding on galvanized steel.**

- 3.b. The operation of plasma cutting or gouging fume control equipment is affected by various factors including proper use and positioning of the equipment, maintenance of the equipment and the specific procedure and application involved. Worker exposure level should be checked upon installation and periodically thereafter to be certain it is within applicable OSHA PEL and ACGIH TLV limits.
- 3.c. Do not use plasma cutting or gouging equipment in locations near chlorinated hydrocarbon vapors coming from degreasing, cleaning or spraying operations. The heat and rays of the arc can react with solvent vapors to form phosgene, a highly toxic gas, and other irritating products.
- 3.d. Gases used for plasma cutting and gouging can displace air and cause injury or death. Always use enough ventilation, especially in confined areas, to insure breathing air is safe.
- 3.e. Read and understand the manufacturer's instructions for this equipment and follow your employer's safety practices.



### ARC RAYS can burn.

2.a. Use safety glasses and a shield with the proper filter and cover plates to protect your eyes from sparks and the rays of the arc when performing or observing plasma arc cutting or gouging. Glasses, headshield and filter lens should conform to ANSI Z87.1 standards.

- 2.b. Use suitable clothing including gloves made from durable flame-resistant material to protect your skin and that of your helpers from the arc rays.
- 2.c. Protect other nearby personnel with suitable non-flammable screening and/or warn them not to watch the arc nor expose themselves to the arc rays or to hot spatter or metal.



### CUTTING SPARKS can cause fire or explosion.

4.a. Remove fire hazards from the plasma cutting or gouging area. If this is not possible, cover them to prevent the cutting or gouging sparks from starting a fire. Remember that welding sparks and hot materials from plasma cutting or gouging can easily go through small cracks and openings to adjacent areas. Avoid cutting or gouging near hydraulic lines. Have a fire extinguisher readily available.

- 4.b. Where compressed gases are to be used at the job site, special precautions should be used to prevent hazardous situations. Refer to "Safety in Welding and Cutting" (ANSI Standard Z49.1) and the operating information for the equipment being used.

- 4.c. When not cutting or gouging, make certain no part of the electrode circuit is touching the work or ground. Accidental contact can cause overheating and create a fire hazard.
- 4.d. Do not cut or gouge tanks, drums or containers until the proper steps have been taken to insure that such procedures will not cause flammable or toxic vapors from substances inside. They can cause an explosion even though they have been "cleaned." For information purchase "Recommended Safe Practices for the Preparation for Welding and Cutting of Containers and Piping That Have Held Hazardous Substances", AWS F4.1 from the American Welding Society (see address above).
- 4.e. Vent hollow castings or containers before heating, cutting or gouging. They may explode.
- 4.f. Do not fuel engine driven equipment near area where plasma cutting or gouging.
- 4.g. Sparks and spatter are thrown from the plasma arc. Wear safety glasses, ear protection and oil free protective garments such as leather gloves, heavy shirt, cuffless trousers, high shoes and a cap over your hair. Wear ear plugs when cutting or gouging out of position or in confined places. Always wear safety glasses with side shields when in a cutting or gouging area.
- 4.h. Connect the work cable to the work as close to the cutting or gouging area as practical. Work cables connected to the building framework or other locations away from the cutting or gouging area increase the possibility of the current passing through lifting chains, crane cables or other alternate circuits. This can create fire hazards or overheat lifting chains or cables until they fail.
- 4.i. Read and follow NFPA 51B "Standard for Prevention During Welding, Cutting and Other Hot Work", available from NFPA, 1 Batterymarch Park, PO box 9101, Quincy, Ma 022690-9101.



### CYLINDER may explode if damaged.

5.a. Use only compressed gas cylinders containing the correct gas for the process used and properly operating regulators designed for the gas and pressure used. All hoses, fittings, etc. should be suitable for the application and maintained in good condition.

- 5.b. Always keep cylinders in an upright position securely chained to an undercarriage or fixed support.
- 5.c. Cylinders should be located:
- Away from areas where they may be struck or subjected to physical damage.
  - A safe distance from plasma cutting or gouging, arc welding operations and any other source of heat, sparks, or flame.
- 5.d. Never allow any part of the electrode, torch or any other electrically "hot" parts to touch a cylinder.
- 5.e. Keep your head and face away from the cylinder valve outlet when opening the cylinder valve.
- 5.f. Valve protection caps should always be in place and hand tight except when the cylinder is in use or connected for use.
- 5.g. Read and follow the instructions on compressed gas cylinders, associated equipment, and CGA publication P-1, "Precautions for Safe Handling of Compressed Gases in Cylinders," available from the Compressed Gas Association 1235 Jefferson Davis Highway, Arlington, VA 22202.



### FOR ELECTRICALLY powered equipment.

- 6.a. Turn off input power using the disconnect switch at the fuse box before working on the equipment.
- 6.b. Install equipment in accordance with the U.S. National Electrical Code, all local codes and the manufacturer's recommendations.
- 6.c. Ground the equipment in accordance with the U.S. National Electrical Code and the manufacturer's recommendations.



### PLASMA ARC can injure.

- 7.a. Keep your body away from nozzle and plasma arc.
- 7.b. Operate the pilot arc with caution. The pilot arc is capable of burning the operator, others or even piercing safety clothing.



### ELECTRIC AND MAGNETIC FIELDS may be dangerous

- 8.a. Electric current flowing through any conductor causes localized Electric and Magnetic Fields (EMF). Cutting or gouging current creates EMF fields around torch cables and cutting machines.
- 8.b. EMF fields may interfere with some pacemakers, so operators having a pacemaker should consult their physician before cutting or gouging.
- 8.c. Exposure to EMF fields during cutting or gouging may have other health effects which are now not known.
- 8.d. All operators should use the following procedures in order to minimize exposure to EMF fields from the cutting or gouging circuit:
- 8.d.1. Route the torch and work cables together - Secure them with tape when possible.
  - 8.d.2. Never coil the torch cable around your body.
  - 8.d.3. Do not place your body between the torch and work cables. If the torch cable is on your right side, the work cable should also be on your right side.
  - 8.d.4. Connect the work cable to the workpiece as close as possible to the area being cut or gouged.
  - 8.d.5. Do not work next to cutting power source.

Refer to <http://www.lincolnelectric.com/safety> for additional safety information.

# NOTES

## PRÉCAUTIONS DE SÛRETÉ

Pour votre propre protection lire et observer toutes les instructions et les précautions de sûreté spécifiques qui paraissent dans ce manuel aussi bien que les précautions de sûreté générales suivantes:

### Sûreté Pour Soudage A L'Arc

1. Protégez-vous contre la secousse électrique:
  - a. Les circuits à l'électrode et à la pièce sont sous tension quand la machine à souder est en marche. Eviter toujours tout contact entre les parties sous tension et la peau nue ou les vêtements mouillés. Porter des gants secs et sans trous pour isoler les mains.
  - b. Faire très attention de bien s'isoler de la masse quand on soude dans des endroits humides, ou sur un plancher métallique ou des grilles métalliques, principalement dans les positions assis ou couché pour lesquelles une grande partie du corps peut être en contact avec la masse.
  - c. Maintenir le porte-électrode, la pince de masse, le câble de soudage et la machine à souder en bon et sûr état de fonctionnement.
  - d. Ne jamais plonger le porte-électrode dans l'eau pour le refroidir.
  - e. Ne jamais toucher simultanément les parties sous tension des porte-électrodes connectés à deux machines à souder parce que la tension entre les deux pinces peut être le total de la tension à vide des deux machines.
  - f. Si on utilise la machine à souder comme une source de courant pour soudage semi-automatique, ces précautions pour le porte-électrode s'appliquent aussi au pistolet de soudage.
2. Dans le cas de travail au dessus du niveau du sol, se protéger contre les chutes dans le cas où on recoit un choc. Ne jamais enrouler le câble-électrode autour de n'importe quelle partie du corps.
3. Un coup d'arc peut être plus sévère qu'un coup de soliel, donc:
  - a. Utiliser un bon masque avec un verre filtrant approprié ainsi qu'un verre blanc afin de se protéger les yeux du rayonnement de l'arc et des projections quand on soude ou quand on regarde l'arc.
  - b. Porter des vêtements convenables afin de protéger la peau de soudeur et des aides contre le rayonnement de l'arc.
  - c. Protéger l'autre personnel travaillant à proximité au soudage à l'aide d'écrans appropriés et non-inflammables.
4. Des gouttes de laitier en fusion sont émises de l'arc de soudage. Se protéger avec des vêtements de protection libres de l'huile, tels que les gants en cuir, chemise épaisse, pantalons sans revers, et chaussures montantes.
5. Toujours porter des lunettes de sécurité dans la zone de soudage. Utiliser des lunettes avec écrans latéraux dans les zones où l'on pique le laitier.

6. Eloigner les matériaux inflammables ou les recouvrir afin de prévenir tout risque d'incendie dû aux étincelles.
7. Quand on ne soude pas, poser la pince à un endroit isolé de la masse. Un court-circuit accidentel peut provoquer un échauffement et un risque d'incendie.
8. S'assurer que la masse est connectée le plus près possible de la zone de travail qu'il est pratique de le faire. Si on place la masse sur la charpente de la construction ou d'autres endroits éloignés de la zone de travail, on augmente le risque de voir passer le courant de soudage par les chaînes de levage, câbles de grue, ou autres circuits. Cela peut provoquer des risques d'incendie ou d'échauffement des chaînes et des câbles jusqu'à ce qu'ils se rompent.
9. Assurer une ventilation suffisante dans la zone de soudage. Ceci est particulièrement important pour le soudage de tôles galvanisées plombées, ou cadmiées ou tout autre métal qui produit des fumées toxiques.
10. Ne pas souder en présence de vapeurs de chlore provenant d'opérations de dégraissage, nettoyage ou pistilage. La chaleur ou les rayons de l'arc peuvent réagir avec les vapeurs du solvant pour produire du phosgène (gas fortement toxique) ou autres produits irritants.
11. Pour obtenir de plus amples renseignements sur la sûreté, voir le code "Code for safety in welding and cutting" CSA Standard W 117.2-1974.

## PRÉCAUTIONS DE SÛRETÉ POUR LES MACHINES À SOUDER À TRANSFORMATEUR ET À REDRESSEUR

1. Relier à la terre le châssis du poste conformément au code de l'électricité et aux recommandations du fabricant. Le dispositif de montage ou la pièce à souder doit être branché à une bonne mise à la terre.
2. Autant que possible, l'installation et l'entretien du poste seront effectués par un électricien qualifié.
3. Avant de faire des travaux à l'intérieur de poste, la débrancher à l'interrupteur à la boîte de fusibles.
4. Garder tous les couvercles et dispositifs de sûreté à leur place.

**Thank You** — for selecting a **QUALITY** product by Lincoln Electric. We want you to take pride in operating this Lincoln Electric Company product ... as much pride as we have in bringing this product to you!

#### CUSTOMER ASSISTANCE POLICY

The business of The Lincoln Electric Company is manufacturing and selling high quality welding equipment, consumables, and cutting equipment. Our challenge is to meet the needs of our customers and to exceed their expectations. On occasion, purchasers may ask Lincoln Electric for advice or information about their use of our products. We respond to our customers based on the best information in our possession at that time. Lincoln Electric is not in a position to warrant or guarantee such advice, and assumes no liability, with respect to such information or advice. We expressly disclaim any warranty of any kind, including any warranty of fitness for any customer's particular purpose, with respect to such information or advice. As a matter of practical consideration, we also cannot assume any responsibility for updating or correcting any such information or advice once it has been given, nor does the provision of information or advice create, expand or alter any warranty with respect to the sale of our products.

Lincoln Electric is a responsive manufacturer, but the selection and use of specific products sold by Lincoln Electric is solely within the control of, and remains the sole responsibility of the customer. Many variables beyond the control of Lincoln Electric affect the results obtained in applying these types of fabrication methods and service requirements.

Subject to Change – This information is accurate to the best of our knowledge at the time of printing. Please refer to [www.lincolnelectric.com](http://www.lincolnelectric.com) for any updated information.

#### **Please Examine Carton and Equipment For Damage Immediately**

When this equipment is shipped, title passes to the purchaser upon receipt by the carrier. Consequently, Claims for material damaged in shipment must be made by the purchaser against the transportation company at the time the shipment is received.

Please record your equipment identification information below for future reference. This information can be found on your machine nameplate.

Product \_\_\_\_\_

Model Number \_\_\_\_\_

Code Number or Date Code \_\_\_\_\_

Serial Number \_\_\_\_\_

Date Purchased \_\_\_\_\_

Where Purchased \_\_\_\_\_

Whenever you request replacement parts or information on this equipment, always supply the information you have recorded above. The code number is especially important when identifying the correct replacement parts.

#### **On-Line Product Registration**

- Register your machine with Lincoln Electric either via fax or over the Internet.
- For faxing: Complete the form on the back of the warranty statement included in the literature packet accompanying this machine and fax the form per the instructions printed on it.
- For On-Line Registration: Go to our **WEB SITE at [www.lincolnelectric.com](http://www.lincolnelectric.com)**. Choose "Support" and then "Register Your Product". Please complete the form and submit your registration.

**Read this Operators Manual completely** before attempting to use this equipment. Save this manual and keep it handy for quick reference. Pay particular attention to the safety instructions we have provided for your protection. The level of seriousness to be applied to each is explained below:

#### **⚠ WARNING**

This statement appears where the information **must** be followed **exactly** to avoid **serious personal injury** or **loss of life**.

#### **⚠ CAUTION**

This statement appears where the information **must** be followed to avoid **minor personal injury** or **damage to this equipment**.

<b>Installation</b> .....	<b>Section A</b>
Technical Specifications .....	A-1
Safety Precautions .....	A-2
Select Proper Location .....	A-2
Stacking.....	A-2
Tilting.....	A-2
High Frequency Interference Protection.....	A-2
Input Electrical Connections.....	A-2
Gas Input Connections.....	A-3
Output Connections.....	A-3
Torch .....	A-3
<hr/>	
<b>Operation</b> .....	<b>Section B</b>
Safety Precautions .....	B-1
Description .....	B-1
Preheat Temperature for Plasma Cutting.....	B-1
User Responsibility.....	B-2
Operational Features and Controls .....	B-2
Design Features and Advantages .....	B-2
Cutting Capability .....	B-3
Consumable Life .....	B-3
Limitations .....	B-4
Controls and Settings .....	B-4, B-5
Cutting Process .....	B-5, B-6
Pilot Arc Discussion.....	B-7
Procedure Recommendations.....	B-7
General .....	B-7
Suggestions for Extra Utility from the TOMAHAWK™ 625 System.....	B-8
Torch Part Configuration.....	B-9, B-10
<hr/>	
<b>Accessories</b> .....	<b>Section C</b>
<hr/>	
<b>Maintenance</b> .....	<b>Section D</b>
Safety Precautions .....	D-1
Routine Maintenance.....	D-1
Periodic Maintenance .....	D-1
<hr/>	
<b>Troubleshooting</b> .....	<b>Section E</b>
Safety Precautions.....	E-1
How to Use Troubleshooting Guide.....	E-1
Error Signals.....	E-2
Troubleshooting Guide .....	E-3 Thru E-7
<hr/>	
<b>Wiring Diagrams</b> .....	<b>Section F</b>
Wiring Diagram .....	F-1
<hr/>	
<b>Parts Lists</b> .....	<b>Appendix</b>
TOMAHAWK™ 625.....	P-626 Series
Torch.....	P-210-W

## TECHNICAL SPECIFICATIONS -TOMAHAWK™ 625

### INPUT - SINGLE PHASE 50 / 60 HERTZ

#### Standard Voltage

208V, 230V ±10% / 1 / 50 / 60Hz

### RATED OUTPUT AT 40° C

<u>Duty Cycle</u>	<u>CURRENT AMPS</u>	<u>VOLTAGE VOLTS</u>
100%	24 A	89.6VDC
60%	29 A	91.8VDC
35%	40 A	96.0VDC

### OUTPUT

<u>Current Range</u>	<u>Open Circuit Voltage</u>	<u>Pilot Current</u>
10-40 Amps	460 VDC	12 Amps

### REQUIRED GAS FLOW RATE

70 PSI @ 125-200 SCFH  
( 5 Bar. @ 80±20 LITERS/MIN.)

### REQUIRED GAS INLET PRESSURE

80 to 110 PSI  
(6 Bar. to 7.5 Bar.)

### RECOMMEND INPUT WIRE AND FUSE SIZES

For all plasma cutting applications  
Based on U.S. National Electrical Code  
Ambient Temperature 30°C or Less

Output	AC Input Voltage at 50/60 Hertz	Input Cord Plug Size	Fuse (Super Lag) Circuit Breaker (Delay Type)	Type S, SO, ST, STO or extra hard usage input cord AWG (IEC) Sizes	
				2 Input Supply Wires	1 Ground Wire
40 A	230V-1Ø 208V-1Ø	6-50P	30 AMPS	#12 (3.3 mm <sup>2</sup> )	#12 (3.3 mm <sup>2</sup> )

### PHYSICAL DIMENSIONS

<u>Height</u>	<u>Width</u>	<u>Depth</u>	<u>Weight Including Torch Cable</u>
15.2 in. 385 mm	8.5 in. 215 mm	18.9 in. 480 mm	34.0 lbs. 15.4 kg.

### TEMPERATURE RANGES

<u>OPERATING TEMPERATURE RANGE</u>	<u>STORAGE TEMPERATURE RANGE</u>
-10°C to +40°C	-10°C to +40°C

Read entire Installation Section before installing the TOMAHAWK™ 625.

## SAFETY PRECAUTIONS

### ⚠ WARNING

#### ELECTRIC SHOCK CAN KILL.



- Only qualified personnel should install this machine.
- Turn the input power OFF at the disconnect switch or fuse box and discharge input capacitors before working inside the equipment.
- Do not touch electrically hot parts.
- Turn the TOMAHAWK™ 625 Power Switch OFF when connecting power cord to input power.

## SELECT PROPER LOCATION

Place the TOMAHAWK™ 625 where clean cool air can freely circulate in and out of the side louvers. Dirt, dust or any foreign material that can be drawn into the machine should be kept at a minimum. Failure to observe these precautions can result in excessive operating temperatures and nuisance shutdown of the machine.

A source of clean, dry air or nitrogen must be supplied to the TOMAHAWK™ 625 when using external air supply. Oil in the air is a severe problem and must be avoided. The supply pressure must be between 80 and 150 psi. The flow rate is approximately 4.0 cfm (113 l/min.). Failure to observe these precautions could result in excessive operating temperatures or damage to the torch.

## STACKING

The TOMAHAWK™ 625 cannot be stacked.

## TILTING

The TOMAHAWK™ 625 must be placed on a stable, level surface so it will not topple over.

## HIGH FREQUENCY INTERFERENCE PROTECTION

The TOMAHAWK™ 625 employs a touch start mechanism for arc initiation which eliminates high frequency emissions from the machine as compared with spark gap and solid state type high frequency generators. Keep in mind, though, that these machines may be used in an environment where other high frequency generating machines are operating. By taking the following steps, high frequency interference into the TOMAHAWK™ 625 can be minimized

- (1) Make sure the power supply chassis is connected to a good earth ground. The work terminal ground does NOT ground the machine frame.
- (2) Keep the work clamp isolated from other work clamps that have high frequency.
- (3) If the work clamp cannot be isolated, then keep the clamp as far as possible from other work clamp connections.
- (4) When the machine is enclosed in a metal building, several good earth driven electrical grounds around the periphery of the building are recommended.

Failure to observe these recommended installation procedures may cause improper function of the TOMAHAWK™ 625 or possibly even damage to the control system or power supply components.

## INPUT ELECTRICAL CONNECTIONS

The TOMAHAWK™ 625 is rated for 208VAC and 230VAC input voltage. Before installing the machine, check that input supply voltage, phase, and frequency are the same as the machine's voltage, phase, and frequency as specified on the machine's rating plate.

- The TOMAHAWK™ 625 should be connected only by a qualified electrician. Installation should be made in accordance with local codes.

For use on engine drives, keep in mind the above input draw restrictions and the following precaution.

The TOMAHAWK™ 625 can be operated on engine driven generators as long as the 230 volt auxiliary meets the following conditions:

- The AC waveform peak voltage is below 400 volts.
- The AC waveform frequency is between 45 and 65 Hz.
- The RMS voltage of the AC waveform is always greater than 208VAC.

The following Lincoln engine drives meet these conditions when run in the high idle mode:

Outback 189, Ranger 225, 250, 250LPG, 305G and 305D engine drives.

Vantage 300, 400, 500 and Air Vantage engine drives.

Operation of the TOMAHAWK™ 625 is not recommended on engine drives not conforming to these conditions. Such combinations may overvoltage the TOMAHAWK™ 625 power source.

## GAS INPUT CONNECTIONS

(External Air Supply)

Supply the TOMAHAWK™ 625 with clean compressed air or nitrogen.

- Supply pressure must be between 80 psi and 110 psi.
- Flow rate should be approximately 125 - 200 SCFH (80 ±20 L/min).

**NOTE:** Oil in the air supply to the TOMAHAWK™ 625 can cause severe problems. Use only a clean air supply.

- Compressed gas can be supplied either through the air fitting supplied with the machine or through the 1/4-19 BSP thread at the rear of the machine. To use the air fitting supplied with the machine (packaged in the consumable kit), apply teflon tape to the fitting threads and install the fitting in the port at the rear of the machine.
- If compressed air is being used, it is highly recommended that an in line filter be installed in the air supply line ahead of the air connection to the TOMAHAWK™ 625.
- A standard nominal 5 micron in line filter is recommended; however, for optimum performance, select a prefilter with a 3 micron absolute rating.

If these filter ratings are unavailable, anything with a rating less than, or equal to, 20 micron would be acceptable to use. In line filter elements will generally filter the air with little restriction to the airflow until the element is about 75% contaminated. After this point, there will be a noticeable pressure drop in the line. Filter elements should be replaced when a pressure drop of 8-10 psi is indicated; however, for optimum performance of the TOMAHAWK™ 625, the filter element should be replaced at or before the pressure drop reaches 8 psi. Be sure to select a filter that will accommodate the necessary flow rating for the TOMAHAWK™ 625 as specified in the Installation section of this instruction manual under the Gas Input Connections heading.

**NOTE:** When using nitrogen gas from a cylinder, the cylinder must have a pressure regulator.

- Maximum psi from a nitrogen gas cylinder to the TOMAHAWK™ 625 regulator should never exceed 110 psi.
- Install a hose between the nitrogen gas cylinder regulator and the TOMAHAWK™ 625 gas inlet.

**CYLINDER** could explode if damaged.

### ⚠ WARNING



- Keep cylinder upright and chained to a fixed support.
- Keep cylinder away from areas where it could be damaged.
- Never lift machine with cylinder attached.
- Never allow the cutting torch to touch the cylinder.
- Keep cylinder away from live electrical parts.
- Maximum inlet pressure 110 psi.

## OUTPUT CONNECTIONS

### Torch

The TOMAHAWK™ 625 is sent from the factory with a cutting torch and work clamp included. The work clamp must be securely connected to the work piece. If the work piece is painted or extremely dirty it may be necessary to expose the bare metal in order to make a good electrical connection.

## SAFETY PRECAUTIONS

### WARNING



#### **ELECTRIC SHOCK can kill.**

- Do not touch electrically live parts or electrode with skin or wet clothing.
- Insulate yourself from work and ground.
- Always wear dry insulating gloves.



#### **FUMES AND GASES can be dangerous.**

- Keep your head out of fumes.
- Use ventilation or exhaust to remove fumes from breathing zone.



#### **WELDING, CUTTING and GOUGING SPARKS can cause fire or explosion**

- Keep flammable material away.
- Do not weld, cut or gouge on containers that have held combustibles.



#### **ARC RAYS can burn.**

- Wear eye, ear and body protection.



#### **PLASMA ARC can injure**

- Keep your body away from nozzle and plasma arc.
- Operate the pilot arc with caution. The pilot arc is capable of burning the operator, others or even piercing safety clothing.

Observe additional Safety Guidelines detailed in the beginning of this manual.

## DESCRIPTION

The TOMAHAWK™ 625 is a constant current, continuous control plasma cutting power source. It provides superior and reliable starting characteristics, cutting visibility and arc stability. The control system has a safety mechanism to insure that the nozzle and electrode are in place before cutting or gouging. This is extremely important due to the high voltages involved.

The TOMAHAWK™ 625 comes standard with an air regulator and pressure gauge. The machine also comes with an input power cord, Hand-held torch with a 20' cable length. Consumables are included with each TOMAHAWK™ 625 purchase so that cutting can begin right out of the box. Consumables can also be ordered as individual packages.

The TOMAHAWK™ 625 initiates the plasma arc with a simple, yet reliable, touch start mechanism. This system eliminates many of the failure problems associated with hi-frequency start systems.

## PREHEAT TEMPERATURE FOR PLASMA CUTTING

Preheat temperature control is not necessary in most applications when plasma arc cutting or gouging. Preheat temperature control may be necessary on high carbon alloy steels and heat treated aluminum for crack resistance and hardness control. Job conditions, prevailing codes, alloy level, and other considerations may also require preheat temperature control. The following minimum preheat temperature is recommended as a starting point. Higher temperatures may be used as required by the job conditions and/or prevailing codes. If cracking or excessive hardness occurs on the cut face, higher preheat temperature may be required. The recommended minimum preheat temperature for plate thickness up to 1/2" (12.7mm) is 70°F (21.1°C).

## USER RESPONSIBILITY

Because design, fabrication, erection and cutting variables affect the results obtained in applying this type of information, the serviceability of a product or structure is the responsibility of the user. Variation such as plate chemistry, plate surface condition (oil, scale), plate thickness, preheat, quench, gas type, gas flow rate and equipment may produce results different than those expected. Some adjustments to procedures may be necessary to compensate for unique individual conditions. Test all procedures duplicating actual field conditions.

## DESIGN FEATURES AND ADVANTAGES

The TOMAHAWK™ 625 design makes plasma cutting uncomplicated. This list of design features and advantages will help you understand the machine's total capabilities so that you can get maximum use from your machine.

- Light weight and portable design for industrial use.
- Continuous control, 10 - 40 amps.
- Reliable touch start mechanism for plasma arc initiation.
- Rapid arc restrike for fast cutting of expanded metal.
- Input over voltage protection.
- Bright 3.0 second timed pilot arc.
- Purge section on output dial.
- Air regulator and pressure gage included.
- Internal water separator included.
- Parts-in-Place mechanism to detect proper installation of consumables and torch.
- Preflow/Postflow timing. Preflow is eliminated if arc is re-initiated in Postflow.
- Thermostatic Protection.
- Solid state over-current protection.
- Unique electrode and nozzle design for optimum cooling and long life.

**CUTTING CAPABILITY**

The TOMAHAWK™ 625 is rated at 40 amps, at 35% duty cycle on a 10 minute basis. If the duty cycle is exceeded, a thermal protector will shut off the output of the machine until it cools to the normal operating temperature.

Figure B.1 shows the cut capacity of the TOMAHAWK™ 625 when cutting mild steel. (The graph plots cut thickness vs. torch travel speed with a torch standoff of 0.15".)

**CONSUMABLE LIFE**

The expected life for the TOMAHAWK™ 625's electrode under normal operating conditions is approximately 1000 starts/cuts. An erosion of .060" is typical for end of electrode life, however, the electrode life may last longer. A green and erratic arc will indicate definite electrode failure and the electrode should be replaced immediately.

It is recommended that consumables be replaced in complete sets. (Example: Electrode and Nozzle). This will maximize the performance of the TOMAHAWK™ 625 system.

Figure B.1

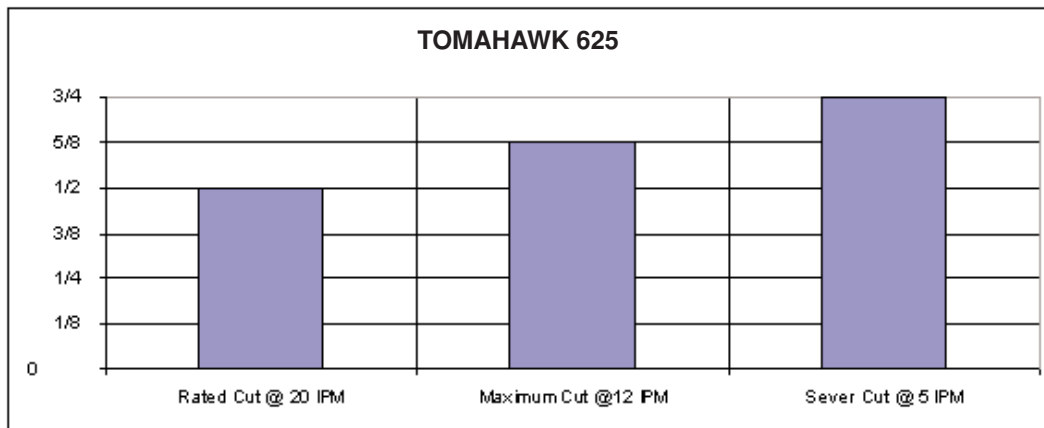
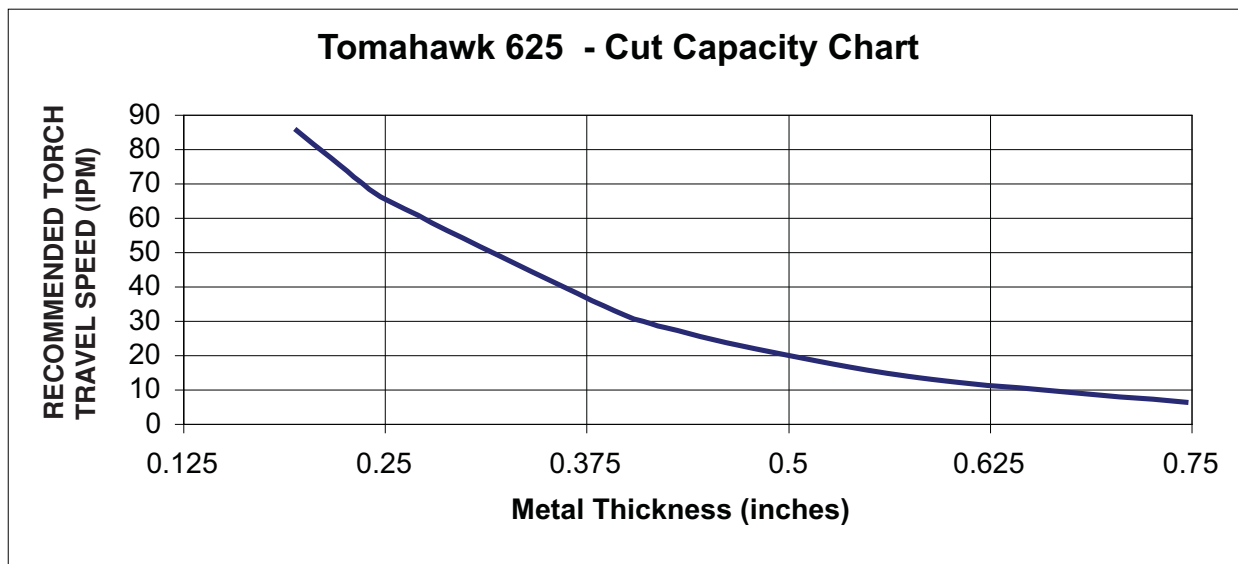

### LIMITATIONS

Do not exceed output current and duty cycle rating of machine. Do not use the TOMAHAWK™ 625 for pipe thawing.

If the arc turns off while cutting using low input voltage, that is below 208V, lower the air pressure by adjusting the regulator knob.

When using with the Outback 180, gouging is not recommended.

### CONTROLS AND SETTINGS

(Figure B.2)

TOMAHAWK™ 625 front command panel.

FIGURE B.2

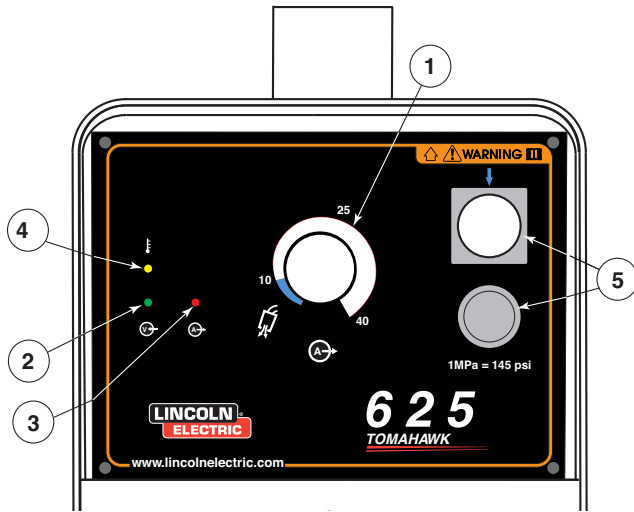

1. **Output Current Knob:** Potentiometer used to set the output current used during cutting. Refer to the Technical Specification section for more information about the machine's rated current range.

**Air Purge:** The Output Current Knob completely rotated counterclockwise enables the air purge function. A five minute timeout stops the purge function; this will occur only if the Output Current Knob remains in the purge mode for an extended time.

2. **Power ON/OFF green LED:** Illuminates when the machine is ON.

3. **Output red LED:** See the following table.

4. **Thermal yellow LED:** See the following table.

LEDs		Description
Output (Red)	Thermal (Yellow)	
On	Off	The cutting torch is energized.
On	On	<b>Part in place error:</b> the retaining cap is not properly Attached.  To restore the machine: <ul style="list-style-type: none"> <li>• Install the torch retaining cap firmly in place.</li> <li>• Wait for 5 seconds; during this time the output and thermal LED's blinks alternately.</li> <li>• After 5 seconds the machine is automatically restored and ready to operate.</li> </ul>
Off	On	The machine is overheated and the output has been disabled. This usually occurs when the duty cycle of the machine has been exceeded. Leave the machine On to allow the internal components to cool. When the thermal LED turns off, normal operation is again possible.
Off	Blink	<b>Power undervoltage error:</b> the machine is disabled. When the power returns to the correct range, the machine will restart automatically.
Blink	Off	Low air pressure error.  To check / adjust the air pressure (see recommended values in the Technical Specifications of this manual): <ul style="list-style-type: none"> <li>• Put the machine in Purge mode [1].</li> <li>• Check and adjust the air pressure using the pressure gauge and air pressure regulator knob [6].</li> <li>• If necessary, check and adjust also the inlet air pressure by adjusting the external compressor.</li> </ul>

**5. Air Pressure Gauge and Regulator Knob:** Allows regulation and monitoring of the air pressure.

**Items 6 thru 9 on the back of the TOMAHAWK™ 625 (See Figure B.3)**

**6. Fan:** Provides machine cooling. When the machine is switched ON, the fan runs continuously.

**7. Power Switch:** Turns ON / OFF the input power to the machine.

**8. Input cable:** Connects unit to the input power.

**9. Air Inlet:** External Air operating mode only. Compressed Air Connection.

## ⚠ WARNING

Clean, dry air must be supplied to the machine. A pressure setting above 110 PSI (7.5 bar) could damage the torch. Failure to observe these precautions could result in excessive operating temperatures or damage to the torch.

## CUTTING PROCESS

When preparing to cut, position the machine as close to the work as possible. Make sure to have all materials needed to complete the job and have taken all safety precautions. It is important to follow these operating steps each time the machine is used.

FIGURE B.3

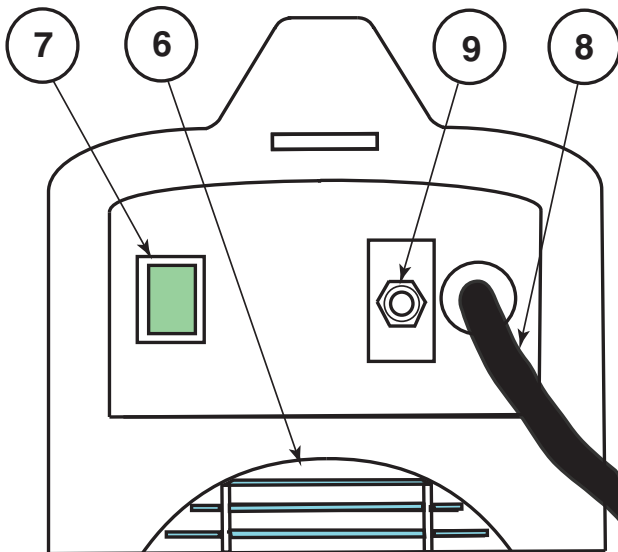

Turn the machine's ON/OFF POWER SWITCH to the OFF position.

- Connect the air supply to the machine.
- Turn the main power on and the machine power switch to the ON position.
  - The fan will start.
  - The pre-charge circuit will operate for 3 seconds, then the green "Power" LED will illuminate.
- Attach the work lead clamp to the workpiece before cutting.
- Set the output current control knob to maximum position for higher cutting speed and less dross formation. Reduce the current, if desired to reduce the kerf (cut) width, heat affected zone, or travel speed as required.

**Note:** If the circuit breaker trips while cutting at higher amperages - reduce the cutting amperage on the unit, or provide an input circuit with higher current capacity.

- Rotate the output knob into the purge zone to check or set the gas pressure. Pull the pressure regulator cap out and turn it to set the pressure.
  - Adjust the gas regulator for 75-80 PSI (0.50-0.55 MPa).
  - Turn the output knob out of the purge zone.
  - The gas will immediately turn off. The pressure gage may show an increase in pressure after the air turns off but this is normal. Do NOT reset the pressure while the air is NOT flowing.

- When ready to cut, place the torch near the work, make certain all safety precautions have been taken and pull the trigger.
  - The air will flow for a preflow time of 2 seconds and the pilot arc will start. (Exceptions: the first time that the trigger is pulled after the machine is turned on, or after a thermal trip out, initial trigger will be ignored. This is a safety feature to prevent the pilot arc from firing unexpectedly or if the torch trigger is inadvertently pressed. The other exception is if the machine is in postflow, then the preflow time is skipped and the pilot arc will start immediately.)
  - The pilot arc will run for 3.0 seconds and shut off unless the arc is brought in contact with the work and the arc is transferred. Avoid excessive pilot arc time by transferring the arc to the workpiece quickly. This will extend consumable life.
  - When the arc is brought within 1/8" - 1/4" from the work piece: the arc will transfer, the current will ramp to the setting on the control panel, and the cut can last indefinitely (or until the duty cycle of the TOMAHAWK™ 625 is exceeded).
- Pierce the work piece by slowly lowering the torch onto the metal at a 30° angle away from the operator. This will blow the dross away from the torch tip. Slowly rotate the torch to vertical position as the arc becomes deeper.

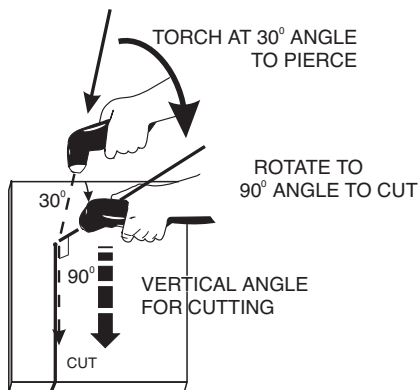

- Keep moving while cutting. Cut at a steady speed without pausing. Maintain the cutting speed so that the arc lag is 10° to 20° behind the travel direction.

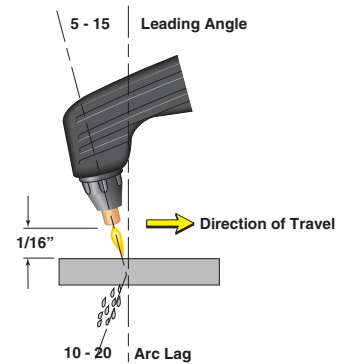

- Use a 5° - 15° leading angle in the direction of the cut.
- Finish the cut to be made and release the trigger.
- When the trigger is released, the arc will stop.
  - The gas will continue to flow for 15 seconds of postflow. If the trigger is activated within this time period, the pilot arc will immediately restart.
- If the dross is difficult to remove, reduce the cutting speed. High speed dross is more difficult to remove than low speed dross.

### ⚠ WARNING



#### ELECTRIC SHOCK CAN KILL.

- Turn off machine at the disconnect switch on the rear of the machine before tightening, cleaning or replacing consumables.

- Clean spatter and scale from the nozzle frequently.

### TORCH

- During operation, if the Red and Yellow LED's light together:
- Check the assembly of the torch consumables. If they are not properly in place, the machine will not start. **Make sure that the shield cup is hand tight. Do not use pliers or over tighten.**
- Check the conditions of the inside of the nozzle. If debris has collected, rub the electrode on the inside bottom of the nozzle to remove any oxide layer that may have built up. Refer to "Suggestions for Extra Utility from the TOMAHAWK™ 625 system".
- Check the condition of the electrode. If the end has a crater-like appearance, replace it along with the nozzle. The maximum wear depth of the electrode is approximately .062". A green and erratic arc will indicate definite electrode failure and the electrode should be replaced immediately.

- Replace the nozzle when the orifice exit is eroded away or oval shaped.
- After the problem is found, or if there is nothing apparently wrong, reset the machine by turning the power switch OFF and then ON again. (It is possible for electrical noise to trip the safety circuit on rare occasions. This should not be a regular occurrence.)
- If the machine does not reset or continues to trip, consult the Troubleshooting Section.
- Use the proper cutting procedures referred to in Procedure Recommendations.

## PILOT ARC DISCUSSION

The TOMAHAWK™ 625 has a smooth, continuous pilot arc. The pilot arc is only a means of transferring the arc to the workpiece for cutting. Repeated pilot arc starts, in rapid succession, is not recommended as these starts will generally reduce consumable life. Occasionally, the pilot arc may sputter or start intermittently. This is aggravated when the consumables are worn or the air pressure is too high. Always keep in mind that the pilot arc is designed to transfer the arc to the workpiece and not for numerous starts without cutting.

The TOMAHAWK™ 625 does not utilize high frequency starting. When the pilot arc is started, a slight impulse will be felt in the torch handle. This occurrence is normal and is the mechanism which starts the plasma arc. This impulse can also be used to help troubleshoot a "no start" condition.

## PROCEDURE RECOMMENDATIONS

When properly used, plasma arc cutting is a very economical process. Improper use will result in a very high operating cost.

### General - In All Cases

- Follow safety precautions as printed throughout this operating manual and on the machine.
- If piercing is required, slowly lower the torch at an angle of about 30° to blow the dross away from the torch tip and slowly rotate the torch to a vertical position as the arc becomes deeper. This process will blow a lot of molten metal and dross. Be careful! Blow the dross away from the torch, the operator and any flammable objects.
- The nozzle should not be dragged on the metal surface. A drag spacer is provided to maintain a consistent touch height. Refer to **Touch Parts Configurations** in this Section.

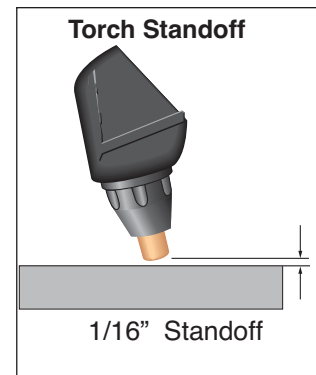

- Where possible, start the cut from the edge of the work piece.
- Keep moving! A steady speed is necessary. Do not pause.

## Suggestions for Extra Utility from the TOMAHAWK™ 625 System:

### WARNING



#### **ELECTRIC SHOCK CAN KILL.**

- Turn off machine at the disconnect switch on the rear of the machine before tightening, cleaning or replacing consumables.

1. Occasionally an oxide layer may form over the tip of the electrode, creating an insulating barrier between the electrode and nozzle. This will result in the tripping of the TOMAHAWK™ 625's safety circuit. When this happens turn the power off, remove the nozzle and electrode and use the electrode to rub against the inside bottom surface of the nozzle. This will help remove any oxide buildup. Replace the nozzle, turn on the power and continue cutting. If the safety circuit continues to trip after cleaning the consumables, then replace them with a new set. Do not continue to try and cut with excessively worn consumables as this can cause damage to the torch head and will degrade cut quality. Do not allow torch cable or body to contact hot surface.
2. To improve consumable life, here are some suggestions that may be useful:
  - Make sure the air supply to the TOMAHAWK™ 625 is clean and free of oil. Use several extra in line filters if necessary.
  - Minimize dross buildup on the nozzle tip by starting the cut from the edge of the plate when possible.
  - Pierce cutting should be done only when necessary. If piercing, angle torch about 30° from the plane perpendicular to the work piece, transfer the arc, then bring the torch perpendicular to the work and begin parallel movement.
  - Reduce the number of pilot arc starts without transferring to the work.
  - Reduce the pilot arc time before transferring to the work.

- Set air pressure to recommended setting. A higher or lower pressure will cause turbulence in the plasma arc, eroding the orifice of the nozzle tip.
- Use only Lincoln consumable parts. These parts are patented and using any other replacement consumables may cause damage to the torch or reduce cut quality.

**LC40 Parts** **LINCOLN**  
**ELECTRIC**

**HANDLE**  
W0300601R  
S28173-1

**HEAD**  
W0300600R  
S28174-1

**COOLING KIT**  
W03X0893-4R  
S28174-3

**ELECTRODE**  
W03X0893-1A  
KP2843-1

---

**Standard**

**SWIRL RING**  
W03X0893-5R  
KP2842-4

**NOZZLE**  
40A - W03X0893-2A  
40A - KP2843-2

**RETAINING CAP**  
W03X0893-10A  
KP2843-5

**SPACER**  
W03X0893-14R  
KP2843-10

---

**Contact**

**SWIRL RING**  
W03X0893-5R  
KP2842-4

**NOZZLE DIR CONTACT**  
25A - W03X0893-18A  
25A - KP2843-9  
40A - W03X0893-8A  
40A - KP2843-3

**RETAINING CAP**  
W03X0893-10A  
KP2843-5

---

**Gouging**

**SWIRL RING**  
W03X0893-5R  
KP2842-4

**GOUGE NOZZLE**  
W03X0893-9A  
KP2843-4

**RETAINING CAP**  
W03X0893-11A  
KP2843-6

**GOUGE SHIELD**  
W03X0893-13A  
KP2843-8

[www.lincolnelectric.com](http://www.lincolnelectric.com)

### TORCH PART CONFIGURATIONS

There are different torch configurations depending on the cutting or gouging application.

#### Standard Cutting Setup:

In the Standard Cutting configuration the nozzle is designed not to touch the work piece. The advantage of this cutting method is good visibility of the arc. However it requires a steady hand to avoid touching the nozzle to the work piece which will cause premature nozzle wear and a jagged cut. An optional drag spacer can be attached to the retaining cap to maintain a consistent arc height.

STANDARD

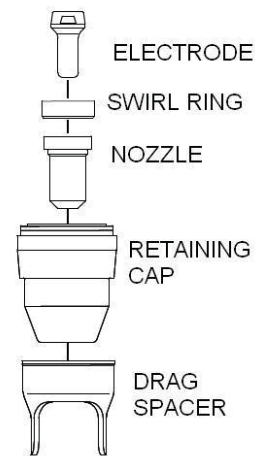

#### Contact Cutting Setup:

Contact Cutting uses special expendable parts that allow the torch to touch the work piece. The advantage of contact cutting is that the torch can touch the work piece, steadily dragging it across the surface. The disadvantage of contact cutting is the plasma arc is not as visible as with a standard torch set-up. Since this machine cuts at 40 amps or less it uses the direct contact torch configuration which allows a special nozzle to come in contact with the work piece.

DIRECT CONTACT

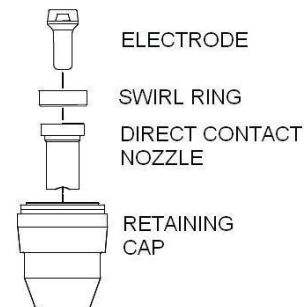

**LC40 Parts**

**HANDLE**  
W0300601R  
S28173-1

**HEAD**  
W0300600R  
S28174-1

**COOLING KIT**  
W03X0893-4R  
S28174-3

**ELECTRODE**  
W03X0893-1A  
KP2843-1

---

**Standard**

**SWIRL RING**  
W03X0893-5R  
KP2842-4

**NOZZLE**  
40A - W03X0893-2A  
40A - KP2843-2

**RETAINING CAP**  
W03X0893-10A  
KP2843-5

**SPACER**  
W03X0893-14R  
KP2843-10

---

**Contact**

**SWIRL RING**  
W03X0893-5R  
KP2842-4

**NOZZLE**  
DIR CONTACT  
25A - W03X0893-18A  
25A - KP2843-9  
40A - W03X0893-8A  
40A - KP2843-3

**RETAINING CAP**  
W03X0893-10A  
KP2843-5

---

**Gouging**

**SWIRL RING**  
W03X0893-5R  
KP2842-4

**GOUGE NOZZLE**  
W03X0893-9A  
KP2843-4

**RETAINING CAP**  
W03X0893-11A  
KP2843-6

**GOUGE SHIELD**  
W03X0893-13A  
KP2843-8

[www.lincolnelectric.com](http://www.lincolnelectric.com)

**Gouging Setup:**

If gouging metal and not cutting completely through the part is required, a special gouging nozzle is used in conjunction with a gouge shield to protect the nozzle from molten metal blow back.

GOUGING

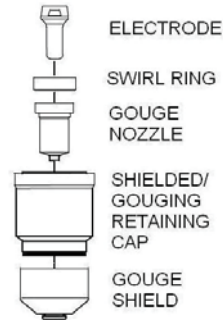

Refer to the torch parts decal located on your machine or the parts pages at the back of this manual for the specific part numbers required for each of these setups.

**ALWAYS USE GENUINE LINCOLN ELECTRIC ELECTRODES, NOZZLES, AND EXPENDABLE PARTS FOR THE BEST CUTTING PERFORMANCE.**

## GENERAL OPTIONS /ACCESSORIES

The following options/accessories are available for your Tomahawk Plasma cutter from your local Lincoln Distributor.

### **K2377-1 - Small Canvas Cover**

Protect your machine when not in use. Made from attractive red canvas that is flame retardant, mildew resistant and water repellent. It includes a convenient side pocket to hold the plasma torch.

### **K2886-1 - Plasma Circle Cutting Kit**

For cutting circles from 3" to 33" in diameter (77mm to 838mm).

## TORCHES

The following replacement torch is available:

**K2847-1 LC40** Handheld Plasma Torch 20' (6m)

## EXPENDABLE PARTS

Refer to the torch parts decal located on your machine or the parts pages at the back of this manual for the specific part numbers required for each of the available setups.

**⚠ WARNING****ELECTRIC SHOCK CAN KILL.**

- Have an electrician install and service this equipment.
- Turn the input power off at the fuse box before working on equipment.
- Do not touch electrically hot parts.

**ROUTINE MAINTENANCE**

1. Keep the cutting or gouging area and the area around the machine clean and free of combustible materials. No debris should be allowed to collect which could obstruct air flow to the machine.
2. Every 6 months or so, the machine should be cleaned with a low pressure airstream. Keeping the machine clean will result in cooler operation and higher reliability. Be sure to clean these areas:
  - Printed circuit boards and heat sinks
  - Power switch

**⚠ CAUTION**

- **When using a low pressure air stream, wear appropriate eye protection.**
3. Examine the sheet metal case for dents or breakage. Repair the case as required. Keep the case in good condition to insure that high voltage parts are protected and correct spacings are maintained. All external sheet metal screws must be in place to insure case strength and electrical ground continuity.
  4. Inspect the cable periodically for any slits or puncture marks in the cable jacket. Replace if necessary. Check to make sure that nothing is crushing the cable and blocking the flow of air through the air tube inside. Also, check for kinks in the cable periodically and relieve any so as not to restrict the flow of air to the torch.

**PERIODIC MAINTENANCE****⚠ WARNING****ELECTRIC SHOCK CAN KILL.**

- Turn off machine at the disconnect switch on the rear of the machine before tightening, cleaning or replacing consumables.

Change consumables as required.

**THERMAL PROTECTION**

Thermal Detection Devices protect the machine from excessive operating temperatures. Excessive temperatures may be caused by a lack of cooling air or operating the machine beyond the duty cycle and output rating. If excessive operating temperatures should occur, the yellow thermal LED will light and the Detection Devices will prevent output voltage or current.

These Detection Devices are self-resetting once the machine cools sufficiently. If the thermostat shutdown was caused by excessive output or duty cycle and the fan is operating normally, the Power Switch may be left on and the reset should occur within a 15 minute period. If the fan is not turning or the air intake louvers were obstructed, then the power must be switched off and the fan problem or air obstruction must be corrected.

A protection circuit is included to monitor the voltage across filter capacitors. In the event that the capacitor voltage is too high, the protection circuit will prevent output.

## HOW TO USE TROUBLESHOOTING GUIDE

### WARNING

Service and Repair should only be performed by Lincoln Electric Factory Trained Personnel. Unauthorized repairs performed on this equipment may result in danger to the technician and machine operator and will invalidate your factory warranty. For your safety and to avoid Electrical Shock, please observe all safety notes and precautions detailed throughout this manual.

This Troubleshooting Guide is provided to help you locate and repair possible machine malfunctions. Simply follow the three-step procedure listed below.

**Step 1. LOCATE PROBLEM (SYMPTOM).**

Look under the column labeled “PROBLEM (SYMPTOMS)”. This column describes possible symptoms that the machine may exhibit. Find the listing that best describes the symptom that the machine is exhibiting.

**Step 2. POSSIBLE CAUSE.**

The second column labeled “POSSIBLE CAUSE” lists the obvious external possibilities that may contribute to the machine symptom.

**Step 3. RECOMMENDED COURSE OF ACTION**

This column provides a course of action for the Possible Cause, generally it states to contact you local Lincoln Authorized Field Service Facility.

If you do not understand or are unable to perform the Recommended Course of Action safely, contact you local Lincoln Authorized Field Service Facility.

### WARNING

#### ELECTRIC SHOCK CAN KILL.



- Turn off machine at the disconnect switch on the rear of the machine and remove main power supply connections before doing any troubleshooting.

### CAUTION

If for any reason you do not understand the test procedures or are unable to perform the tests/repairs safely, contact your **Local Lincoln Authorized Field Service Facility** for technical troubleshooting assistance before you proceed.

TOMAHAWK™ 625



## ERROR SIGNALS

Alarm (abnormal condition)	RED LED	YELLOW LED	Blinking fre- quency (Hz)	Reset mode	NOTE
Undervoltage	OFF	Blink	1	Autoreset with hysteresis.	Error and shutdown when the input voltage is less than 187Vac.
Overvoltage signal	Blink	OFF	4	Autoreset with hysteresis.	Error when the input voltage is greater than 270Vac.
Underpressure	Blink	OFF	1	Autoreset.	Error and shutdown when the input air pressure is low.
PIP (Parts In Place)	ON	ON	steady on	Autoreset after 5sec.	Error and shutdown when the retaining cap is not attached properly.
Thermal Shutdown	OFF	ON	steady on	Autoreset after cooling time.	Normal thermal response due to overheating.
OCV	Blink	Blink	1	Autoreset after trigger release.	Safe Mode - if trigger is pulled while turning the machine on, or attaching consumables with the trigger pulled.
Overvoltage shutdown	OFF	Blink	3	Autoreset after 2min of cooling time.	This shutdown occurs if the machine cuts for more than 20sec in overvoltage condition (Vin>270Vac).

Signal (normal operation)	GREEN LED	RED LED	Blinking fre- quency (Hz)	Reset mode	NOTE
Power on	ON	OFF	steady on	Always on when the machine is energized.	Normal operating condition when trigger is off.
Inverter on	ON	ON	steady on	When the torch trigger is released.	Normal operating condition when trigger is pulled.

Observe all Safety Guidelines detailed throughout this manual

PROBLEMS (SYMPTOMS)	POSSIBLE CAUSE	RECOMMENDED COURSE OF ACTION
Input circuit breaker trips repeatedly.	<ol style="list-style-type: none"> <li>1. This may be normal. If output is set to maximum a 30 amp circuit is required. See Technical Specification page.</li> <li>2. Install a larger input circuit or turn the output control to a lower amperage.</li> </ol>	<p>If all recommended possible areas of misadjustment have been checked and the problem persists, <b>Contact your local Lincoln Authorized Field Service Facility.</b></p>
No Status indicators light and the fan does not operate 5 seconds after the power switch is turned on.	<ol style="list-style-type: none"> <li>1. Check the input power to be sure it is on.</li> <li>2. Check the power line fuses or breakers and machine connection.</li> <li>3. Disconnect input power at fuse/breaker panel and check line switch continuity. Replace line switch if bad.</li> </ol>	
No Status indicators light 5 seconds after the power switch is turned on, but the fan operates.	<ol style="list-style-type: none"> <li>1. Possible faulty Inverter Board.</li> <li>2. Possible faulty Control Board.</li> </ol>	
The Thermal LED does not go out.	<ol style="list-style-type: none"> <li>1. Check consumables - Thermal and output LED's light when an unsafe condition exists at the torch.</li> <li>2. Possible faulty Inverter Board.</li> <li>3. Possible faulty Control Board.</li> </ol>	

 **CAUTION**

If for any reason you do not understand the test procedures or are unable to perform the tests/repairs safely, contact your **Local Lincoln Authorized Field Service Facility** for technical troubleshooting assistance before you proceed.

TOMAHAWK™ 625



Observe all Safety Guidelines detailed throughout this manual

PROBLEMS (SYMPTOMS)	POSSIBLE CAUSE	RECOMMENDED COURSE OF ACTION
<p>The TOMAHAWK™ 625 powers up properly but there is no response when the trigger is pulled and only the POWER LED is lit.</p>	<ol style="list-style-type: none"> <li>1. Turn the output knob to purge zone on the front of the TOMAHAWK™ 625. If air does not flow, then: <ul style="list-style-type: none"> <li>• The main gas solenoid assembly/pressure sensor may be faulty. Check or replace.</li> <li>• Possible faulty Control board.</li> </ul> </li> <li>2. Remove the handles (or barrel) of the torch and examine all the connections.</li> <li>3. Check for proper trigger switch operation. Replace the trigger switch or torch cable if defective.</li> <li>4. Possible faulty Inverter Board.</li> <li>5. Possible faulty Control board.</li> </ol>	<p>If all recommended possible areas of misadjustment have been checked and the problem persists, <b>Contact your local Lincoln Authorized Field Service Facility.</b></p>

 **CAUTION**

If for any reason you do not understand the test procedures or are unable to perform the tests/repairs safely, contact your **Local Lincoln Authorized Field Service Facility** for technical troubleshooting assistance before you proceed.

TOMAHAWK™ 625



Observe all Safety Guidelines detailed throughout this manual

PROBLEMS (SYMPTOMS)	POSSIBLE CAUSE	RECOMMENDED COURSE OF ACTION
When the trigger is pulled air begins to flow, but there is no pilot arc after at least 3 seconds.	<ol style="list-style-type: none"> <li>1. Check the torch consumables to be sure they are not dirty or greasy, and are in good shape. Replace the consumables if necessary.</li> <li>2. Make sure the air pressure is set correctly.</li> <li>3. Make sure there are no kinks or restrictions for air flow in the torch cable. Replace cable as needed.</li> <li>4. If a slight thump cannot be felt in the torch when the trigger is pulled, check for loose connection in the torch head.</li> <li>5. Possible faulty Inverter board.</li> </ol>	<p>If all recommended possible areas of misadjustment have been checked and the problem persists, <b>Contact your local Lincoln Authorized Field Service Facility.</b></p>
The air begins to flow and there is a very brief arc that snaps out consistently with repeated trigger pulls.	<ol style="list-style-type: none"> <li>1. Check the torch consumables to be sure they are in tight, not dirty or greasy and in good shape. Replace if necessary.</li> <li>2. Make sure the air pressure is set correctly.</li> <li>3. Possible faulty Inverter board.</li> </ol>	
The arc starts but sputters badly.	<ol style="list-style-type: none"> <li>1. Check the torch consumables to be sure they are in tight, not dirty or greasy and in good shape. Replace if necessary.</li> <li>2. Check air supply for oil or a great deal of water. If there is oil or a great deal of water, the air must be filtered or the machine switched to nitrogen or bottled air.</li> <li>3. Make sure the air pressure is set correctly.</li> </ol>	

 **CAUTION**

If for any reason you do not understand the test procedures or are unable to perform the tests/repairs safely, contact your **Local Lincoln Authorized Field Service Facility** for technical troubleshooting assistance before you proceed.

TOMAHAWK™ 625



Observe all Safety Guidelines detailed throughout this manual

PROBLEMS (SYMPTOMS)	POSSIBLE CAUSE	RECOMMENDED COURSE OF ACTION
Pilot arc starts but will not transfer when brought near work.	<ol style="list-style-type: none"> <li>1. Check work lead connection for clean, secure connection.</li> <li>2. Plasma will only cut conductive material. Do not attempt to cut fiberglass, plastic, rubber, PVC or any other non-conductive material.</li> <li>3. Make sure work piece is clean and dry. Remove any scale, rust or dross.</li> <li>4. Possible faulty Inverter board.</li> <li>5. Check all connections to Control Board.</li> </ol>	<p>If all recommended possible areas of misadjustment have been checked and the problem persists, <b>Contact your local Lincoln Authorized Field Service Facility.</b></p>
Pilot arc initiates but turns off before transferring to work. Cutting arc appears to turn off while cutting.	<ol style="list-style-type: none"> <li>1. Input voltage is below 208V.</li> <li>2. Air pressure is set too high.</li> </ol>	<p>Lower air pressure by turning regulator knob. Pressure may require being set lower than blue arrow indicator.</p>

 **CAUTION**

If for any reason you do not understand the test procedures or are unable to perform the tests/repairs safely, contact your **Local Lincoln Authorized Field Service Facility** for technical troubleshooting assistance before you proceed.

TOMAHAWK™ 625



Observe all Safety Guidelines detailed throughout this manual

### STATUS BOARD INDICATORS

SYMPTOM	CHECK
When trigger is pulled Red output LED is Blinking or steady with no air flow.	<ol style="list-style-type: none"> <li>1. Make sure there is at least 80 psi connected to the gas connection at the back of the machine.</li> <li>2. Turn the output knob to the purge zone and set the regulator to the correct pressure. The pressure may increase when air stops flowing but this is normal. Do not reset the pressure while the air is OFF.</li> <li>3. Possible faulty Pressure Switch.</li> <li>4. Possible faulty Inverter board.</li> </ol>
The Green, Red and Yellow LED's are lit and steady. Indicates safety circuit is open.	<ol style="list-style-type: none"> <li>1. Turn the power OFF and then ON. If torch and consumables are properly installed and they are the correct parts, the Red and Yellow LED's should turn off. Normal cutting or gouging can resume.</li> </ol>
The Thermal LED is lit.	<ol style="list-style-type: none"> <li>1. The machine's thermostat has tripped due to exceeded duty cycle limits. Do NOT turn the power off. Allow the machine to cool for 15 - 30 minutes and the thermostat will reset itself.</li> <li>2. The machine's air louvers or fans are obstructed such that air cannot flow to properly cool the machine. Remove any foreign material that may block air flow. Blow the machine out with a clean, dry air stream.</li> <li>3. The input voltage is not within <math>\pm 10\%</math> of rated values.</li> <li>4. Possible faulty Inverter board.</li> </ol>
When the trigger is pulled the Red and Yellow LED's are blinking together and the Green light is on.	<ol style="list-style-type: none"> <li>1. Check that nozzle and swirl ring are properly installed and they are the correct parts. <b>Note:</b> Swirl ring can only go in one way.</li> <li>2. Input voltage is too low and /or air pressure is set too high. Lower air pressure.</li> </ol>
When the trigger is pulled the Red LED is lit, air flows and no pilot arc occurs.	<ol style="list-style-type: none"> <li>1. Check that swirl ring is properly installed. <b>Note:</b> Swirl ring can only go in one way.</li> </ol>
The Red and Yellow LED's are blinking alternately.	<ol style="list-style-type: none"> <li>1. The torch safety circuit has been opened, when reconnected this condition should correctly reset automatically.</li> </ol>
When the trigger is pulled no air flows, Red LED is lit, no pilot arc. Then LED goes out.	<ol style="list-style-type: none"> <li>1. Check that the pressure gauge shows pressure. Air supply may not be connected or properly installed.</li> </ol>

TOMAHAWK 625 WIRING DIAGRAM

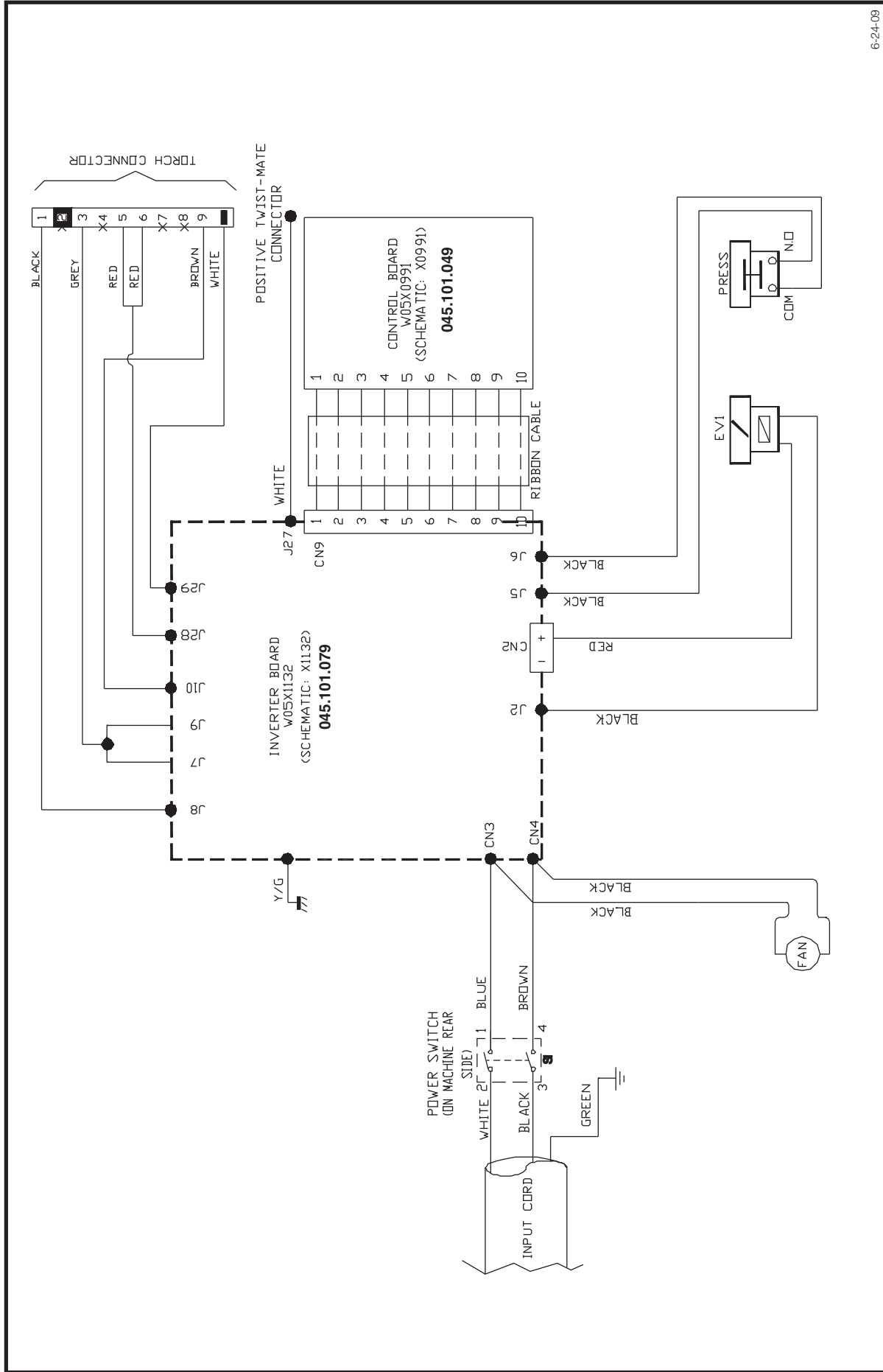

6-24-09

NOTE: This diagram is for reference only. It may not be accurate for all machines covered by this manual. The specific diagram for a particular code is pasted inside the machine on one of the enclosure panels. If the diagram is illegible, write to the Service Department for a replacement. Give the equipment code number.

# NOTES

---

			
<b>WARNING</b>	<ul style="list-style-type: none"> <li>Do not touch electrically live parts or electrode with skin or wet clothing.</li> <li>Insulate yourself from work and ground.</li> </ul>	<ul style="list-style-type: none"> <li>Keep flammable materials away.</li> </ul>	<ul style="list-style-type: none"> <li>Wear eye, ear and body protection.</li> </ul>
Spanish <b>AVISO DE PRECAUCION</b>	<ul style="list-style-type: none"> <li>No toque las partes o los electrodos bajo carga con la piel o ropa mojada.</li> <li>Aislese del trabajo y de la tierra.</li> </ul>	<ul style="list-style-type: none"> <li>Mantenga el material combustible fuera del área de trabajo.</li> </ul>	<ul style="list-style-type: none"> <li>Protéjase los ojos, los oídos y el cuerpo.</li> </ul>
French <b>ATTENTION</b>	<ul style="list-style-type: none"> <li>Ne laissez ni la peau ni des vêtements mouillés entrer en contact avec des pièces sous tension.</li> <li>Isoler vous du travail et de la terre.</li> </ul>	<ul style="list-style-type: none"> <li>Gardez à l'écart de tout matériel inflammable.</li> </ul>	<ul style="list-style-type: none"> <li>Protégez vos yeux, vos oreilles et votre corps.</li> </ul>
German <b>WARNUNG</b>	<ul style="list-style-type: none"> <li>Berühren Sie keine stromführenden Teile oder Elektroden mit Ihrem Körper oder feuchter Kleidung!</li> <li>Isolieren Sie sich von den Elektroden und dem Erdboden!</li> </ul>	<ul style="list-style-type: none"> <li>Entfernen Sie brennbares Material!</li> </ul>	<ul style="list-style-type: none"> <li>Tragen Sie Augen-, Ohren- und Körperschutz!</li> </ul>
Portuguese <b>ATENÇÃO</b>	<ul style="list-style-type: none"> <li>Não toque partes elétricas e electrodos com a pele ou roupa molhada.</li> <li>Isolar-se da peça e terra.</li> </ul>	<ul style="list-style-type: none"> <li>Mantenha inflamáveis bem guardados.</li> </ul>	<ul style="list-style-type: none"> <li>Use proteção para a vista, ouvido e corpo.</li> </ul>
Japanese <b>注意事項</b>	<ul style="list-style-type: none"> <li>● 通電中の電気部品、又は溶材にヒブやぬれた布で触れないこと。</li> <li>● 施工物やアースから身体が絶縁されている様にして下さい。</li> </ul>	<ul style="list-style-type: none"> <li>● 燃えやすいものの側での溶接作業は絶対にしてはなりません。</li> </ul>	<ul style="list-style-type: none"> <li>● 目、耳及び身体に保護具をして下さい。</li> </ul>
Chinese <b>警告</b>	<ul style="list-style-type: none"> <li>● 皮肤或湿衣物切勿接触带电部件及焊条。</li> <li>● 使你自已与地面和工件绝缘。</li> </ul>	<ul style="list-style-type: none"> <li>● 把一切易燃物品移离工作场所。</li> </ul>	<ul style="list-style-type: none"> <li>● 佩戴眼、耳及身体劳动保护用具。</li> </ul>
Korean <b>위험</b>	<ul style="list-style-type: none"> <li>● 전도체나 용접봉을 젖은 헝겍 또는 피부로 절대 접촉치 마십시오.</li> <li>● 모재와 접지를 접촉치 마십시오.</li> </ul>	<ul style="list-style-type: none"> <li>● 인화성 물질을 접근시키지 마십시오.</li> </ul>	<ul style="list-style-type: none"> <li>● 눈, 귀와 몸에 보호장구를 착용하십시오.</li> </ul>
Arabic <b>تحذير</b>	<ul style="list-style-type: none"> <li>● لا تلمس الاجزاء التي يسري فيها التيار الكهربائي أو الألكترود بجلد الجسم أو بالملابس المبللة بالماء.</li> <li>● ضع عازلا على جسمك خلال العمل.</li> </ul>	<ul style="list-style-type: none"> <li>● ضع المواد القابلة للاشتعال في مكان بعيد.</li> </ul>	<ul style="list-style-type: none"> <li>● ضع أدوات وملابس واقية على عينيك وأذنيك وجسمك.</li> </ul>

READ AND UNDERSTAND THE MANUFACTURER'S INSTRUCTION FOR THIS EQUIPMENT AND THE CONSUMABLES TO BE USED AND FOLLOW YOUR EMPLOYER'S SAFETY PRACTICES.

SE RECOMIENDA LEER Y ENTENDER LAS INSTRUCCIONES DEL FABRICANTE PARA EL USO DE ESTE EQUIPO Y LOS CONSUMIBLES QUE VA A UTILIZAR, SIGA LAS MEDIDAS DE SEGURIDAD DE SU SUPERVISOR.

LISEZ ET COMPRENEZ LES INSTRUCTIONS DU FABRICANT EN CE QUI REGARDE CET EQUIPMENT ET LES PRODUITS A ETRE EMPLOYES ET SUIVEZ LES PROCEDURES DE SECURITE DE VOTRE EMPLOYEUR.

LESEN SIE UND BEFOLGEN SIE DIE BETRIEBSANLEITUNG DER ANLAGE UND DEN ELEKTRODENEINSATZ DES HERSTELLERS. DIE UNFALLVERHÜTUNGSVORSCHRIFTEN DES ARBEITGEBERS SIND EBENFALLS ZU BEACHTEN.

			
<ul style="list-style-type: none"> <li>• Keep your head out of fumes.</li> <li>• Use ventilation or exhaust to remove fumes from breathing zone.</li> </ul>	<ul style="list-style-type: none"> <li>• Turn power off before servicing.</li> </ul>	<ul style="list-style-type: none"> <li>• Do not operate with panel open or guards off.</li> </ul>	<b>WARNING</b>
<ul style="list-style-type: none"> <li>• Los humos fuera de la zona de respiración.</li> <li>• Mantenga la cabeza fuera de los humos. Utilice ventilación o aspiración para gases.</li> </ul>	<ul style="list-style-type: none"> <li>• Desconectar el cable de alimentación de poder de la máquina antes de iniciar cualquier servicio.</li> </ul>	<ul style="list-style-type: none"> <li>• No operar con panel abierto o guardas quitadas.</li> </ul>	Spanish <b>AVISO DE PRECAUCION</b>
<ul style="list-style-type: none"> <li>• Gardez la tête à l'écart des fumées.</li> <li>• Utilisez un ventilateur ou un aspirateur pour ôter les fumées des zones de travail.</li> </ul>	<ul style="list-style-type: none"> <li>• Débranchez le courant avant l'entretien.</li> </ul>	<ul style="list-style-type: none"> <li>• N'opérez pas avec les panneaux ouverts ou avec les dispositifs de protection enlevés.</li> </ul>	French <b>ATTENTION</b>
<ul style="list-style-type: none"> <li>• Vermeiden Sie das Einatmen von Schweißrauch!</li> <li>• Sorgen Sie für gute Be- und Entlüftung des Arbeitsplatzes!</li> </ul>	<ul style="list-style-type: none"> <li>• Strom vor Wartungsarbeiten abschalten! (Netzstrom völlig öffnen; Maschine anhalten!)</li> </ul>	<ul style="list-style-type: none"> <li>• Anlage nie ohne Schutzgehäuse oder Innenschutzverkleidung in Betrieb setzen!</li> </ul>	German <b>WARNUNG</b>
<ul style="list-style-type: none"> <li>• Mantenha seu rosto da fumaça.</li> <li>• Use ventilação e exaustão para remover fumo da zona respiratória.</li> </ul>	<ul style="list-style-type: none"> <li>• Não opere com as tampas removidas.</li> <li>• Desligue a corrente antes de fazer serviço.</li> <li>• Não toque as partes elétricas nuas.</li> </ul>	<ul style="list-style-type: none"> <li>• Mantenha-se afastado das partes moventes.</li> <li>• Não opere com os painéis abertos ou guardas removidas.</li> </ul>	Portuguese <b>ATENÇÃO</b>
<ul style="list-style-type: none"> <li>● ヒュームから頭を離すようにして下さい。</li> <li>● 換気や排煙に十分留意して下さい。</li> </ul>	<ul style="list-style-type: none"> <li>● メンテナンス・サービスに取りかかる際には、まず電源スイッチを必ず切ってください。</li> </ul>	<ul style="list-style-type: none"> <li>● パネルやカバーを取り外したままで機械操作をしないで下さい。</li> </ul>	Japanese <b>注意事項</b>
<ul style="list-style-type: none"> <li>● 頭部遠離煙霧。</li> <li>● 在呼吸區使用通風或排風器除煙。</li> </ul>	<ul style="list-style-type: none"> <li>● 維修前切斷電源。</li> </ul>	<ul style="list-style-type: none"> <li>● 儀表板打開或沒有安全罩時不準作業。</li> </ul>	Chinese <b>警告</b>
<ul style="list-style-type: none"> <li>● 얼굴로부터 용접가스를 멀리하십시오.</li> <li>● 호흡지역으로부터 용접가스를 제거하기 위해 가스제거기나 통풍기를 사용하십시오.</li> </ul>	<ul style="list-style-type: none"> <li>● 보수전에 전원을 차단하십시오.</li> </ul>	<ul style="list-style-type: none"> <li>● 판넬이 열린 상태로 작동치 마십시오.</li> </ul>	Korean <b>위험</b>
<ul style="list-style-type: none"> <li>● ابعـد رأسك بعيداً عن الدخان.</li> <li>● استعمل التهوية أو جهاز ضغط الدخان للخارج لكي تبعد الدخان عن المنطقة التي تتنفس فيها.</li> </ul>	<ul style="list-style-type: none"> <li>● اقطع التيار الكهربائي قبل القيام بأية صيانة.</li> </ul>	<ul style="list-style-type: none"> <li>● لا تشغيل هذا الجهاز اذا كانت الاغطية الحديدية الواقية ليست عليه.</li> </ul>	Arabic <b>تحذير</b>

**LEIA E COMPREENDA AS INSTRUÇÕES DO FABRICANTE PARA ESTE EQUIPAMENTO E AS PARTES DE USO, E SIGA AS PRÁTICAS DE SEGURANÇA DO EMPREGADOR.**

使う機械や溶材のメーカーの指示書をよく読み、まず理解して下さい。そして貴社の安全規定に従って下さい。

請詳細閱讀並理解製造廠提供的說明以及應該使用的銀焊材料，並請遵守貴方的有関勞動保護規定。

이 제품에 동봉된 작업지침서를 숙지하시고 귀사의 작업자 안전수칙을 준수하시기 바랍니다.

اقرأ بتمعن وافهم تعليمات المصنع المنتج لهذه المعدات والمواد قبل استعمالها واتبع تعليمات الوقاية لصاحب العمل.



• World's Leader in Welding and Cutting Products •

• Sales and Service through Subsidiaries and Distributors Worldwide •

Cleveland, Ohio 44117-1199 U.S.A. TEL: 216.481.8100 FAX: 216.486.1751 WEB SITE: [www.lincolnelectric.com](http://www.lincolnelectric.com)