

www.wackergroup.com

0162560en	005
1107	

Roller

RD 12

RD 16



OPERATOR'S MANUAL

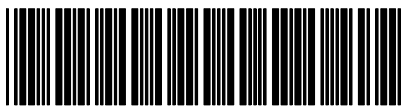

0 1 6 2 5 6 0 E N

1.	Foreword	6
2.	Safety Information	7
2.1	Operating Safety	8
2.2	Operator Safety while using Internal Combustion Engines	10
2.3	Service Safety	11
2.4	Label Locations—RD 12	13
2.5	Label Locations—RD 16	14
2.6	Safety and Operating Labels	15
3.	Operation	22
3.1	Operation and Service Locations—RD 16	22
3.2	Operation and Service Locations—RD 12	24
3.3	Control Panel—RD 16 IRH / RD 16-90 / RD 16-100	26
3.4	Control Panel—RD 12	28
3.5	Application	30
3.6	Roll Over Protection Structure (ROPS)	30
3.7	Foldable Roll Over Protection Structure (ROPS) (if equipped)	31
3.8	Rotating Beacon (if equipped)	33
3.9	Backup Alarm (if equipped)	33
3.10	Lighting Equipment (if equipped)	34
3.11	Seat Belt	35
3.12	Operator Presence System	36
3.13	Scraper Bars	37
3.14	Anti-Vandalism Protection and Machine Access	38
3.15	Articulation Joint Lockarm	39
3.16	Operation on Slopes	40
3.17	Recommended Fuel—RD 16	40
3.18	Recommended Fuel—RD 12	40
3.19	Before Starting	41
3.20	Starting—RD 16	42
3.21	Stopping/Parking—RD 16	44
3.22	Parking Brake Button—RD 16	45
3.23	Starting—RD 12	46
3.24	Stopping/Parking—RD 12	48
3.25	Parking Brake—RD 12	50
3.26	Parking Brake Adjustment—RD 12	51

3.27 Direction and Speed52
 3.28 Transmission53
 3.29 Vibration54
 3.30 Water Spray System55
 3.31 Battery Disconnect—RD 1656
 3.32 Auxiliary Battery Positive Terminal56
 3.33 Panel Indicator Lights—RD16 IRH / RD16-90 / RD16-10058
 3.34 Turn Signal/Hazard Lights (if equipped)—RD1660
 3.35 Panel Indicator Lights—RD1261
 3.36 Adding Ballast to Rear Drum—RD 1262

4. Maintenance 63

4.1 Honda Engine Maintenance Schedule—RD 1263
 4.2 Wacker Engine Maintenance Schedule—RD 1264
 4.3 Lombardini Engine Maintenance Schedule—RD 1665
 4.4 Roller Maintenance Schedule66
 4.5 Rear Frame Access67
 4.6 Battery68
 4.7 Fuel Filter—RD 1270
 4.8 Fuel Filter—RD 1671
 4.9 Priming the Fuel System—RD 1671
 4.10 Engine Oil and Filter—RD 1272
 4.11 Engine Oil and Filter—RD 1673
 4.12 Spark Plug—RD 1274
 4.13 Honda Engine Air Cleaner—RD 1275
 4.14 Wacker Engine Air Cleaner—RD 1276
 4.15 Lombardini Engine Air Cleaner—RD 1677
 4.16 Grease Fittings78
 4.17 Hydraulic System Cleanliness79
 4.18 Hydraulic Oil Requirements80
 4.19 Hydraulic Oil Level81
 4.20 Hydraulic Suction Strainer81
 4.21 Changing the Hydraulic Oil & Filter82
 4.22 Bleeding the Hydraulic System82
 4.23 Lifting the Machine83
 4.24 Tying Down and Transporting the Machine84
 4.25 Storage85
 4.26 Towing Bypass Valve—RD 1286
 4.27 Towing87
 4.28 Manually Releasing Parking Brake—RD 1689
 4.29 Troubleshooting90

5.	Technical Data	91
5.1	Engine	91
5.2	Roller	92
5.3	Lubrication	92
5.4	Dimensions—RD 12 / RD 16-90 / RD 16 IRH	93
5.5	Dimensions—RD 16-100	94
5.6	Sound Measurements	95
5.7	Measurements of Operator Exposure to Vibration	95
5.8	Hydraulic Schematic—RD 12/RD 12A	96
5.9	Hydraulic Schematic Components—RD 12/RD 12A	97
5.10	Hydraulic Schematic—RD 16	98
5.11	Hydraulic Schematic Components—RD 16	99
5.12	Electric Schematic—RD 12	100
5.13	Electrical Schematic Components—RD 12	101
5.14	Electrical Schematic—RD 12A	102
5.15	Electrical Schematic Components—RD 12A	103
5.16	Electrical Schematic—RD 16	104
5.17	Electrical Schematic Components—RD 16	106

CALIFORNIA

Proposition 65 Warning:



Engine exhaust, some of its constituents, and certain vehicle components, contain or emit chemicals known to the State of California to cause cancer and birth defects or other reproductive harm.

1. Foreword

This manual provides information and procedures to safely operate and maintain this Wacker model. For your own safety and protection from injury, carefully read, understand and observe the safety instructions described in this manual.

Keep this manual or a copy of it with the machine. If you lose this manual or need an additional copy, please contact Wacker Corporation. This machine is built with user safety in mind; however, it can present hazards if improperly operated and serviced. Follow operating instructions carefully! If you have questions about operating or servicing this equipment, please contact Wacker Corporation.

The information contained in this manual was based on machines in production at the time of publication. Wacker Corporation reserves the right to change any portion of this information without notice.

All rights, especially copying and distribution rights, are reserved.

Copyright 2007 by Wacker Corporation.

No part of this publication may be reproduced in any form or by any means, electronic or mechanical, including photocopying, without express written permission from Wacker Corporation.

Any type of reproduction or distribution not authorized by Wacker Corporation represents an infringement of valid copyrights and will be prosecuted. We expressly reserve the right to make technical modifications, even without due notice, which aim at improving our machines or their safety standards.

2 Safety Information

This manual contains DANGER, WARNING, CAUTION, *NOTICE* and NOTE callouts which must be followed to reduce the possibility of personal injury, damage to the equipment, or improper service.



This is the safety alert symbol. It is used to alert you to potential personal injury hazards. Obey all safety messages that follow this symbol to avoid possible injury or death.



DANGER

DANGER indicates a hazardous situation which, if not avoided, will result in death or serious injury.



WARNING

WARNING indicates a hazardous situation which, if not avoided, could result in death or serious injury.



CAUTION

CAUTION indicates a hazardous situation which, if not avoided, could result in minor or moderate injury.

NOTICE: Used without the safety alert symbol, **NOTICE** indicates a hazardous situation which, if not avoided, could result in property damage.

Note: *Contains additional information important to a procedure.*

2.1 Operating Safety

Notice: State Health Safety Codes and Public Resources Codes specify that in certain locations spark arresters be used on internal combustion engines that use hydrocarbon fuels. A spark arrester is a device designed to prevent accidental discharge of sparks or flames from the engine exhaust. Spark arresters are qualified and rated by the United States Forest Service for this purpose.

In order to comply with local laws regarding spark arresters, consult the engine distributor or the local Health and Safety Administrator.



Familiarity and proper training are required for the safe operation of the machine. Machines operated improperly or by untrained personnel can be dangerous. Read the operating instructions contained in both this manual and the Engine Manual and familiarize yourself with the location and proper use of all controls. Inexperienced operators should receive instruction from someone familiar with the machine before being allowed to operate it.

- 2.1.1 DO NOT drive over curbs or other uneven objects that will result in the machine and operator being shaken.
- 2.1.2 DO NOT attempt to start the machine when standing alongside it. Only start the engine when seated in the driver's seat and with the forward/reverse control in the neutral position.
- 2.1.3 NEVER allow anyone to operate this equipment without proper training. People operating this equipment must be familiar with the risks and hazards associated with it.
- 2.1.4 NEVER touch the engine or muffler while the engine is on or immediately after it has been turned off. These areas get hot and may cause burns.
- 2.1.5 NEVER use accessories or attachments that are not recommended by Wacker. Damage to equipment and injury to the user may result.
- 2.1.6 NEVER leave the machine running unattended.
- 2.1.7 NEVER operate the machine with the fuel cap loose or missing.
- 2.1.8 NEVER carry passengers on the machine. Danger of crushing—keep clear of the articulated steering joint between the front and rear frames.
- 2.1.9 NEVER use or attempt to repair damaged safety belts or ROPS. Replace only with Wacker spare parts.
- 2.1.10 ALWAYS disengage and stow the locking bar for the articulated steering joint before operating the machine. The machine cannot be steered when the locking bar is engaged.
- 2.1.11 ALWAYS check that all controls are functioning properly immediately after start-up! DO NOT operate the machine unless all controls operate correctly.

- 2.1.12 ALWAYS remain aware of changing positions and the movement of other equipment and personnel on the job site.
- 2.1.13 ALWAYS remain seated and wear the seat belt at all times while operating the machine.
- 2.1.14 ALWAYS remain aware of changing surface conditions and use extra care when operating over uneven ground, on hills, or over soft or coarse material. The machine could shift or slide unexpectedly.
- 2.1.15 ALWAYS use caution when operating the machine near the edges of pits, trenches or platforms. Check to be sure that ground surface is stable enough to support the weight of the machine with operator and that there is no danger of the roller sliding, falling or tipping.
- 2.1.16 ALWAYS wear protective clothing appropriate to the job site when operating the machine.
- 2.1.17 ALWAYS keep hands, feet, and loose clothing away from moving parts of the machine.
- 2.1.18 ALWAYS read, understand, and follow procedures in the Operator's Manual before attempting to operate the machine.
- 2.1.19 ALWAYS store the machine properly when it is not being used. The machine should be stored in a clean, dry location out of the reach of children.
- 2.1.20 ALWAYS operate the machine with all safety devices and guards in place and in working order.
- 2.1.21 ALWAYS be sure that all other persons are at a safe distance from the machine. Stop the machine if people step into the working area of the machine.

2.2 Operator Safety while using Internal Combustion Engines



DANGER

Internal combustion engines present special hazards during operation and fueling. Read and follow the warning instructions in the engine Owner's Manual and the safety guidelines below. Failure to follow the warnings and safety standards could result in severe injury or death.

- 2.2.1 DO NOT smoke while operating the machine.
- 2.2.2 DO NOT smoke when refueling the engine.
- 2.2.3 DO NOT refuel a hot or running engine.
- 2.2.4 DO NOT refuel the engine near an open flame.
- 2.2.5 DO NOT spill fuel when refueling the engine.
- 2.2.6 DO NOT run the engine near open flames.
- 2.2.7 DO NOT run the machine indoors or in an enclosed area such as a deep trench unless adequate ventilation, through such items as exhaust fans or hoses, is provided. Exhaust gas from the engine contains poisonous carbon monoxide gas; exposure to carbon monoxide can cause loss of consciousness and may lead to death.
- 2.2.8 ALWAYS refill the fuel tank in a well-ventilated area.
- 2.2.9 ALWAYS replace the fuel tank cap after refueling.
- 2.2.10 ALWAYS keep the area around a hot exhaust pipe free of debris to reduce the chance of an accidental fire.
- 2.2.11 ALWAYS check the fuel lines and the fuel tank for leaks and cracks before starting the engine. Do not run the machine if fuel leaks are present or the fuel lines are loose.

2.3 Service Safety

**WARNING**

A poorly maintained machine can become a safety hazard! In order for the machine to operate safely and properly over a long period of time, periodic maintenance and occasional repairs are necessary.

- 2.3.1 Some service procedures require that the machine's battery be disconnected. To reduce the risk of personal injury, read and understand the service procedures before performing any service to the machine.
- 2.3.2 All adjustments and repairs **MUST** be completed before operation. **NEVER** operate the machine with a known problem or deficiency! All repairs and adjustments should be completed by a qualified technician.
- 2.3.3 **DO NOT** attempt to clean or service the machine while it is running. Rotating parts can cause severe injury.
- 2.3.4 RD 12 only - **DO NOT** crank a flooded engine with the spark plug removed on gasoline-powered engines. Fuel trapped in the cylinder will squirt out the spark plug opening.
- 2.3.5 RD 12 only - **DO NOT** test for spark on gasoline-powered engines if the engine is flooded or the smell of gasoline is present. A stray spark could ignite the fumes.
- 2.3.6 **DO NOT** use gasoline or other types of fuels or flammable solvents to clean parts, especially in enclosed areas. Fumes from fuels and solvents can become explosive.
- 2.3.7 **DO NOT** modify the machine without the express written approval of the manufacturer.
- 2.3.8 RD 16 only - **DO NOT** remove the radiator cap when the engine is running or hot. The radiator fluid is hot and under pressure and may cause severe burns!
- 2.3.9 **DO NOT** stand under the machine while it is being hoisted or moved.
- 2.3.10 **DO NOT** get onto the machine while it is being hoisted or moved.
- 2.3.11 **DO NOT** use the machine as a ladder. Use safe ladders and platforms designed for this purpose.
- 2.3.12 **DO NOT** modify, weld, or drill safety frames (ROPS) fitted as original equipment. **DO NOT** loosen or remove bolts. **DO NOT** weld, drill or modify a broken safety frame.

- 2.3.13 DO NOT open the hydraulic lines or loosen the hydraulic connections while the engine is running! Before dismantling the hydraulic connectors or hoses, ensure that all pressure has been bled from the circuit. Hydraulic fluid under pressure can penetrate the skin, cause burns, blind, or create other potentially dangerous hazards. Set all controls in neutral, turn engine off, and allow the fluids to cool before loosening hydraulic fittings or attaching test gauges.
- 2.3.14 ALWAYS check all external fasteners at regular intervals.
- 2.3.15 ALWAYS keep the area around the muffler free of debris such as leaves, paper, cartons, etc. A hot muffler could ignite the debris and start a fire.
- 2.3.16 ALWAYS replace worn or damaged components with spare parts designed and recommended by Wacker Corporation.
- 2.3.17 ALWAYS disconnect the spark plug on machines equipped with gasoline engines, before servicing, to avoid accidental start-up.
- 2.3.18 ALWAYS keep the machine clean and labels legible. Replace all missing and hard-to-read labels. Labels provide important operating instructions and warn of dangers and hazards.
- 2.3.19 ALWAYS do periodic maintenance as recommended in the Operator's Manual.
- 2.3.20 ALWAYS turn the engine off before performing maintenance or making repairs.
- 2.3.21 ALWAYS keep hands, feet and loose clothing away from moving parts.
- 2.3.22 ALWAYS make sure slings, chains, hooks, ramps, jacks and other types of lifting devices are attached securely and have enough weight-bearing capacity to lift or hold the machine safely. Always remain aware of the location of other people in the area when lifting the machine.
- 2.3.23 ALWAYS make sure hose connections have been reconnected back to the correct fitting. Failure to do so may result in damage to the machine and/or injury to person on or near the machine.
- 2.3.24 ALWAYS secure the articulated steering joint using the locking bar before lifting, jacking, and servicing the machine. The machine halves could swing together unexpectedly and cause a serious injury.
- 2.3.25 ALWAYS lock the lifting cylinders in the open position when the seat pedestal is raised.
- 2.3.26 Before you start the machine, ensure that all tools have been removed from the machine and that replacement parts and adjusters are firmly tightened.
- 2.3.27 Fluid leaks from small holes are often practically invisible. DO NOT use your bare hands to check for leaks. Check for leaks using a piece of cardboard or wood.

2.4 Label Locations—RD 12

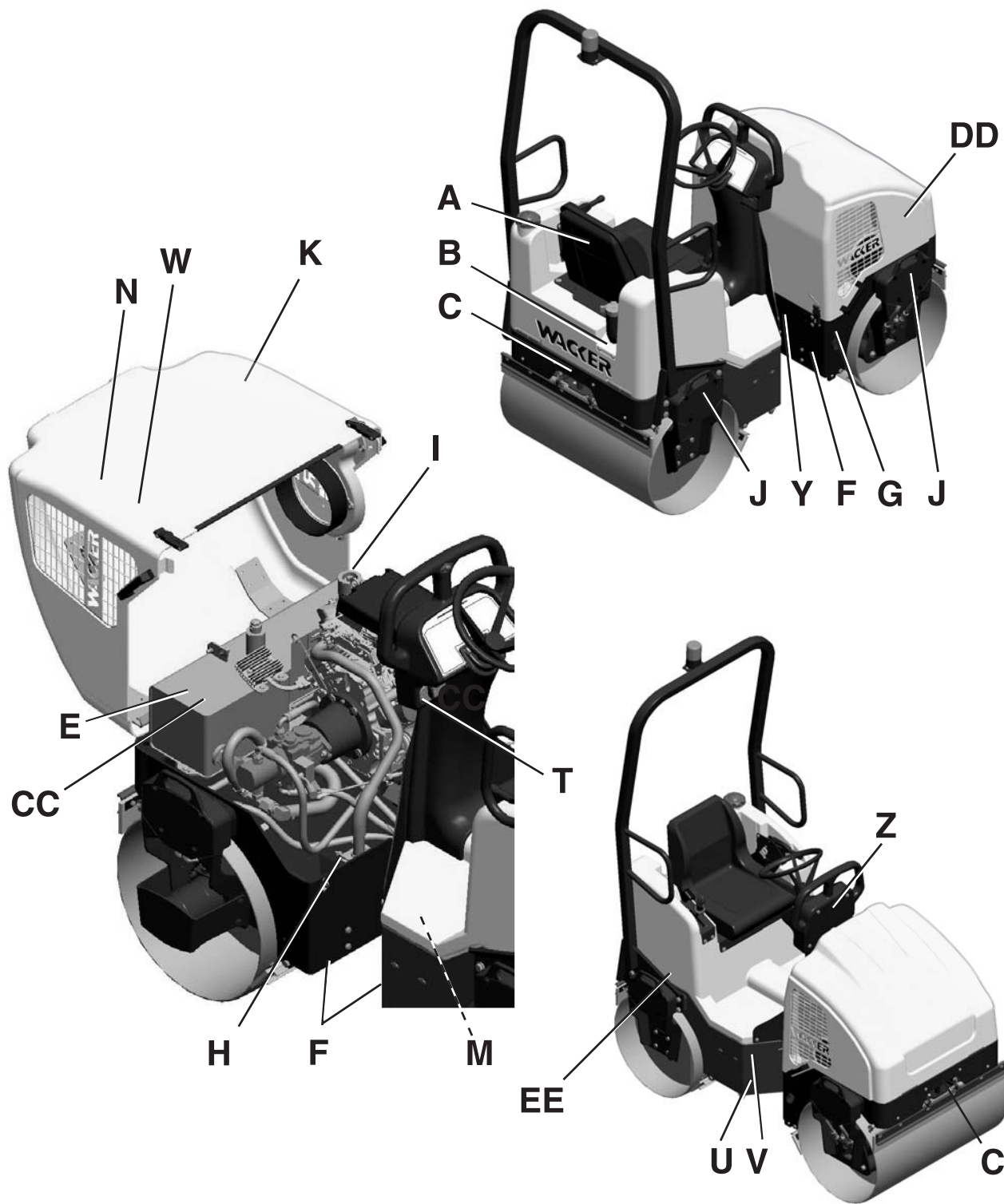

wc_gr002988

2.5 Label Locations—RD 16

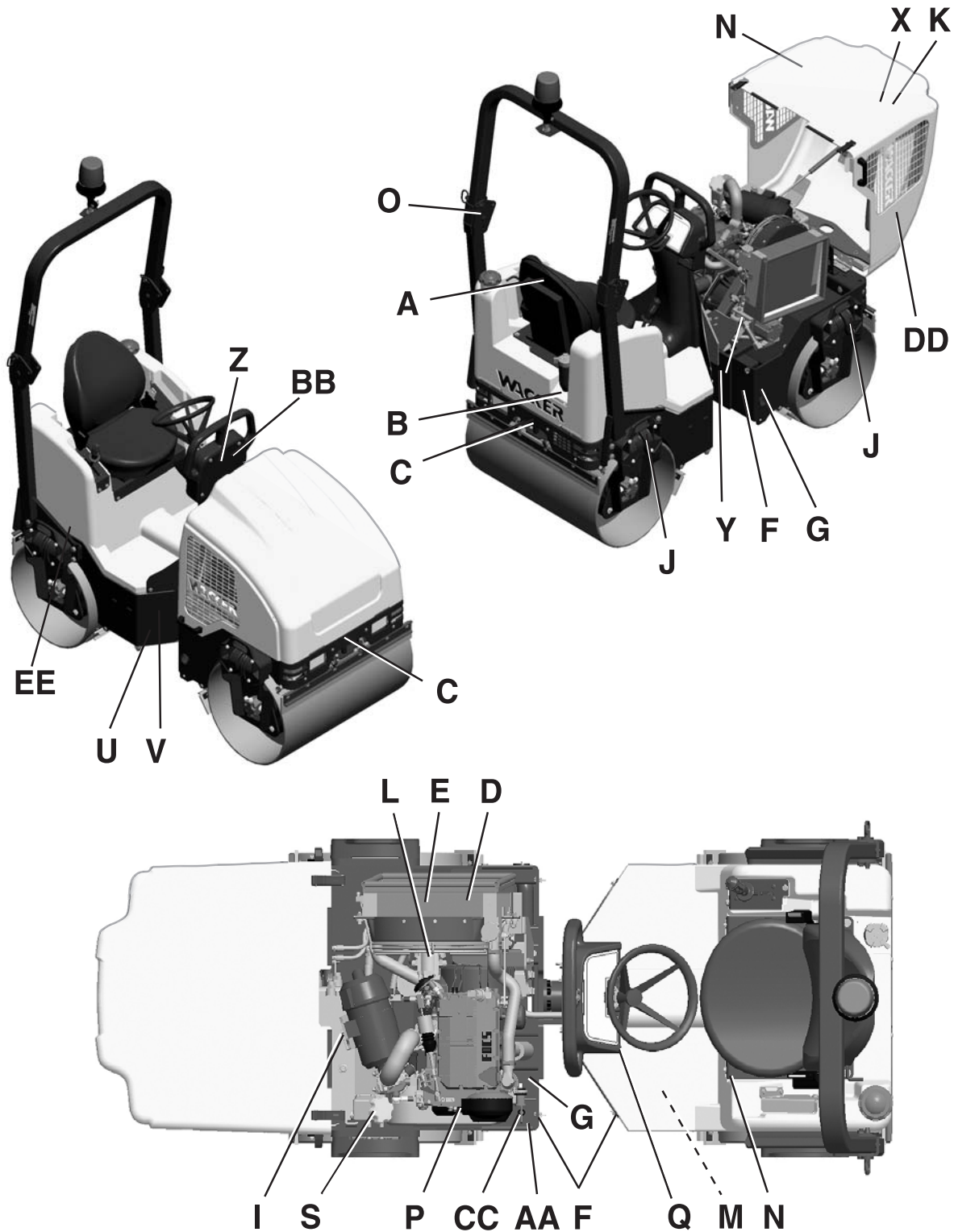







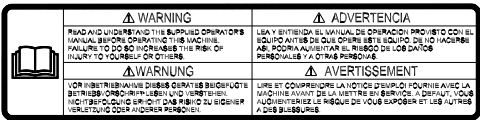
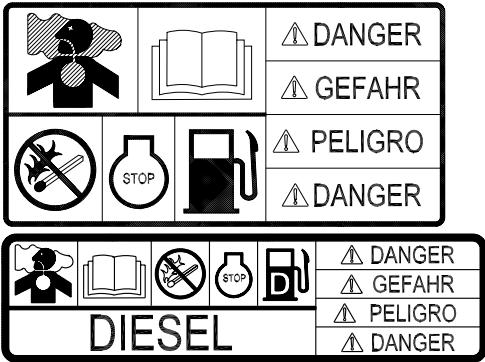
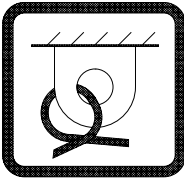
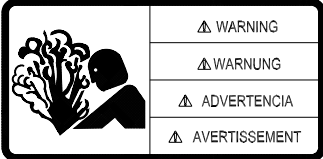
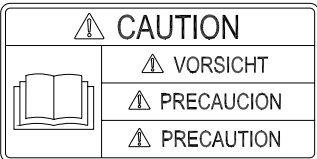

wc_gr002973

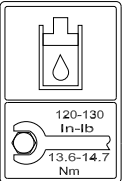

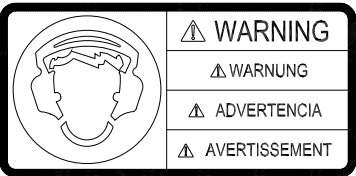
2.6 Safety and Operating Labels

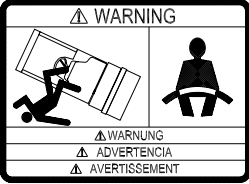

Wacker machines use international pictorial labels where needed. These labels are described below:

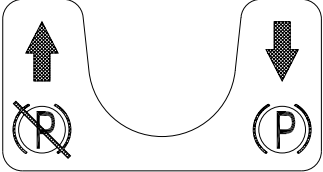
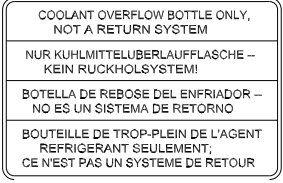
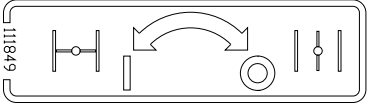
Ref.	Label	Meaning
A		<p>WARNING! Read and understand the supplied Operator's Manual before operating the machine. Failure to do so increases the risk of injury to yourself or others.</p>
B		<p>DANGER! Engines emit carbon monoxide; operate only in well-ventilated area. Read the Operator's Manual. No sparks, flames, or burning objects near the machine. Shut off the engine before refueling.</p>
C		<p>Tie-down point.</p>
D	 <p>110164</p>	<p>WARNING! Pressurized contents. Do not open when hot!</p>
E		<p>CAUTION! Read and understand the supplied Operator's Manuals before operating this machine. Failure to do so increases the risk of injury to yourself or others.</p>

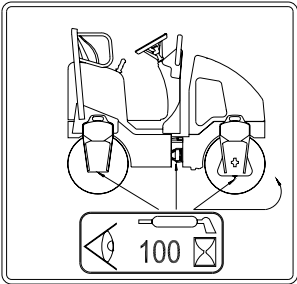
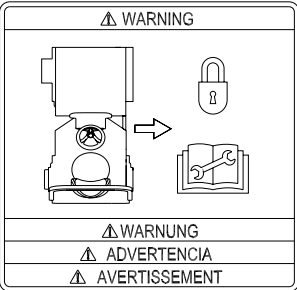
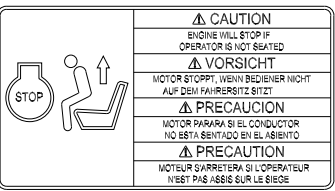
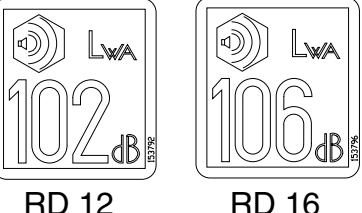
Ref.	Label	Meaning
F		<p>WARNING! Pinch point.</p>
G		<p>WARNING! Hot surface!</p>
H		<p>WARNING! Hot surface!</p>
I		<p>Hydraulic oil reservoir fill tube. Torque nuts to 13.6-14.7 Nm (120-130 in.lbs.) maximum.</p>
J		<p>CAUTION! Lifting point.</p>
K		<p>WARNING! To prevent hearing loss, wear hearing protection when operating this machine.</p>
L		<p>WARNING! Pinching hazard. Rotating machinery.</p>

Ref.	Label	Meaning
M		<p>WARNING! Disconnect battery before servicing. Read repair manual for instructions. Battery contains caustic acid and potentially explosive hydrogen gas.</p>
N		<p>WARNING! Always wear seat belt when operating roller.</p>
O		<p>WARNING! Avoid crushing area.</p>
P		<p>WARNING! Hand injury if entangled in moving belt.</p>
Q		<p>Parking brake is disengaged. Parking brake is engaged.</p>
S		<p>Coolant overflow bottle only, not a return system.</p>
T		<p>Choke: 0 = Open I = Closed</p>

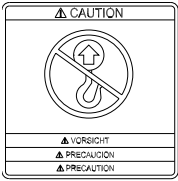
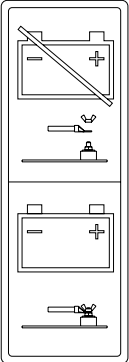
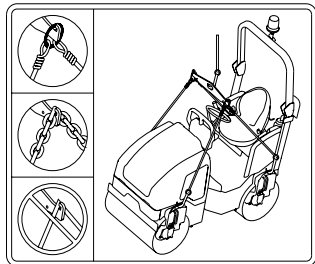
Ref.	Label	Meaning
U		<p>Grease points: Inspect and lubricate every 100 hours of operation.</p>
V		<p>WARNING!</p> <p>Avoid crushing area. Articulated steering joint locking location. Lock the articulated steering joint before servicing the machine. Read Repair Manual.</p>
W		<p>RD 12 only—Engine will stop without operator seated.</p>
X		<p>Guaranteed sound power level in dB(A).</p>
Y		<p>A nameplate listing the model number, item number, revision number, and serial number is attached to each unit. Please record the information found on this plate so it will be available should the nameplate become lost or damaged. When ordering parts or requesting service information, you will always be asked to specify the model number, item number, revision number, and serial number of the unit.</p>

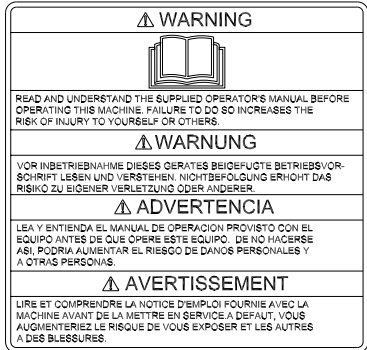
Ref.	Label	Meaning
Z		No lift point.
AA		RD 16 only. WARNING! Disconnect battery before servicing.
BB		RD 16 only. Lifting of machine to be done with spreader bar only!
CC		CAUTION! Electric shock hazard at auxiliary battery positive terminal. Never touch this terminal and a metal portion of the machine simultaneously.
DD		WARNING! Read and understand the supplied Operator's Manual before operating the machine. Failure to do so increases the risk of injury to yourself or others.

Ref.	Label	Meaning
EE	 <p>The label is rectangular with a black border. On the left side, it contains the text: "WATER TANK", "WASSERTANK", "TANQUE PARA AGUA", and "RESERVOIR D'EAU" stacked vertically. On the right side, there is a pictogram of a water tank with a downward-pointing arrow below it. A small vertical number "1728" is located on the right edge of the pictogram.</p>	Water tank

Notes:

3. Operation

3.1 Operation and Service Locations—RD 16

See Graphic: *wc_gr002947*

Ref.	Description	Ref.	Description
1	Air cleaner	22	Water tank fill cap
2	Articulated joint	23	Lockarm
3	Hand holds	24	Operator's platform
4	Control panel	25	Engine oil filter
5	Dipstick	27	Rear drum
6	Drain hose—hydraulic tank	28	Scraper bar (4 places)
7	Drive motor (2)	29	Sightglass—hydraulic tank
8	Drive pump	30	Sprinkler tube (2)
9	Engine hood	31	Steering wheel
10	Vibration control button	32	Steering cylinder (under floor panel)
11	Exciter motor (2)	33	Tiedown (2 places)
12	Exciter/Steering pump	34	Rotating beacon
13	Hydraulic filter—return line	35	Battery (under floor panel)
14	Hydraulic strainer—suction line	36	Hydraulic suction line
15	Forward/Reverse control	37	Grease fitting—exciter (4 places)
16	Front drum	38	Lifting eye (4 places)
17	Fuel tank fill cap	39	ROPS
18	Fuel filter	40	Adjustable seat with seat belt
19	Grease fittings—articulated joint (4 places)	41	Water drain
20	Hydraulic tank fill port	42	Parking brake button
21	Hydraulic manifold block	45	Auxiliary battery positive terminal

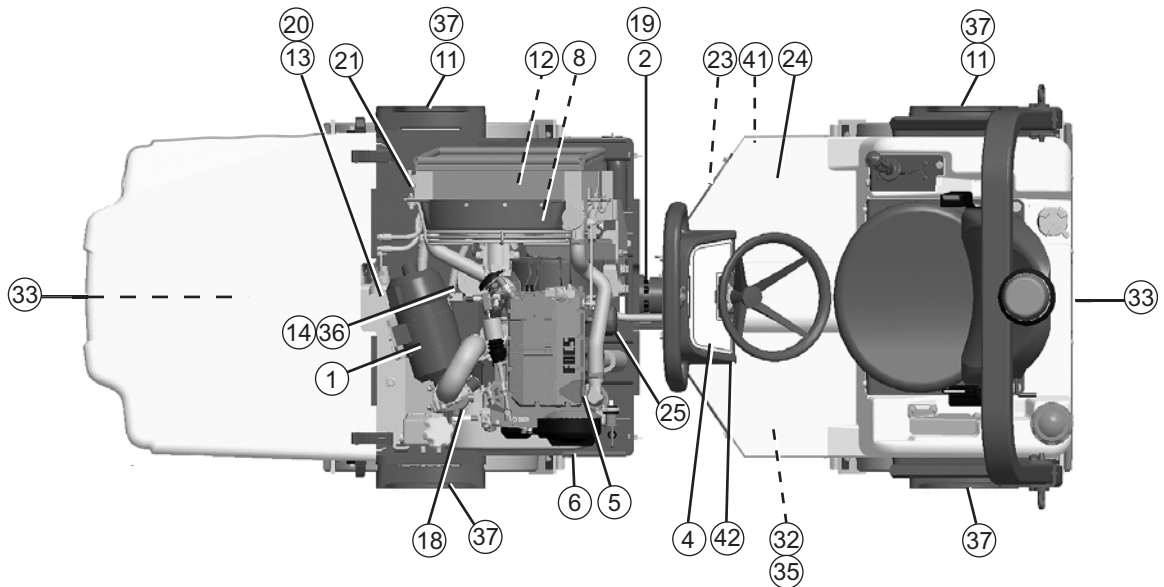
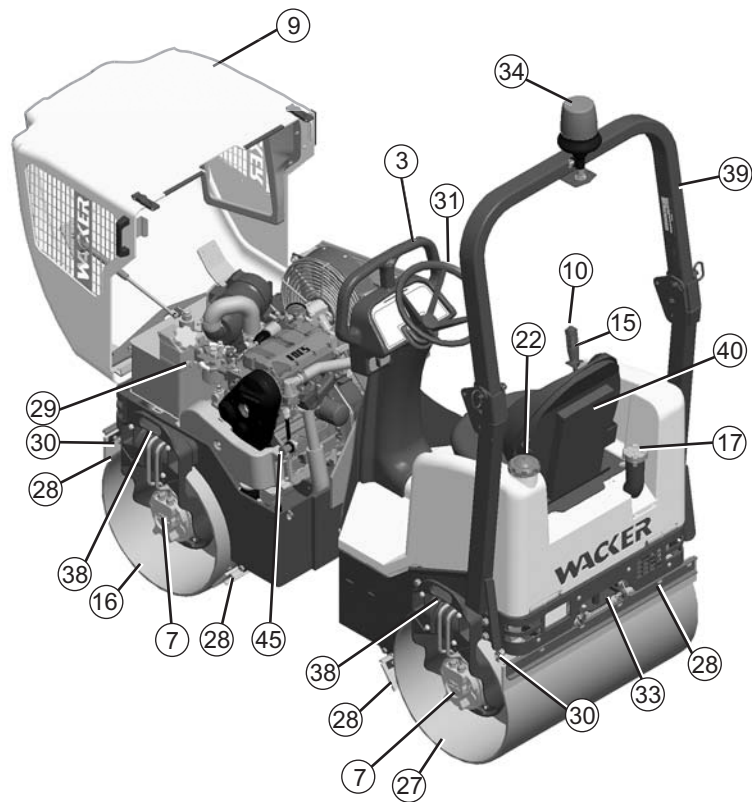

wc_gr002947

3.2 Operation and Service Locations—RD 12

See Graphic: wc_gr002946

Ref.	Description	Ref.	Description
1	Air cleaner	24	Operator's platform
2	Articulated joint	25	Engine oil filter
3	Hand holds	26	Rear drum fill/drain plug
4	Control panel	27	Rear drum—static
5	Dipstick	28	Scraper bar (4 places)
6	Drain hose—hydraulic tank	29	Sightglass—hydraulic tank
7	Drive motor	30	Sprinkler tube (2)
8	Drive pump	31	Steering wheel
9	Engine hood	32	Steering cylinder (under floor panel)
10	Vibration control button	33	Tiedown (2 places)
11	Exciter motor	34	Beacon light (optional)
12	Exciter/Steering pump	35	Battery (under floor panel)
13	Hydraulic filter—return line	36	Hydraulic suction line
14	Hydraulic strainer—suction line	37	Grease fitting—exciter (2 places)
15	Forward / Reverse control	38	Lifting eye (4 places)
16	Front drum—vibratory	39	ROPS
17	Fuel tank fill cap	40	Seat with seatbelt
18	Fuel filter	41	Water drain
19	Grease fittings—articulated joint (4 places)	42	Parking brake
20	Hydraulic tank fill port	43	Tow valve
21	Hydraulic manifold block	44	Choke lever
22	Water tank fill cap	45	Auxiliary battery positive terminal
23	Lockarm	-	---

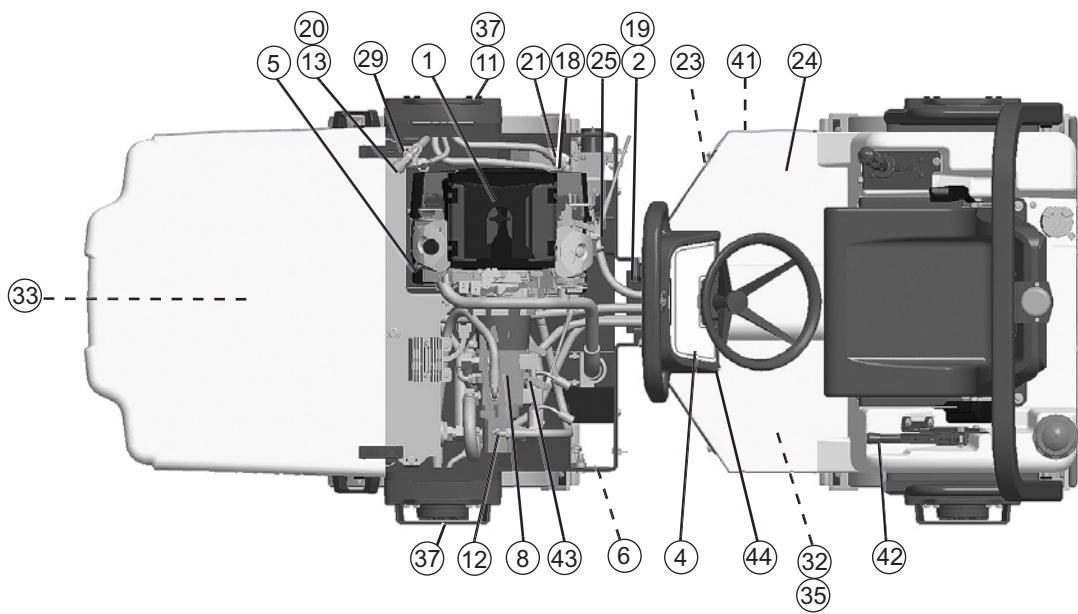
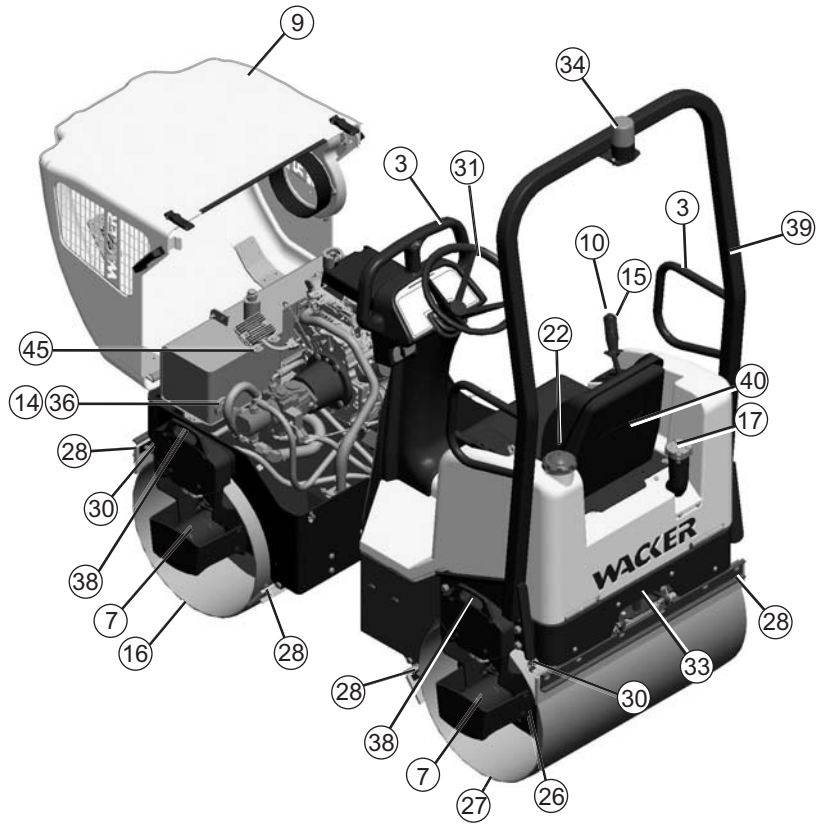

wc_gr002946

3.3 Control Panel—RD 16 IRH / RD 16-90 / RD 16-100

See Graphic: wc_gr004113

Ref.	Description	Ref.	Description
46	Turn signal switch—LEFT and RIGHT (RD 16IRH only)	56	Low fuel indicator
47	Hour meter	57	Air filter indicator
48	Engine coolant temperature indicator	58	Glow plug indicator
49	Low oil pressure indicator	59	Parking brake ON indicator
50	Vibration ON indicator	60	Battery indicator
51	Hazard lights switch—ON and OFF	61	Water spray switch—ON and OFF
52	Lights switch—multi-position (RD 16IRH only)	62	Water spray dial
53	Turn signal indicator (RD 16IRH only)	63	Vibration switch —BOTH DRUMS and FRONT DRUM ONLY
54	Throttle switch—HIGH and LOW	64	Horn
55	Ignition switch	-	---

RD 16 IRH

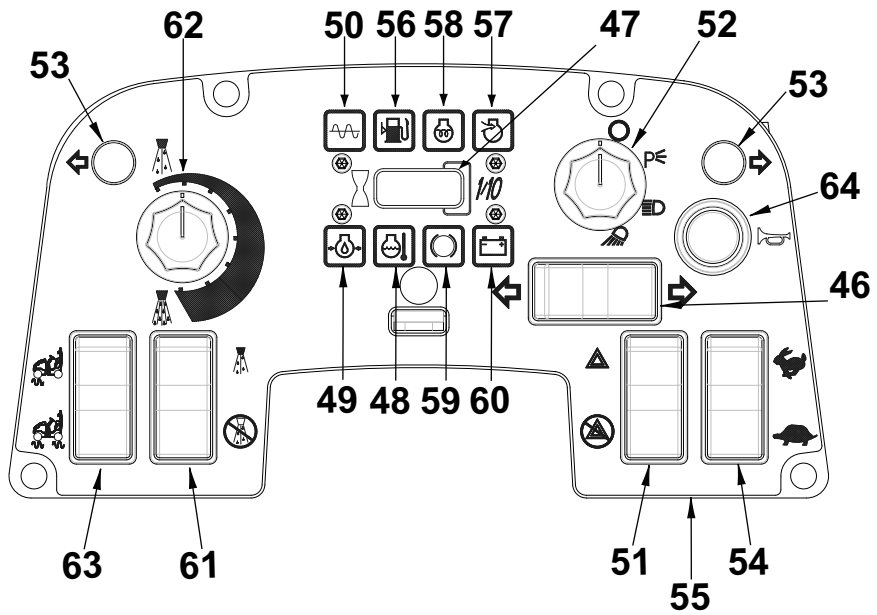

RD 16-90
RD 16-100

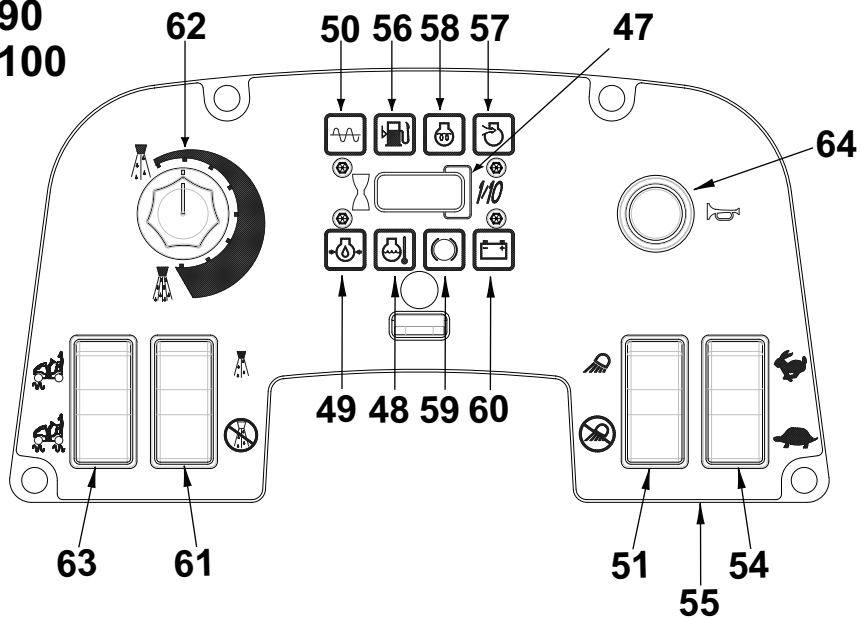

wc_gr004113

3.4 Control Panel—RD 12

See Graphic: *wc_gr004114*

Ref.	Description	Ref.	Description
47	Hour meter	55	Ignition switch
50	Vibration ON indicator	56	Low fuel indicator
53	Lights switch - ON and OFF (if equipped)	61	Water spray switch - ON and OFF
54	Throttle switch - HIGH and LOW	62	Water spray dial

RD 12

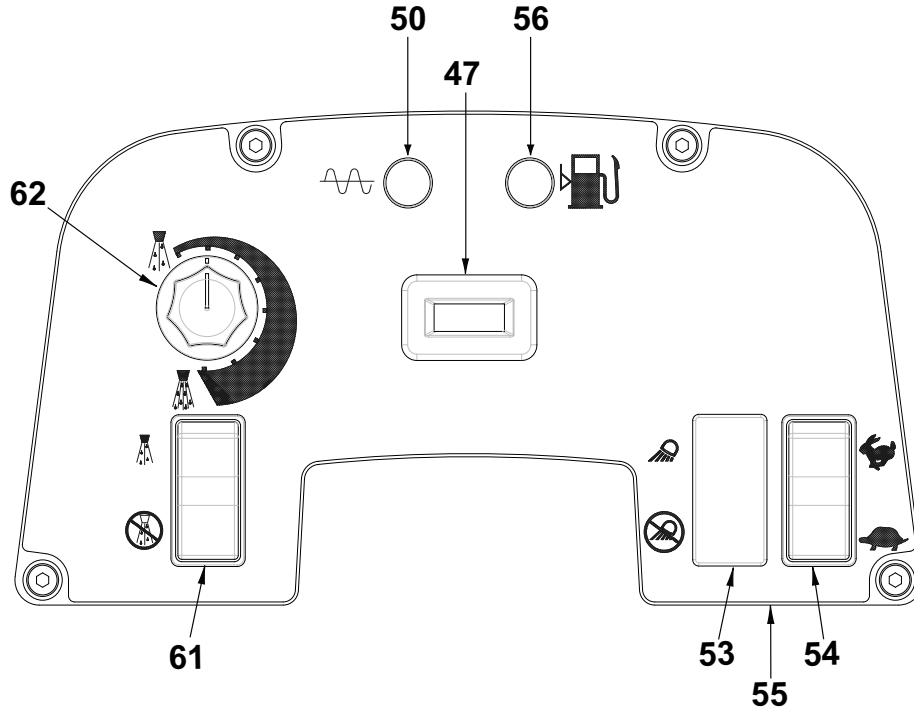

wc_gr004114

3.5 Application

This machine is designed as a lightweight roller to be used in the compaction of sublayers and finish layers of asphalt on roads, driveways, parking lots, and other types of asphalt-covered surfaces. Do not use this machine for any other purpose.

3.6 Roll Over Protection Structure (ROPS)

The machine is equipped with a Roll Over Protection Structure (ROPS). The machine is normally delivered to the customer with the ROPS folded forward to facilitate transport.



WARNING

Do not use the machine without the ROPS in place. The ROPS is designed to protect the operator in a rollover accident.

Before using the machine, position the ROPS in the fully upright position as follows:

- 3.6.1 Support the ROPS using a crane and suitable rigging capable of supporting 43 kg (95 lbs.).

NOTICE: Do not use the ROPS to lift the machine.

- 3.6.2 Remove the shipping strap from both sides of the frame. Save the washers.
- 3.6.3 Loosen the bottom mounting bolt on both sides.
- 3.6.4 Rotate the ROPS into the upright position.
- 3.6.5 Secure the ROPS to the frame using the saved washers and the supplied bolts. Torque hardware to 106 Nm (78 ft.lbs.).

Each month, check the torque on all of the screws holding the ROPS in place. Check that the ROPS frame is not rusty, cracked, broken, or damaged in any way.

Change the seat belts every 3 years, or any time they have been subjected to accident-level loads.

If the ROPS has been removed from the machine, it must be reinstalled before the machine is used. When reinstalling the ROPS, use the original nuts and bolts and tighten the bolts to the specified torques.

Do not weld or drill into the ROPS. Drilling or welding on the ROPS will nullify the ROPS certification.

3.7 Foldable Roll Over Protection Structure (ROPS) (if equipped)

See Graphic: *wc_gr002957*

The machine is equipped with a Roll Over Protection Structure (ROPS). The machine is normally delivered to the customer with the ROPS folded forward to facilitate transport.



WARNING

Do not use the machine without the ROPS in place. The ROPS is designed to protect the operator in a rollover accident.

Before using the machine, position the ROPS in the fully upright position as follows:

- 3.7.1 Support the upper mass ROPS using a crane and suitable rigging capable of supporting 19 kg (42 lbs.).

NOTICE: Do not use the ROPS to lift the machine.

- 3.7.2 Remove the safety pin **(a)** and pull out the locking pin **(b)**. Do so on both sides.
- 3.7.3 Lift the ROPS into the upright position.
- 3.7.4 Insert the locking pins and secure them with the safety pins.



WARNING

Be aware of pinch points when lowering and raising the ROPS.

To lower the ROPS:

- 3.7.5 Support the upper mass of the ROPS using a crane and suitable rigging capable of supporting 19 kg (42 lbs.).
- 3.7.6 Remove the safety pin **(a)** and pull out the locking pin **(b)**. Do so on both sides.
- 3.7.7 Gently lower the upper mass.

Note: *When lowering ROPS, do not allow the upper frame to fall into the lower position. Allowing the upper mass to slam will weaken the ROPS system and ultimately compromise its integrity and protection.*

- 3.7.8 Insert the pins in the ROPS in the lower hole setting through the upper mass to secure it for transport.

Each month, check the torque on all of the screws holding the ROPS in place. Check that the ROPS frame is not rusty, cracked, broken, or damaged in any way.

Keep the ROPS in the extended (upright) position when using the roller, and always use the seat belts provided.

Change the seat belts every 3 years, or any time they have been subjected to accident-level loads.

If the ROPS has been removed from the machine, it must be reinstalled before the machine is used. When reinstalling the ROPS, use the original nuts and bolts and tighten the bolts to the specified torques.

Do not weld or drill into the ROPS. Drilling or welding on the ROPS will nullify the ROPS certification.

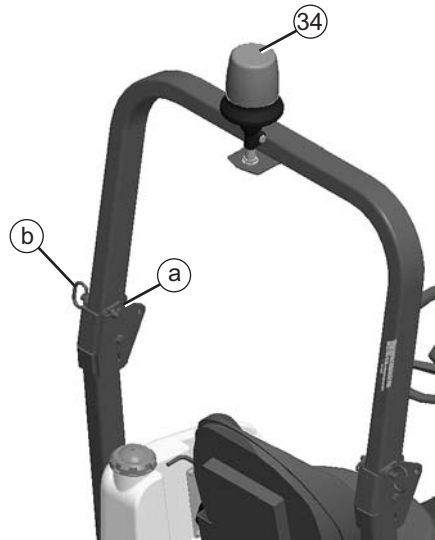

wc_gr002957

3.8 Rotating Beacon (if equipped)

See Graphic: *wc_gr002957*

The rotating beacon **(34)** powers up when the ignition switch is turned to the ON position.

RD 12 - The beacon flashes when powered up.

RD 16 - The beacon illuminates and rotates when powered up.

To install the beacon (RD 16 only):

3.8.1 Slide the rotating beacon onto the light staff.

3.8.2 Tighten the wing nut on the base of the light.

3.9 Backup Alarm (if equipped)

The backup alarm is located on the rear of the machine.

Start the engine and move the forward/reverse control to the reverse position. The backup alarm should sound immediately. The backup alarm will continue to sound until the forward/reverse control is moved to the neutral position or to the forward position.

If the backup alarm does not sound, make the necessary repairs before using the roller.

3.10 Lighting Equipment (if equipped)

See Graphic: wc_gr004115



When working in the dark or in bad visibility, use all the lights available. Replace broken bulbs immediately. Only replace bulbs when the machine is turned off. Remember that your safety and the safety of others depends on your care and attention when operating this machine.

Parking lights (A)

On the RD 16 IRH only, this switch position turns on the parking lights.

Lights on (B)

On the RD 16 IRH, this switch position turns on the rear work lights.

On the RD 12 and RD 16, this switch position turns on the front and rear lights.

Front road lights (C)

On the RD 16 IRH only, this switch position turns on the front lights.

Lights off (D)

This switch position turns off all the lights.

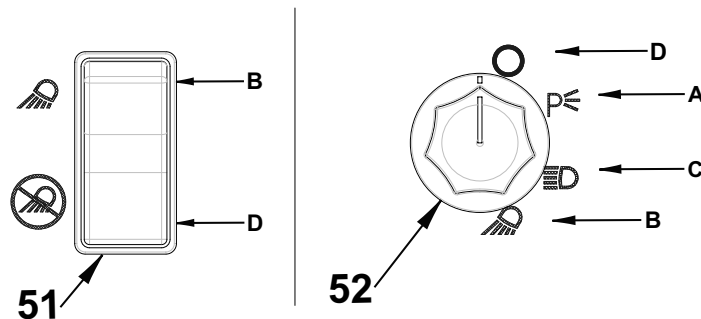

wc_gr004115

3.11 Seat Belt

See Graphic: *wc_gr002238*

Pull seat belt **(c)** out of the retractor in a continuous motion.

Fasten seat belt catch **(b)** into buckle **(a)**. Make sure that the seat belt is placed low across the lap of the operator.

The retractor will adjust the belt length and the retractor will lock in place.

Push the release button **(d)** on the buckle in order to release the seat belt. The seat belt will automatically retract into the retractor.

Replace the seat belt every three years.

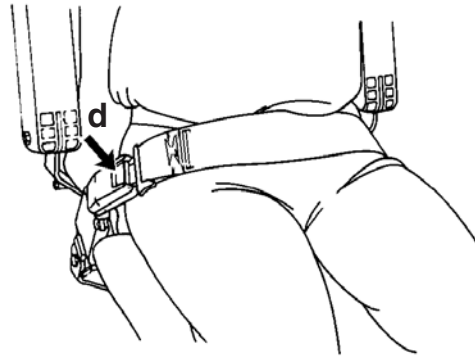
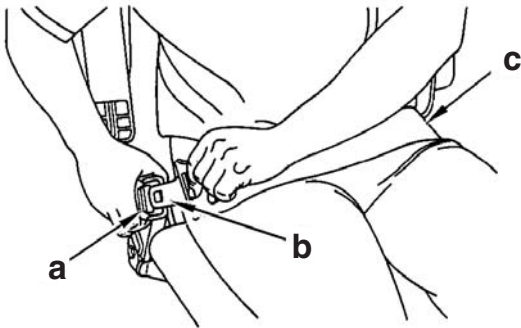

wc_gr002238

3.12 Operator Presence System

See Graphic: *wc_gr002962*

The machine is equipped with an “operator presence system”. This system is part of the driver's seat and senses the weight of an operator in the seat. If the operator is not sitting in the driver's seat, the roller will NOT drive. On the RD 12, if the operator leaves the driver's seat and the forward/reverse control is not in neutral, the engine will be turned off. On the RD 16, if the operator leaves the driver's seat, the brakes will activate. When the operator sits down again, the forward/reverse control must be placed in the neutral position before the roller can be driven or the vibration can be started.

Note: *A one-half second delay keeps the system from tripping when the roller passes over a bump.*

If the roller is supplied with an adjustable seat, it can be adjusted as follows:

- Knob **(a)** for adjusting the seat tension to the driver's weight.
- Lever **(b)** for adjusting the distance from the seat to the driving controls.

Note: *Do not change position of the driver's seat while the machine is moving. The “OPERATOR PRESENCE” safety device will prevent all machine movements if an operator is not seated.*



Always wear the seat belt provided when operating the roller.

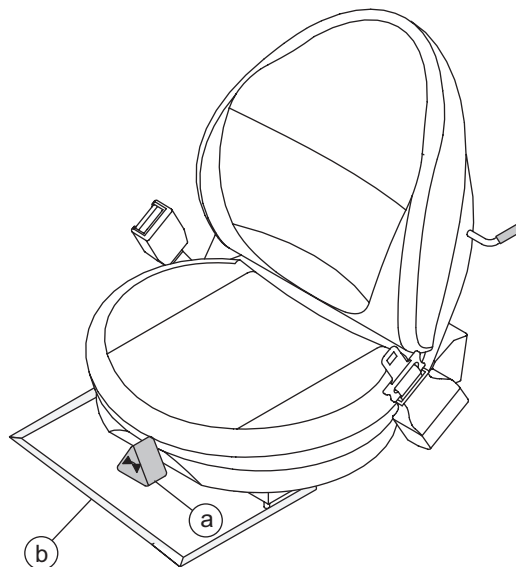

wc_gr002962

3.13 Scraper Bars

See Graphic: *wc_gr003447*

Scraper bars, located in front of and behind each drum, are used to prevent dirt and asphalt from sticking to and accumulating on the drum surface.

These scrapers are spring loaded. They may be set in the travel position (**a**) or the scraping position (**b**) by flipping the bar up or down.

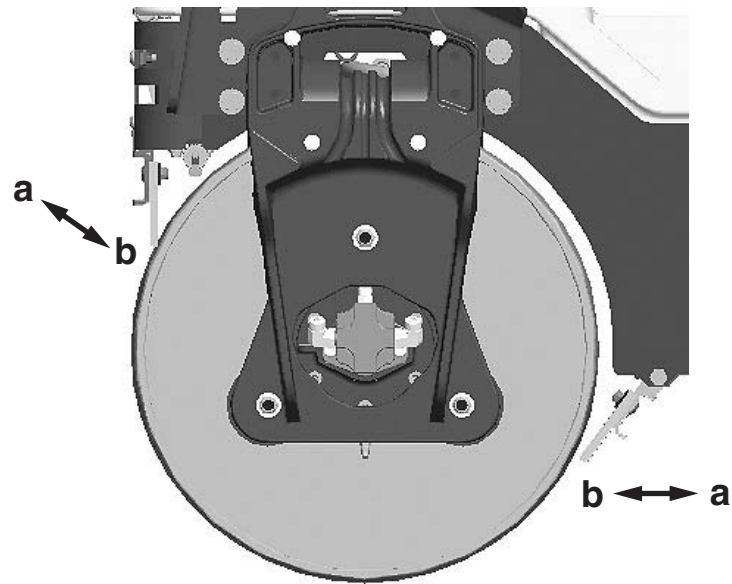

wc_gr003447

3.14 Anti-Vandalism Protection and Machine Access

Parts of the machine which may be subject to theft or vandalism when the vehicle is parked unattended can be padlocked to prevent unauthorized access or use.

Lockable parts are:

- Engine cover.
- Control panel.
- Fuel cap.

To lock the engine cover, close the cover and attach a padlock to the fastener.

RD 16 only: The control panel cover is stored on the front of the control column during operation and service. To lock the control panel, place the cover on the panel and attach a padlock to the fastener.

Note: *Padlocks are not supplied with the machine.*

To lock the fuel cap, close cap completely and push in the locking tab on the cap and attach padlock.

3.15 Articulation Joint Lockarm

See Graphic: *wc_gr002956*

A lockarm (**23**), located below the articulated joint, is provided to secure the front and rear halves of the roller together. Once secured, the lockarm prevents the two halves from swinging together.



WARNING

To avoid being pinched by machine halves, set the lockarm before lifting the machine for transport or repairs!

To set lockarm, release it from its holder and swing it out from its stored position. Place the forward end of the arm into the hole provided in the front frame of the machine. Secure it in this position using the large hairpin cotter provided.



WARNING

ALWAYS disengage and stow locking bar for the articulated steering joint before operating machine. The machine cannot be steered when the locking bar is engaged.

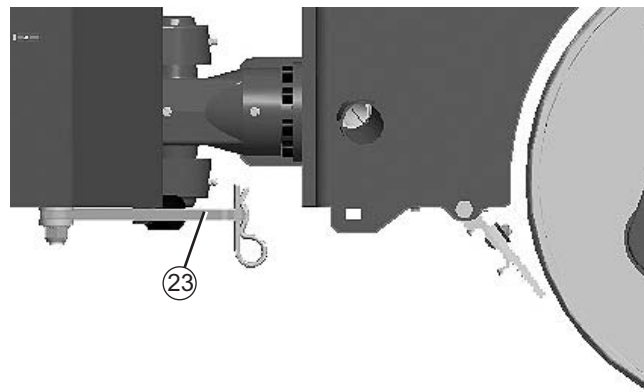

wc_gr002956

3.16 Operation on Slopes

See Graphic: *wc_gr003448*

When operating on slopes or hills special care must be taken to reduce the risk of personal injury or damage to the equipment. Always operate the machine up and down hills rather than from side to side. For safe operation and for protection of the engine, continuous duty use should be restricted to front/rear slopes of 17° (30% grade) or less.



NEVER operate machine on side slopes. The machine may roll over, even on stable ground. Always operate the machine parallel to the slope; never perpendicular.

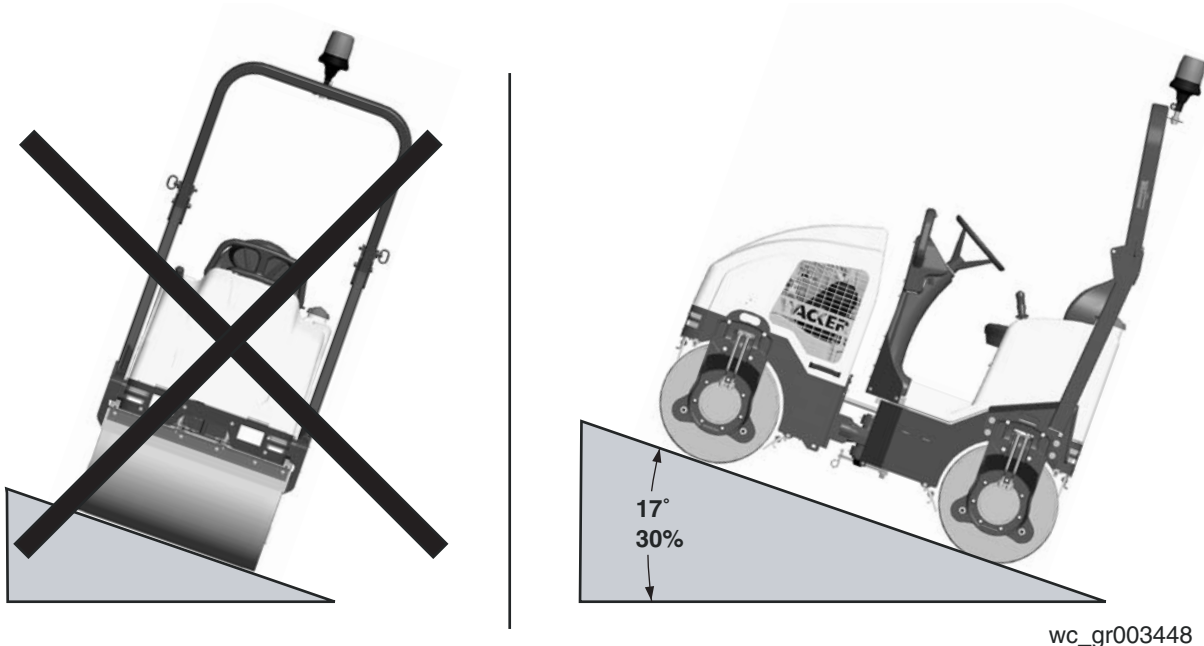

3.17 Recommended Fuel—RD 16

The engine requires No. 2 diesel fuel. Use only fresh, clean fuel. Fuel containing water or dirt will damage the fuel system. Consult the engine owner's manual for complete fuel specifications.

3.18 Recommended Fuel—RD 12

The engine requires regular grade unleaded gasoline. Use only fresh, clean gasoline. Gasoline containing water or dirt will damage fuel system. Consult engine Owner's Manual for complete fuel specifications.

3.19 Before Starting

Before starting the machine check the following:

- Engine oil level
- Engine coolant level (RD 16 only)
- Hydraulic fluid level
- Condition of fuel lines
- Condition of air cleaner
- Operation of the brake system
- Fuel level
- Water level
- Condition of safety belt
- Scraper bars—clean and properly adjusted

Note: *All fluid levels should be checked with the machine on a level surface.*

Ensure that regular maintenance has been carried out.

Ensure that the driver's platform is clean.

Always use the steps and handrails when climbing on and off the machine.



Always wear the seat belt provided when operating the roller.

3.20 Starting—RD 16

See Graphic: wc_gr002952



WARNING

Exhaust gases are toxic. Do not start the engine in enclosed spaces.

- 3.20.1 Sit down in the operator's seat and fasten the seat belt.
- 3.20.2 Set the forward/reverse control **(15)** in the NEUTRAL position.
- 3.20.3 Press the parking brake button in **(42)** to set parking brake.

Note: *The roller will not start unless the forward/reverse control is in the NEUTRAL position.*

- 3.20.4 Turn the ignition switch **(55)** to the ON position. The glow plug indicator **(58)** will illuminate signifying the glow plugs are on. The glow plug indicator will stay on; approximately 30 seconds at 0°C (32°F). **Do not** start the engine until the glow plug indicator light goes out.
- 3.20.5 Turn the ignition switch **(55)** to the START position.

NOTICE: Do not crank the engine starter for more than 15 seconds at one time. Longer cranking cycles could lead to starter damage.

Note: *The ignition switch has an anti-restart feature. If the engine does not start, the switch will need to be turned to the OFF position before it will allow the engine to be cranked again.*

- 3.20.6 Allow the engine to warm up for a few minutes before operating the roller.
- 3.20.7 Disengage the parking brake by pulling the parking brake button out.
- 3.20.8 Quickly press and release the upper half of the throttle switch **(54)** to bring the engine to high throttle.



WARNING

Prolonged exposure to high noise levels can damage your hearing. Wear appropriate hearing protection while operating the roller.

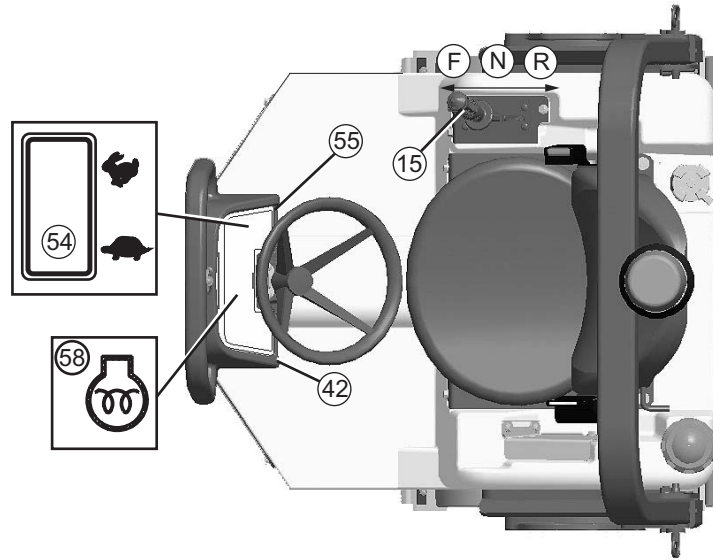

wc_gr002952

3.21 Stopping/Parking—RD 16

See Graphic: *wc_gr002954*

- 3.21.1 Stop the machine on a flat surface with a suitable load bearing capacity.
- 3.21.2 Turn the vibration off by pressing the vibration control button **(10)** on the forward/reverse lever **(15)**.
- 3.21.3 Press the water spray switch **(61)** to the OFF position.
- 3.21.4 Set the forward/reverse control **(15)** to the NEUTRAL position.
- 3.21.5 Return the engine throttle to idle by pressing the lower half of the throttle switch **(54)** and allow the engine to cool down.
- 3.21.6 Press the parking brake button **(42)** to set the parking brake. Always set the parking brake before leaving the machine.



If the vehicle constitutes a hazard or obstacle to traffic when parked, it should be marked with signs, lights, and other warnings.

If the machine must be parked on a sloping surface, chock the drums with wedges to prevent any vehicle movement.

- 3.21.7 Stop the engine by turning the ignition switch to the OFF position **(55)**.

Note: *On the RD 16, the parking brake is automatically applied within the drive motors. The brakes are applied under the following conditions:*

- *engine is not running*
- *engine is running and the operator is not on the seat*
- *parking brake button is pushed*

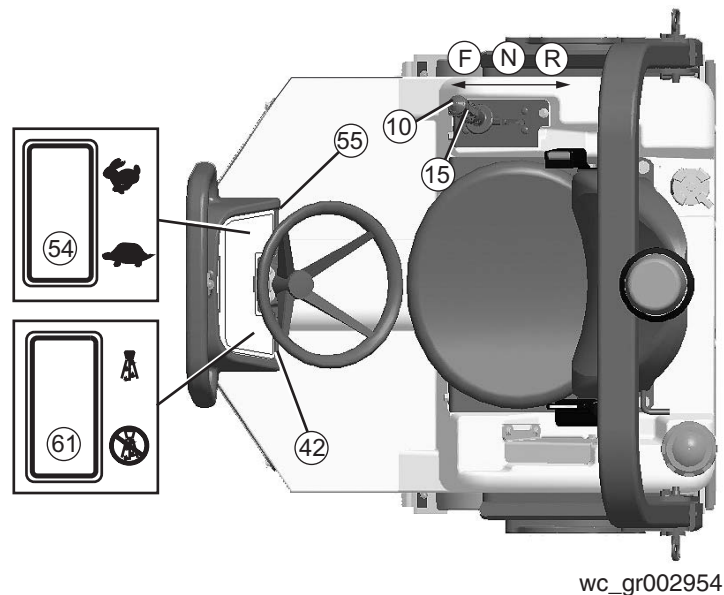

3.22 Parking Brake Button—RD 16

See Graphic: *wc_gr002954*

To hold the machine in a stopped position (parked), there is a mechanical parking brake on each drum drive motor. The mechanical parking brakes are spring-activated and hydraulically released (SAHR) type brakes. The brakes are applied when the engine is switched off or the operator leaves the seat.

When pushed in, the parking brake button **(42)** stops all travel (either forward or reverse) and applies the brake. The brakes can be released by pulling the parking brake button out.

The forward/reverse control **(15)** must be in the NEUTRAL position to allow the release of the brakes. If the forward/reverse control is not in the NEUTRAL position when the parking brake is released, the brakes will not be released.

NOTICE: Under normal operating conditions, do not use the parking brakes when the machine is moving. The parking brakes should only be used in cases of **emergency** when the machine is moving, e.g., following failure of the main hydraulic braking system (moving the forward/reverse control to the NEUTRAL position) or in a runaway condition traveling down a slope. Using the parking brake while the machine is moving may cause damage to the drive motors.

3.23 Starting—RD 12

See Graphic: wc_gr002951



WARNING

Exhaust gases are toxic. Do not start the engine in an enclosed space.

- 3.23.1 Sit down in the operator's seat and fasten the seat belt.
- 3.23.2 Set the forward/reverse control **(15)** in the neutral position.
- 3.23.3 If the engine is cold, move the choke lever **(44)** to the left into the CLOSED position. If the engine is warm, move the choke control to the right in the OPEN position.

Note: *The roller will not start unless the forward/reverse control is in the NEUTRAL position.*

- 3.23.4 Check that the parking brake **(42)** is set. To set the brake, pull the brake lever up until the brake pad engages the drum. To release the brake lever, lower the lever. Always set the parking brake before leaving the machine.
- 3.23.5 Turn the ignition switch **(55)** to start the engine. If the vibration indicator light **(50)** is on, turn the vibration off by pressing the vibration control button **(10)**.

NOTICE: Do not crank the engine starter for more than 15 seconds at one time. Longer cranking cycles could lead to starter damage.

Note: *The ignition switch has an anti-restart feature. If the engine does not start, the switch will need to be turned to the OFF position before it will allow the engine to be cranked again.*

- 3.23.6 Gradually place the choke lever in the OPEN position as the engine warms up. Allow the engine to warm up for a few minutes before operating the roller.
- 3.23.7 Before moving the machine, release the parking brake by lowering the brake lever.
- 3.23.8 Quickly press and release the upper half of the throttle switch **(54)** to bring the engine to high throttle.



WARNING

Prolonged exposure to high noise levels can damage your hearing. Wear appropriate hearing protection while operating the roller.

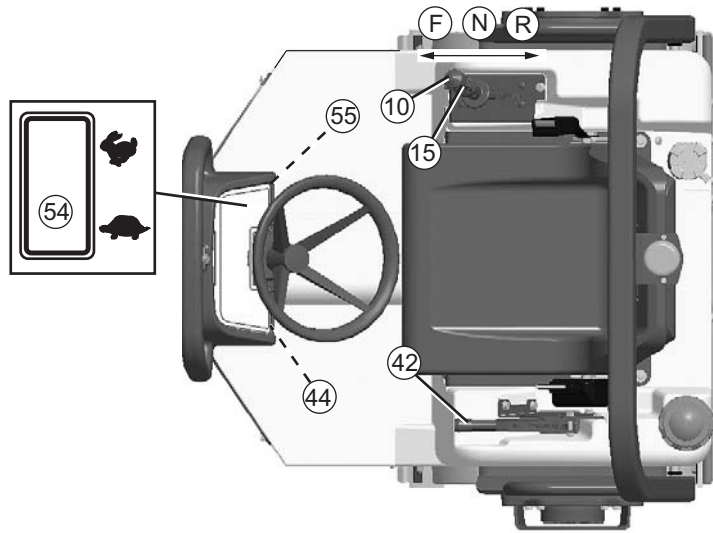

wc_gr002951

3.24 Stopping/Parking—RD 12

See Graphic: *wc_gr002953*

- 3.24.1 Stop the machine on a flat surface with a suitable load bearing capacity.
- 3.24.2 Turn the vibration off by pressing the vibration control button **(10)** on the forward/reverse lever **(15)**.
- 3.24.3 Press the water spray switch to the OFF position **(61)**.
- 3.24.4 Set the forward/reverse control **(15)** to the NEUTRAL position.
- 3.24.5 Return the engine throttle to idle by pressing the lower half of the throttle switch **(54)** and allow the engine to cool down.
- 3.24.6 Set the parking brake **(42)**. To set the parking brake, pull the brake lever up until the brake pad engages the drum. To release the brake, lower the brake lever. Always set the parking brake before leaving the machine.

Note: *The parking brake engages the rear drum only.*

- 3.24.7 Stop the engine by turning the ignition switch **(55)** to the OFF position.



If the vehicle constitutes a hazard or obstacle to traffic when parked, it should be marked with signs, lights, and other warnings.

If the machine must be parked on a sloping surface, chock the drums with wedges to prevent any vehicle movement.

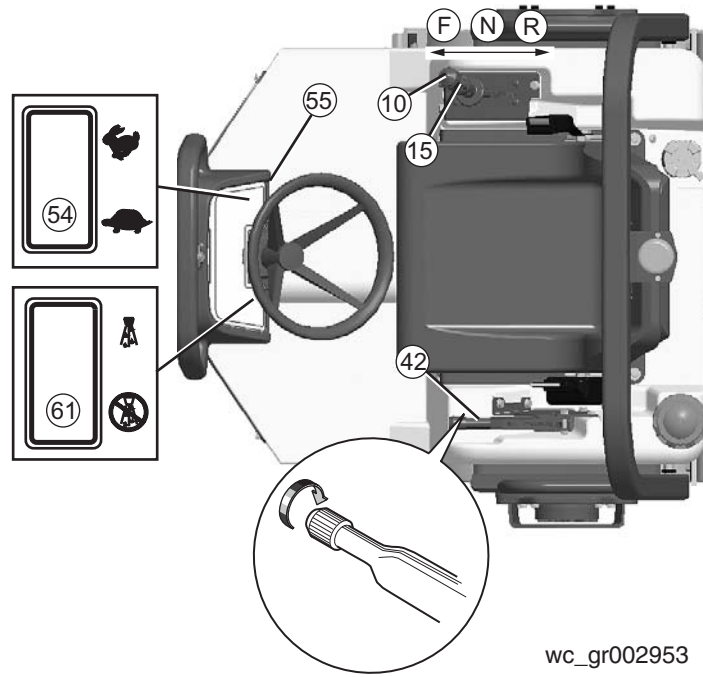

wc_gr002953

3.25 Parking Brake—RD 12

See Graphic: *wc_gr002953*

To hold the machine in a stopped position (parked), there is a mechanical parking brake on the rear drive motor. The engine will automatically shut off when the operator leaves the seat, but the parking brake must be set manually.

To set the parking brake **(42)**, pull the brake lever up until the brake pad engages the rear drum. Always set the parking brake before leaving the machine. To release the parking brake, lower the brake lever. The forward/reverse control **(15)** should be in the NEUTRAL position when the parking brake is released.

The parking brake is connected to the brake pads and can be adjusted by turning the knob on the end of the handle. See section *RD 12 Parking Brake Adjustment*.

NOTICE: Under normal operating conditions, do not use the parking brake when the machine is moving. The parking brake should only be used in cases of **emergency** when the machine is moving, e.g., following failure of the main hydraulic braking system (moving the forward/reverse control to the NEUTRAL position) or in a runaway condition traveling down a slope. Using the parking brake while the machine is moving may cause damage to the drive motor.

3.26 Parking Brake Adjustment—RD 12

See Graphic: *wc_gr002953*

The parking brake is located on the rear drive motor drum support, and is used to prevent the roller from moving when the engine is turned off.

Adjust brake for proper holding force as follows:

- 3.26.1 Unscrew brake lever knob **(42)** until brake can be applied with moderate force (approx. 30 lbs.).
- 3.26.2 Start roller on level ground and try to travel forward and reverse with brake applied. If roller drives through brake, stop machine, tighten lever knob one turn and repeat process.
- 3.26.3 When machine no longer moves with brake set, stop machine, turn knob one more turn and brake is properly set.

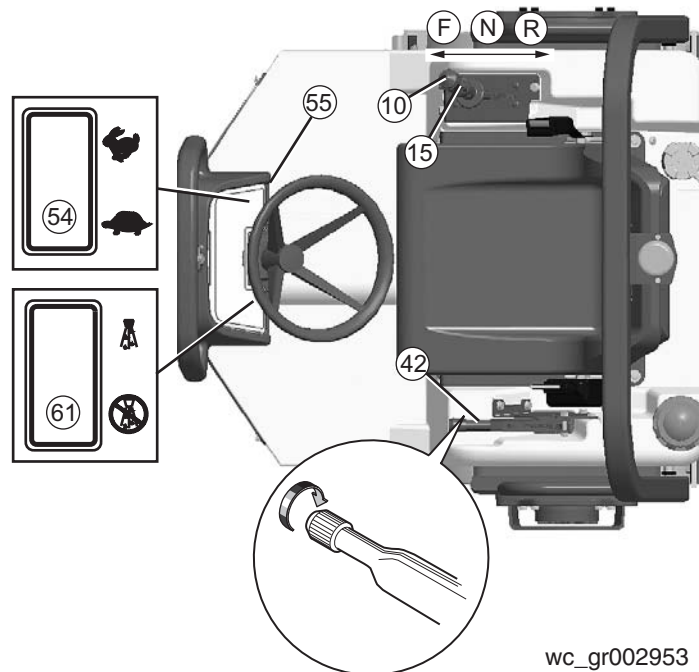

3.27 Direction and Speed

See Graphic: wc_gr002953, wc_gr002954

The forward/reverse control **(15)** controls both the direction and speed of the roller. Use the control lever, rather than the throttle, to control the speed of the machine while compacting.

Speed is controlled by the amount the lever is moved in the direction of travel—forward or reverse.

During operation, to run the machine at full throttle, press and release the upper half of the throttle switch (HIGH) **(54)**. This ensures maximum travel speeds and will produce the best compaction results. Operating the machine at slower engine speeds will reduce compaction, slow down machine functions, and damage hydraulic components.

3.28 Transmission

See Graphic: *wc_gr002953, wc_gr002954*

Both roller drums are fitted with hydraulic motors which are driven by an infinitely variable displacement pump and hydrostatic transmission. Forward and reverse travel are selected using a forward/reverse control **(15)** located next to the driver's seat. In order to comply with safety standards, the machine has a device which only enables starting of the engine when the forward/reverse control is in the NEUTRAL position.

Forward/reverse control

Shift the forward/reverse control **(15)** into FORWARD **(F)** or REVERSE **(R)** according to the direction of travel desired. The further forward or reverse the control is positioned, the faster the roller will travel.

Road speed is the same in both FORWARD and REVERSE. If you wish to change direction of travel from FORWARD to REVERSE or vice versa, move the control to the NEUTRAL position **(N)**, allow the vehicle to come to a complete stop, then move the control in the direction desired.

During operation run the machine at high throttle. Quickly press and release the upper half of the throttle switch **(54)** to bring the engine to high throttle.

When negotiating gentle slopes, keep the engine at high throttle and the forward/reverse control at the minimum speed position.

NOTICE: This vehicle has a hydrostatic transmission which means that the forward/reverse control can also be used as an engine brake. Shifting the control to the NEUTRAL position stops the machine travel.

NOTICE: Never drive the machine at low idle speed. Driving the machine at low idle speed can damage the drive pump.

3.29 Vibration

See Graphic: *wc_gr002955*

The vibration is turned ON or OFF by a push button (10) located on the forward/reverse control (15). Press the button to turn vibration ON; press it again to turn it OFF. The vibration ON indicator (50) will light when vibration is on. The vibration can be turned on while operating in either forward or reverse and will remain on until it is turned off.

On the RD 16, select either the front drum vibration or dual drum vibration by pressing the vibration switch (63) on the control panel.

CAUTION: If the machine has been turned off with the vibration on, the vibration will come on as soon as the machine is restarted. Therefore, for easier starting and to keep the surface finish smooth, be ready to switch vibration off should it come on while cranking the engine.

Note: *The vibration will remain on even when the forward/reverse control (15) is in NEUTRAL. When operating on asphalt and in order to keep the surface finish smooth, turn the vibration off before stopping the roller.*

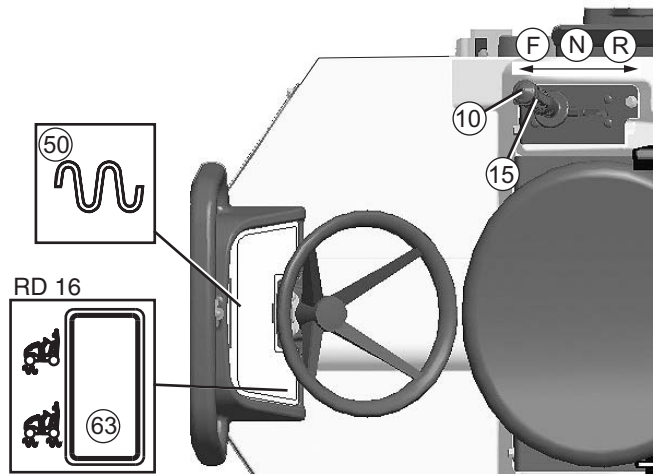

wc_gr002955

3.30 Water Spray System

See Graphic: *wc_gr002946, wc_gr002947, wc_gr003638*

Water from the tank is fed to the spray bars by an electric pump. The flow of the water is controlled by a switch and a rotary dial.

Press the upper half of the water spray switch **(61)** to turn the water pump on. Turn the water spray dial **(62)** clockwise to increase the spray frequency. Turn the water spray dial counter-clockwise to decrease the spray frequency. Press the lower half of the water spray switch **(61)** to turn the water pump off.

Only use clean water. Dirty water, even when filtered, will rapidly clog the tubes of the spraying equipment.

During winter, or when temperatures drop to below 0°C (32°F), drain the water tank and spraying equipment. Run the water pump to remove excess water from the system. Drain the water through the water drain plug **(41)** located near the bottom of the rear frame, through the sprayer end plugs, and the water filter. Freezing water may cause broken hoses, filters and water pumps and may deform the water tank.

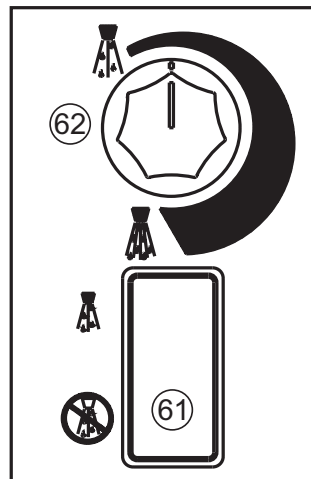

wc_gr003638

3.31 Battery Disconnect—RD 16

This machine is equipped with a battery disconnect switch located in the engine compartment.

To disconnect and isolate the electrical system from the battery, remove the wing-nut and remove the cable from the stud.

To reconnect the battery, place the battery cable on the stud and secure with the wing-nut.



Isolate the battery before performing any maintenance operations on electrical equipment.

3.32 Auxiliary Battery Positive Terminal

This machine is equipped with an auxiliary battery positive terminal (45) located on top of the hydraulic tank (RD 12) or above the battery disconnect stud (RD 16).



CAUTION! Electric shock hazard. Never touch this terminal and a metal portion of the machine simultaneously.



wc_gr004357

Notes:

3.33 Panel Indicator Lights—RD16 IRH / RD16-90 / RD16-100

See Graphic: *wc_gr004117*

Engine coolant temperature indicator (48)

This warning light illuminates to indicate that the engine has overheated and the engine will shut down.

NOTICE: Trace the cause of overheating and rectify the situation before operating the machine.

Low oil pressure indicator (49)

This warning light illuminates when the ignition switch (55) is in the on position and the engine is not running; it goes out once the engine has started.

If the light illuminates when the engine is running, it indicates that the oil pressure is low and the engine will shut down.

Possible causes for the light to illuminate:

- Oil level is too low.
- Incorrect oil viscosity for the time of year.
- Fault in the oil circuit.

Do not operate the machine if the light is illuminated.

Vibration ON indicator (50)

This indicator light illuminates to indicate that the vibration is on.

Low fuel indicator (56)

This indicator light illuminates to indicate that the fuel level is low.

Air filter indicator (57)

This indicator light illuminates to indicate that the air cleaner needs to be changed.

Glow plug indicator (58)

This indicator light illuminates to indicate that the glow plugs are on.

Parking brake button indicator (59)

This indicator light illuminates to indicate that the parking brake button is activated.

Battery indicator (60)

This indicator light illuminates when the battery is not charging.

RD 16 IRH

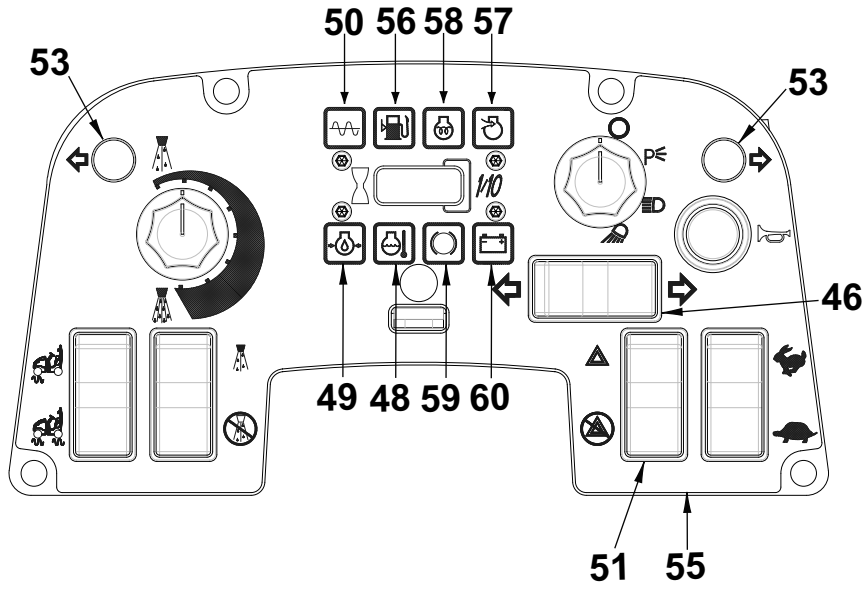

RD 16-90
RD 16-100

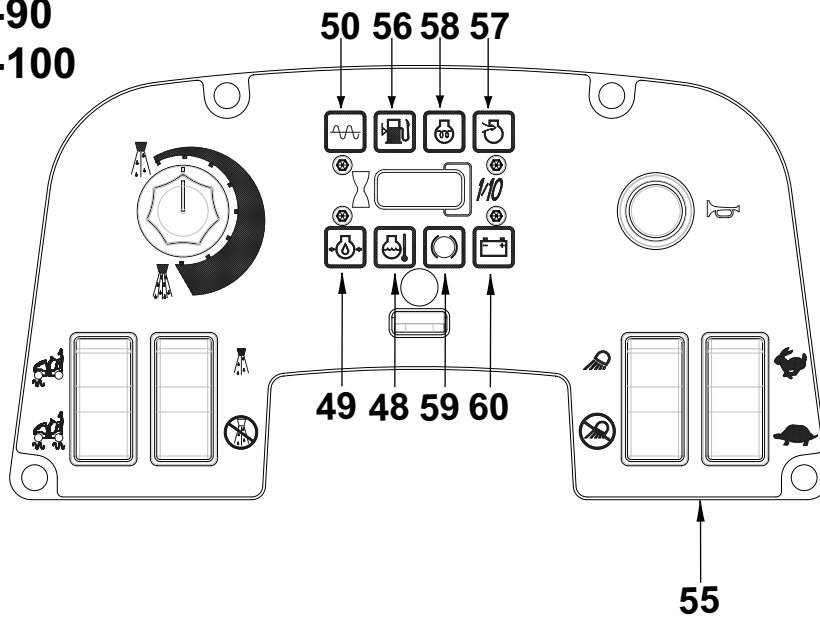

wc_gr004117

3.34 Turn Signal/Hazard Lights (if equipped)—RD16

See Graphic: *wc_gr004117*

These switches are only available on machines equipped with the optional roading light package.

Turn Signal Switch

Press the turn signal switch **(46)** to activate the desired turn signal. The signal lights **(53)** will flash when the turn signal switch is operating. Return the turn signal switch to the middle position to deactivate the turn signal.

Hazard Lights

Press the hazard light switch **(51)** to the ON position to activate the hazard lights. The turn signal lights **(53)** will flash to indicate function. Press the hazard light switch to the OFF position to deactivate the hazard lights.

3.35 Panel Indicator Lights—RD12

See Graphic: *wc_gr004118*

Vibration on indicator (50)

This indicator light illuminates to indicate that the vibration is on.

Low fuel indicator (56)

This indicator light illuminates to indicate that the fuel level is low.

RD 12

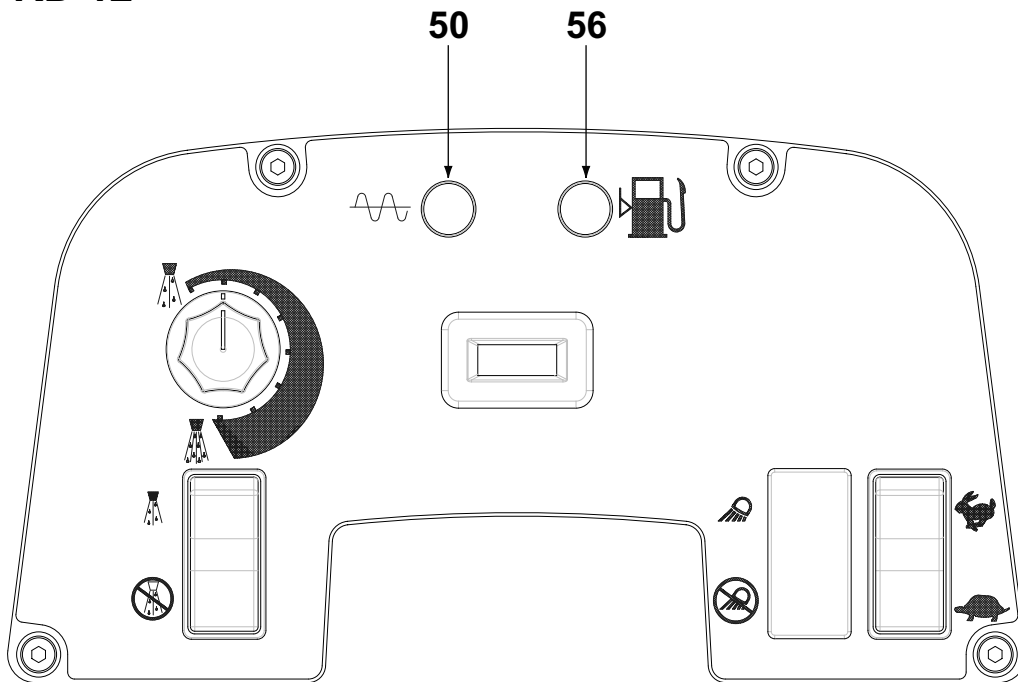

wc_gr004118

3.36 Adding Ballast to Rear Drum—RD 12

See Graphic: *wc_gr002961*

On the RD 12, only the rear drum can be filled with ballast to provide additional weight. Add ballast through plug opening **(26)**.

Drum Capacity: 114 liters (30.2 gal.)

Added Weight (water ballast): 113 Kg (250 lbs.)

If water is used as ballast in areas where temperatures are below freezing, add antifreeze or drain drum after use.

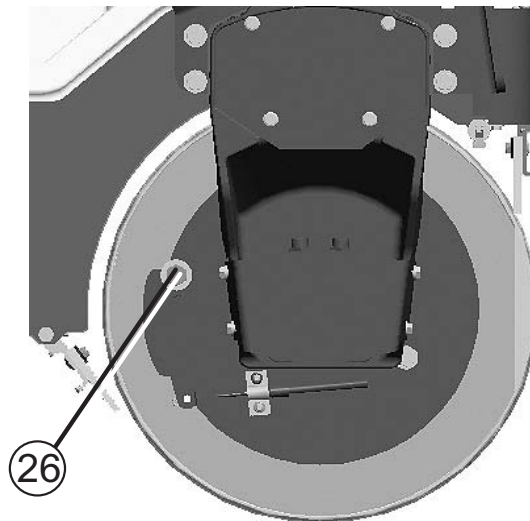

wc_gr002961

4 Maintenance

4.1 Honda Engine Maintenance Schedule—RD 12

The chart below lists basic engine maintenance. Refer to the engine manufacturer's Operation Manual for additional information on engine maintenance.

Honda	Daily before starting	After first 20 hrs.	Every 50 hrs.	Every 100 hrs.	Every 300 hrs.
Check fuel level.	■				
Check engine oil level.	■				
Inspect air filter. Replace as needed.	■*				
Clean engine head and cylinder fins.	■				
Change engine oil and filter.		■		■	
Clean air cleaner.			■*		
Check and clean spark plug.				■	
Clean sediment cup.				■	
Check and adjust idle speed.					■**
Check and adjust valve clearances.					■**
Replace fuel filter.					■**

* Service more frequently in dusty conditions.

**These items should be serviced by an authorized Honda dealer, unless the owner has the proper tools and is mechanically proficient. See Honda Shop Manual.

4.2 Wacker Engine Maintenance Schedule—RD 12

The chart below lists basic engine maintenance. Refer to the engine manufacturer's Operation Manual for additional information on engine maintenance.

Wacker	Daily before starting	After first 20 hrs.	Every 50 hrs.	Every 200 hrs.	Every 500 hrs.
Check fuel level.	■				
Check engine oil level.	■				
Inspect air filter. Replace as needed.	■*			■	
Clean engine head and cylinder fins.	■				
Change engine oil and filter.		■*	■		
Clean air cleaner. Replace as needed.			■*		
Check and clean spark plug.			■	■	
Clean sediment cup/fuel filter.				■	
Check and adjust idle speed					■
Check and adjust valve clearances.					■
Replace spark plug.					■

* Service more frequently in dusty conditions.

4.3 Lombardini Engine Maintenance Schedule—RD 16

The chart below lists basic engine maintenance. Refer to the engine manufacturer's Operation Manual for additional information on engine maintenance.

Lombardini Engine	Daily before starting	Every 100 hrs.	Every 300 hrs.	Every 500 hrs.
Check engine oil and coolant level. Fill to correct level.	■			
Replace air filter if indicator light is on.	■			
Clean engine head and cylinder fins.		■		
Change oil in engine crankcase.		■		
Replace engine oil filter.		■		
Replace fuel filter cartridge.			■	
Clean injectors and check injector pressure.			■	
Check valve clearance.				■

4.4 Roller Maintenance Schedule

	Daily	Every 100 hrs.	Every 600 hrs.	Every 1200 hrs.
Check external hardware.	■			
Check level of hydraulic fluid.	■			
Grease articulated joint.		■		
Grease rear drum drive bearings.		■		
Grease exciter bearings.		■		
Check scraper bars.		■		
Check battery.		■		
Grease steering cylinder ends.		■		
Change hydraulic system return line filter.			■	
Clean battery terminals.			■	
Change hydraulic oil.				■

Daily before starting:

- Check operation of parking brake, making sure it engages.
- Check for leaks around hydraulic hoses and connections.
- Check for leaks around fuel lines and connections.
- Clean engine exterior, cooling fins, and blower housing.
- Check electrical wiring and connections.
- Check operation of NEUTRAL safety switch.
- Inspect seat belt.

New Machines:

- Change engine oil per engine schedule.
- Replace hydraulic system return line filter after first month or 100 hours of operation.

All machines:

- Increase air cleaner/filter inspections and cleaning under dusty conditions.

4.5 Rear Frame Access

See Graphic: *wc_gr004333*

The operator's platform is mounted on hinges and can be lifted open to provide access to the water pump, the water filter, the battery, the hydraulic hoses, and the fuel tank. The platform has lifting cylinders that hold the platform in the open position.

NOTICE: The lifting cylinders do not have enough force to lift and hold the platform in the open position when the tank is filled with water. If there is water in the water tank, drain all water before lifting the platform.

To open:

- 4.5.1 Drain water from the water tank. See section *Water Spray System*.
- 4.5.2 Remove the two bolts (a) locking the operator's platform to each side of the rear frame.
- 4.5.3 Slowly lift up on the steering column (b).

Note: *Lifting the operator's platform too far can damage the lifting cylinders and other components.*

NOTICE: Do not disconnect the lifting cylinders to open the platform further. Fuel may leak out of the fuel cap.

To close:

- 4.5.4 Push down on the platform to return to the operating position.
- 4.5.5 Replace the two bolts (a) locking the operator's platform to each side of the rear frame.

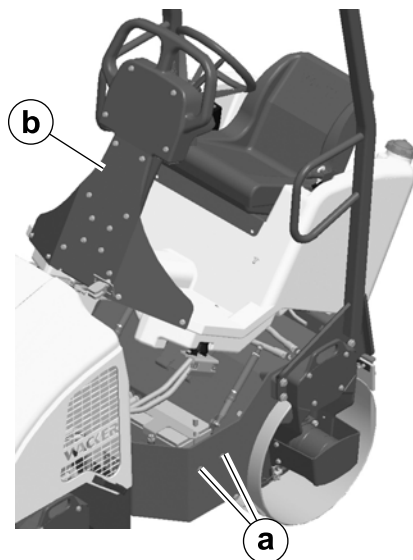

wc_gr004333

4.6 Battery

See Graphic: *wc_gr002565*

Before servicing this machine, make sure the ignition switch is in the OFF position and that the battery is disconnected. Attach a "DO NOT START" sign to the machine. This will notify other personnel that the unit is being serviced and will reduce the chance of someone inadvertently trying to start the unit.



Explosion hazard. Batteries can emit explosive hydrogen gas. Keep all sparks and flames away from the battery. Do not short-circuit battery posts. Do not touch the machine frame or the negative terminal of the battery when working on the positive terminal.



Battery fluid is poisonous and corrosive. In the event of ingestion or contact with skin or eyes seek medical attention immediately.

Dispose of dead batteries in accordance with local environmental regulations.

To disconnect the battery:

- 4.6.1 Stop the machine and shut down the engine.
- 4.6.2 Place all electrical switches in the OFF position.
- 4.6.3 Disconnect the negative (-) battery cable from the battery.
- 4.6.4 Disconnect the positive (+) battery cable from the battery.

To connect the battery:

- 4.6.5 Connect the positive (+) battery cable to the battery.
- 4.6.6 Connect the negative (-) battery cable to the battery.

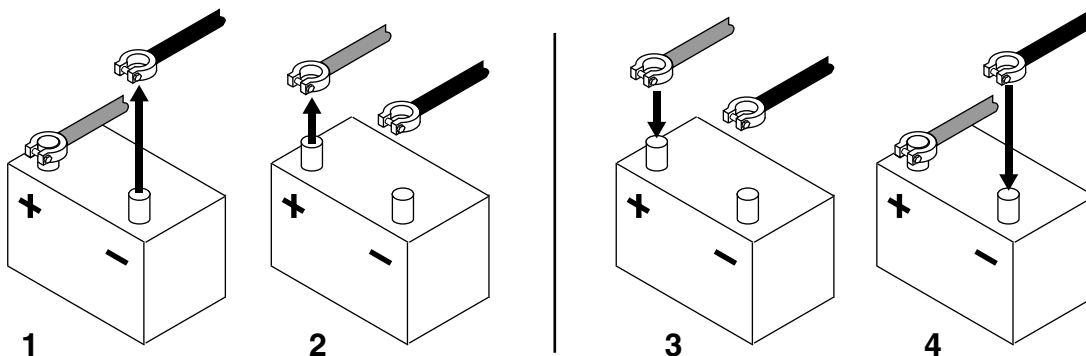

wc_gr002565

Inspect the battery periodically. Keep the battery terminals clean and connections tight.

When necessary, tighten the cables and grease the cable clamps with petroleum jelly.

Maintain the battery at full charge to improve cold weather starting.

NOTICE: Observe the following to prevent serious damage to the machine's electrical system:

- Never disconnect the battery with the machine running.
- Never attempt to run the machine without a battery.
- In the event that the machine has a dead battery, either replace the battery with a fully charged battery or charge the battery using an appropriate battery charger.

4.7 Fuel Filter—RD 12

See Graphic: *wc_gr000163*

- 4.7.1 Change the in-line fuel filter **(a)** once a year or every 300 hours of operation. Check the fuel lines and fittings daily for cracks or leaks. Replace as needed.



WARNING

Gasoline is extremely flammable! Turn the engine off and allow the engine to cool before replacing the fuel filter.

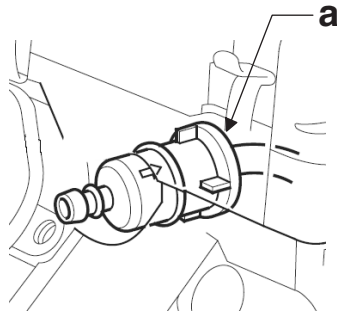

wc_gr000163

4.8 Fuel Filter—RD 16

See Graphic: *wc_gr002999*

- 4.8.1 Change the fuel filter **(a)** every 300 hours of operation. Remove the filter **(a)** from the filter head **(c)**.
- 4.8.2 Install the new filter. If necessary, prime the fuel lines. See section *RD 16 Priming the Fuel System*.



WARNING

Gasoline is extremely flammable! Turn the engine off and allow the engine to cool before replacing the fuel filter.

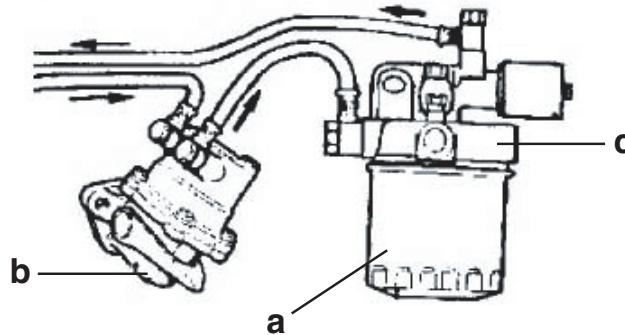

wc_gr002999

4.9 Priming the Fuel System—RD 16

See Graphic: *wc_gr002999*

If the fuel tank has been run completely dry or drained for service, it may be necessary to manually prime the fuel system.

To prime the fuel system:

- 4.9.1 Turn the ignition switch to the ON position **(60)**. This will open the fuel valve.
- 4.9.2 Pump the lever on the fuel pump **(b)** until there is an increase in pumping effort.

4.10 Engine Oil and Filter—RD 12

See Graphic: *wc_gr003000*

Drain the oil while the engine is still warm. To drain oil:

- 4.10.1 Remove the filler cap (**a**) and drain cap (**d**) from the end of the drain hose. Drain oil into a suitable container.

Note: *In the interests of environmental protection, place plastic sheeting and a container under the machine to collect the liquid which drains off. Dispose of this liquid properly.*

- 4.10.2 Re-insert the drain cap and tighten.

- 4.10.3 Fill the engine with the recommended oil to the upper limit mark on the dipstick (**b**). See section *Technical Data* for the oil quantity and type.



WARNING

Danger of burns! Care must be taken when draining hot engine oil. Hot oil can burn!

To change the filter:

- 4.10.4 Drain the engine oil. Remove used filter.

- 4.10.5 Before installing the new filter, lightly oil the filter gasket (**c**) with fresh, clean engine oil. Screw the filter on by hand until the gasket makes contact, then tighten an additional 7/8 turn.

- 4.10.6 Fill the engine with the recommended oil. See section *Technical Data* for oil quantity and type.

- 4.10.7 Start and run the engine to check for leaks. Stop the engine. Recheck the oil level and add oil if required. Refer to the engine owner's manual.

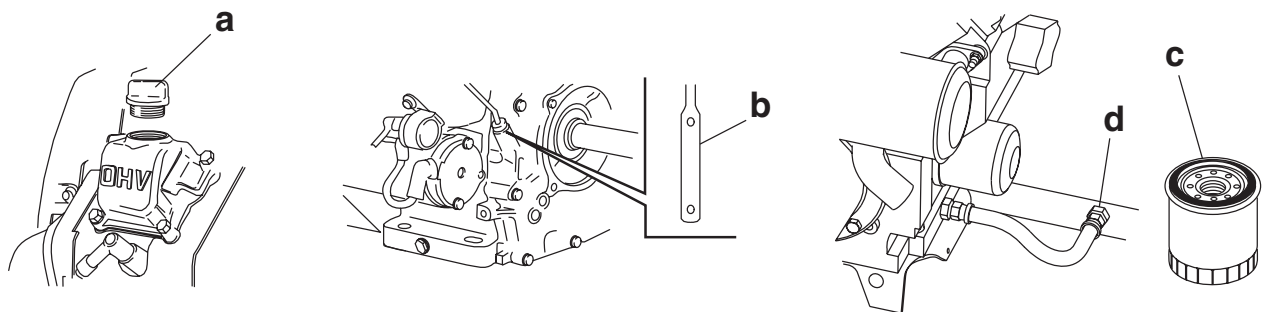

wc_gr003000

4.11 Engine Oil and Filter—RD 16

See Graphic: *wc_gr003780*

Change the oil and the oil filter **(b)** every 250 hours. On new machines, change the oil after first 50 hours of operation. Drain the oil while engine is still warm.

Note: *In the interests of environmental protection, place a plastic sheet and a container under the machine to collect any liquid which drains off. Dispose of this liquid in accordance with environmental protection legislation.*

To change oil:

- 4.11.1 Remove the oil filler cap **(a)** and oil drain plug **(c)**. Drain the oil into a suitable container.
- 4.11.2 Reinstall the drain plug and tighten.
- 4.11.3 Remove and replace the oil filter **(b)**.
- 4.11.4 Remove the oil filler cap **(a)** and fill the engine crankcase with recommended oil. See section *Technical Data* for oil quantity and type.
- 4.11.5 Install the oil filler cap.

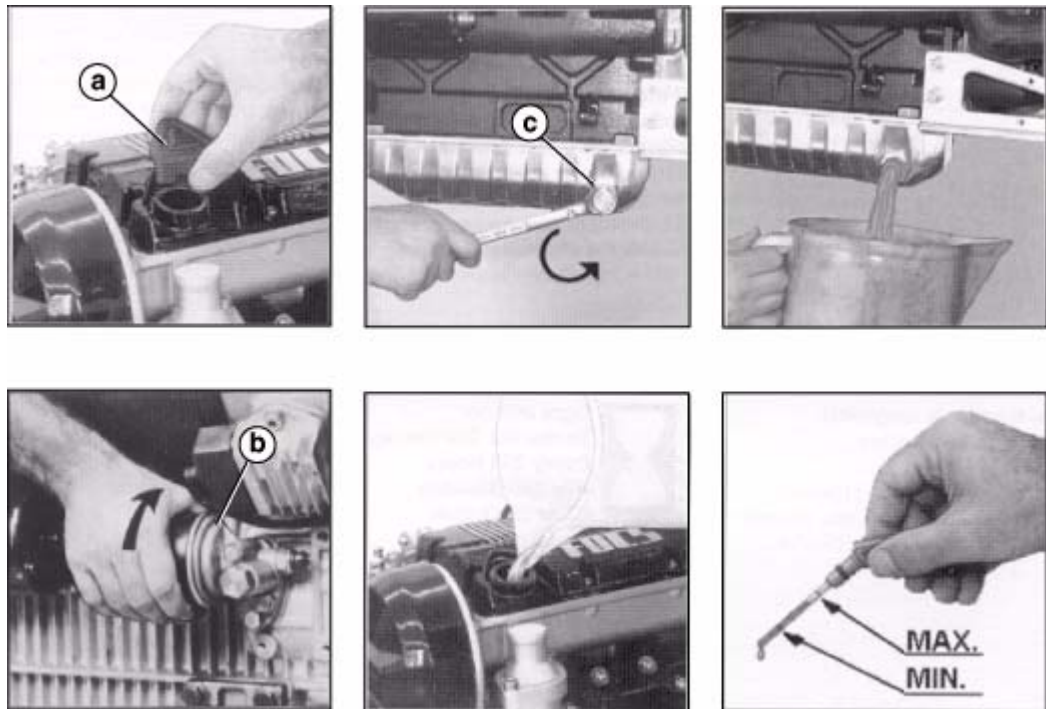

wc_gr003780

4.12 Spark Plug—RD 12

See Graphic: *wc_gr000028*

Clean or replace the spark plug as needed to ensure proper operation. Refer to the engine owner's manual.



The exhaust manifold becomes very hot during operation and remains hot for a while after stopping the engine. Do not touch the exhaust manifold while it is hot.

Note: Refer to section *Technical Data* for the recommended spark plug type and the electrode gap setting.

- 4.12.1 Remove the spark plug and inspect it.
- 4.12.2 Replace the spark plug if the insulator is cracked or chipped.
- 4.12.3 Clean the spark plug electrodes with a wire brush.
- 4.12.4 Set the electrode gap (**a**).
- 4.12.5 Tighten the spark plug securely.

NOTICE: A loose spark plug can become very hot and may cause engine damage.

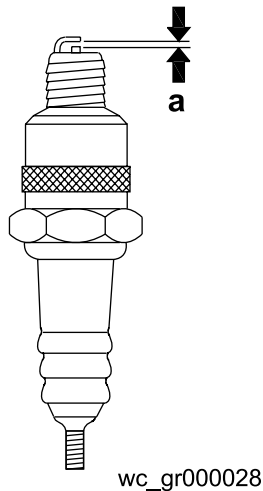

4.13 Honda Engine Air Cleaner—RD 12

See Graphic: *wc_gr000154*



WARNING

NEVER use gasoline or other types of low-flash point solvents for cleaning the air cleaner. A fire or explosion could result.

NOTICE: NEVER run the engine without the air cleaner. Severe engine damage will occur.

The engine is equipped with a dual-element air cleaner. Under normal operating conditions, the elements should be cleaned once every week. Under severe, dry and dusty conditions, the elements should be maintained daily. Replace an element when it is saturated with dirt that cannot be removed.

- 4.13.1 Remove the air cleaner cover (**a**). Remove the filter assembly by pulling it straight up. Inspect both elements for holes or tears. Replace damaged elements.
- 4.13.2 Wash the foam element (**b**) in a solution of mild detergent and warm water. Rinse it thoroughly in clean water. Allow the element to dry thoroughly.
- 4.13.3 Tap the paper element (**c**) lightly to remove excess dirt or blow compressed air through the filter from the inside out. Replace the paper element if it appears heavily soiled.

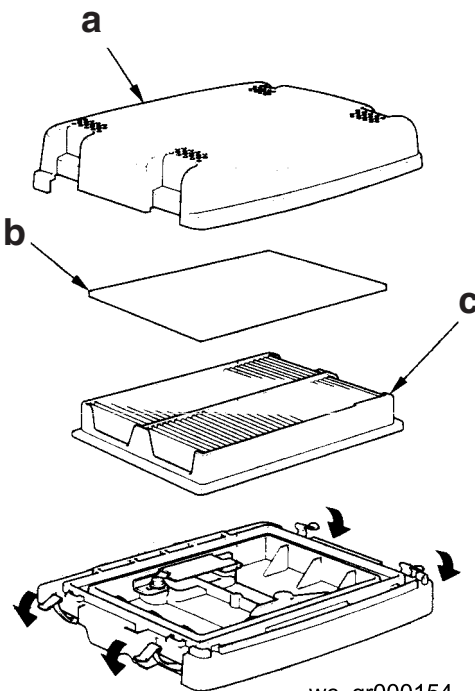

wc_gr000154

4.14 Wacker Engine Air Cleaner—RD 12

See Graphic: *wc_gr003002*



WARNING

NEVER use gasoline or other types of low flash-point solvents for cleaning the air cleaner. A fire or explosion could result.

NOTICE: NEVER run the engine without the air cleaner. Severe engine damage will occur.

The engine is equipped with a dual-element air cleaner. Under normal operating conditions, elements should be cleaned once every week. Under severe, dry and dusty conditions, the elements should be maintained daily. Replace an element when it is saturated with dirt that cannot be removed.

- 4.14.1 Remove the wing bolt (a) and cover (b).
- 4.14.2 To clean the paper element (c), tap it lightly on a flat surface. Replace the paper element if it is damaged or heavily soiled.
- 4.14.3 To clean the foam element (d), wash it in liquid detergent and water. Squeeze it dry in a clean cloth. Once dry, saturate the foam element in engine oil, then squeeze out excess. Replace the foam element if it is damaged or heavily soiled. Re-install the foam element and re-assemble the air cleaner.

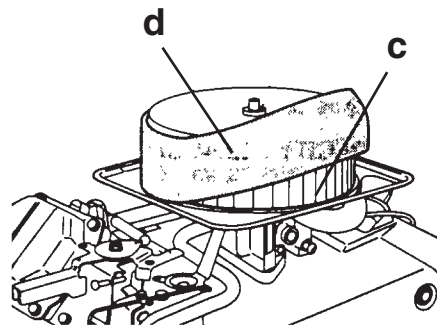
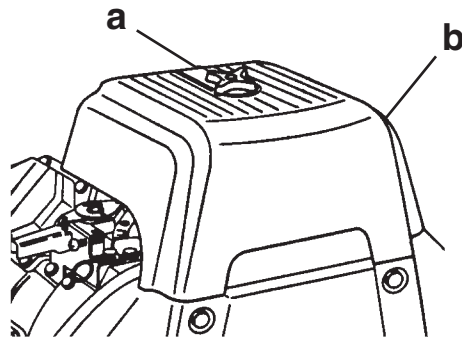

wc_gr003002

4.15 Lombardini Engine Air Cleaner—RD 16

See Graphic: *wc_gr002963*

Replace the air filter cartridge when the air filter warning light illuminates. See section *Control Panel*.

The air cleaner assembly contains a one-piece single element air filter cartridge **(a)**.

To replace the air filter cartridge:

- 4.15.1 Remove the end cover **(b)**, then discard the entire air filter cartridge.
- 4.15.2 Insert a new air filter cartridge, then:
- 4.15.3 Re-install the end cover, making sure that the dust cap **(c)** is clean and is pointing downward.

Periodically, make sure the inlet pipe is free from obstructions.



CAUTION

Check all connections and make sure they are snug. An air leak at the neck clamp or intake pipe can quickly lead to expensive engine repairs.

- Make sure that the intake piping is fully engaged over the neck of the filter to ensure a good seal.
- If the filter housing, neck, or inlet pipe are crushed or damaged, replace them immediately.

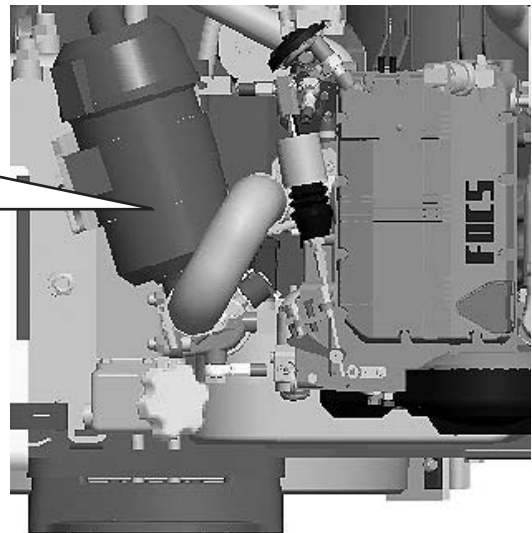
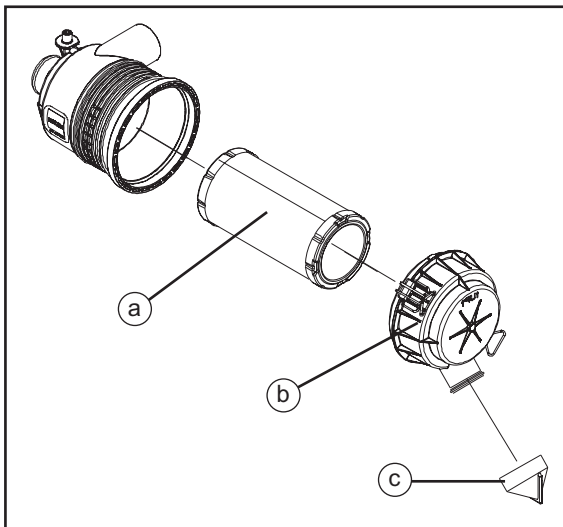

wc_gr002963

4.16 Grease Fittings

See Graphic: *wc_gr003457*

See section *Technical Data* for oil quantity and type.

Articulation Joint Lockarm:

The articulated joint is equipped with grease fittings **(a)** for lubrication.



WARNING

To avoid being pinched by the machine halves, set the lockarm before greasing the articulating joint!

Rear Drum:

The rear drum drive bearing is equipped with a grease fitting **(b)** located at the center of the drum behind the right rear drum support.

Exciter:

The exciter is grease lubricated. There are two grease fittings **(c)**, one on each side of the machine, located behind the front drum supports.

Steering Cylinder:

The steering cylinder is located under the operator's platform. There is a grease fitting near the base and rod ends of the cylinder **(d)**.

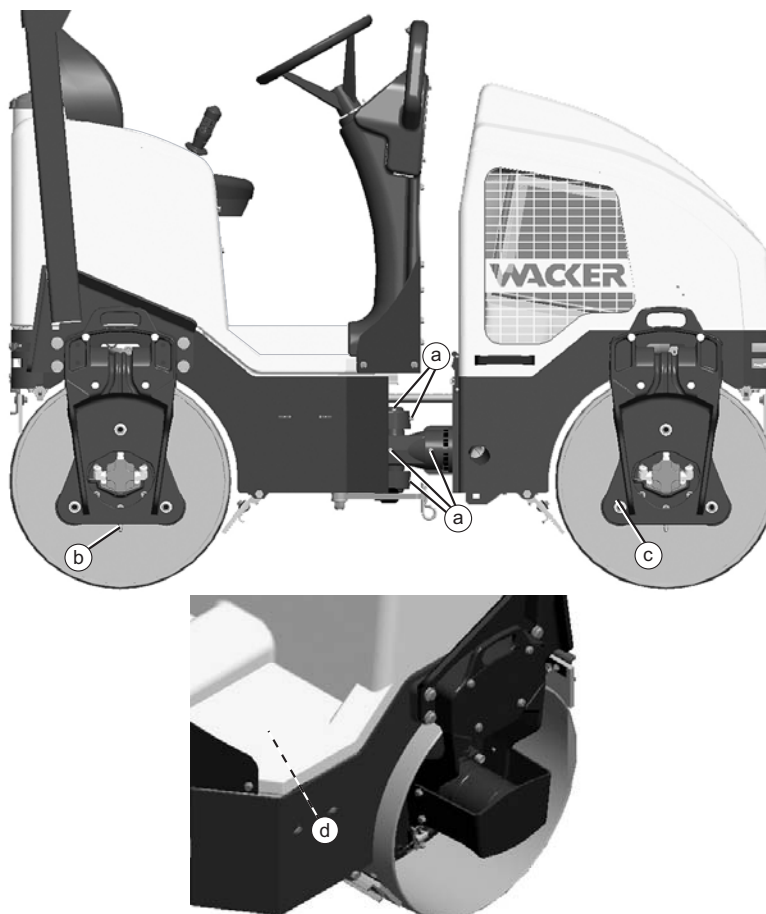

wc_gr003457

4.17 Hydraulic System Cleanliness

Keeping the hydraulic oil clean is a vital factor affecting the service life of hydraulic components. Oil in hydraulic systems is used not only to transfer power, but also to lubricate the hydraulic components used in the system. Keeping the hydraulic system clean will help avoid costly downtime and repairs.

Major sources of hydraulic system contamination include:

- Particles of dirt introduced when the hydraulic system is opened for maintenance or repair
- Contaminants generated by the mechanical components of the system during operation
- Improper storage and handling of hydraulic oil
- Use of the wrong type of hydraulic oil
- Leakage in lines and fittings

To minimize hydraulic oil contamination:

CLEAN hydraulic connections before opening the lines. When adding oil, clean the hydraulic tank filler cap and surrounding area before removing it.

AVOID opening the pumps, motors, or hose connections unless absolutely necessary.

PLUG or cap all open hydraulic connections while servicing the system.

CLEAN and cover the containers, funnels, and spouts used to store and transfer the hydraulic oil.

CHANGE the hydraulic filters and oils at the recommended service intervals.

4.18 Hydraulic Oil Requirements

Wacker recommends the use of a good petroleum-based, anti-wear hydraulic oil in the hydraulic system of this equipment. Good anti-wear hydraulic oils contain special additives to reduce oxidation, prevent foaming, and provide for good water separation.

When selecting hydraulic oil for your machine, be sure to specify anti-wear properties. Most hydraulic oil suppliers will provide assistance in finding the correct hydraulic oil for your machine.

Avoid mixing different brands and grades of hydraulic oils.

Most hydraulic oils are available in different viscosities.

The SAE number for an oil is used strictly to identify viscosity—it **does not** indicate the type of oil (engine, hydraulic, gear, etc.).

When selecting a hydraulic oil be sure it matches the specified SAE viscosity rating and is intended to be used as a hydraulic oil. See section *Technical Data—Lubrication*.

4.19 Hydraulic Oil Level

See Graphic: *wc_gr002959*

A hydraulic oil level sightglass (29) is located on the side of the hydraulic fluid reservoir.

While the machine is turned off, check that the hydraulic oil level is visible at the middle level or higher in the sightglass. If it is not, add oil through the filler port (20) inside the engine compartment. Use only clean hydraulic oil.

Thoroughly clean the top of the filler cap before removing it from the tank. Care should be taken to prevent small dirt particles from entering the system.

If hydraulic oil continually needs to be added, inspect hoses and connections for possible leaks.

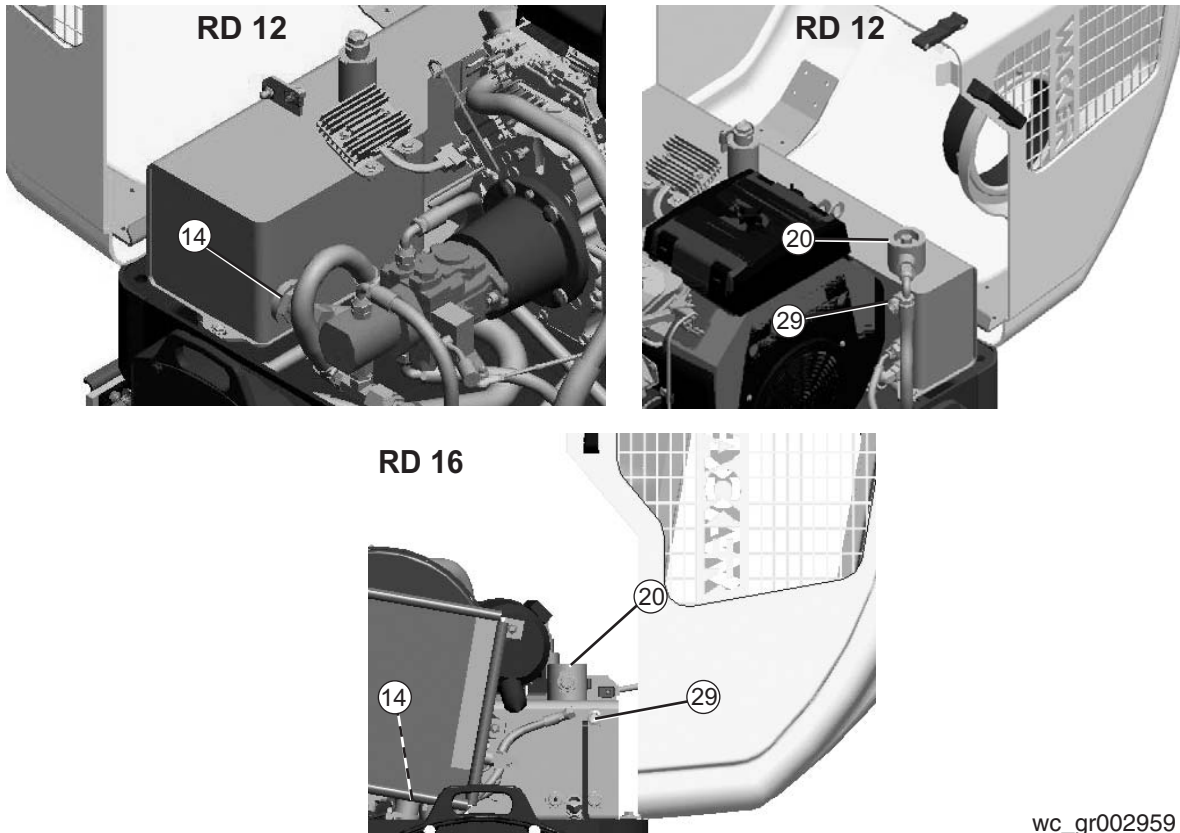

wc_gr002959

4.20 Hydraulic Suction Strainer

See Graphic: *wc_gr002959*

A hydraulic strainer (14) is located in the hydraulic tank. This strainer will not normally require service and does not need to be replaced when changing the hydraulic oil.

4.21 Changing the Hydraulic Oil & Filter

All oils eventually shear or thin out with use, reducing their lubricating ability. In addition, heat, oxidation, and contamination may cause the formation of sludge, gum, or varnish in the system. For these reasons, it is important to change the hydraulic oil at specified intervals. See *Maintenance Schedule*.

- 4.21.1 Remove the filler cap/filter cartridge from top of the hydraulic tank.
- 4.21.2 Remove the drain plug on the drain hose and allow the hydraulic fluid to drain.
Note: *In the interests of environmental protection, place plastic sheeting and a container under the machine to collect the liquid which drains off. Dispose of this liquid properly.*
- 4.21.3 Unscrew the return line filter and replace the filter cartridge.
- 4.21.4 Install the drain plug on the drain hose.
- 4.21.5 Fill the hydraulic tank through the filler port with clean hydraulic fluid.
- 4.21.6 Bleed the hydraulic system. See section *Bleeding the Hydraulic System*.

4.22 Bleeding the Hydraulic System

- 4.22.1 Fill the hydraulic system with clean hydraulic oil until it is visible at the middle level or higher in the sightglass. Do not re-use used hydraulic oil.
- 4.22.2 On the RD 12 only: Disconnect the spark plug wires to prevent the engine from starting.
- 4.22.3 On the RD 16 only: Disconnect the wire located on the fuel solenoid.
- 4.22.4 Crank engine 5–10 seconds. This will allow the oil to fill the inlet lines.
- 4.22.5 On the RD 12 only: Reconnect the spark plug wires.
- 4.22.6 On the RD 16 only: Reconnect the fuel solenoid wire.
- 4.22.7 Place forward/reverse control in the NEUTRAL position. Start the engine and run the machine at idle for 3–4 minutes.
- 4.22.8 With the engine still running at idle, move the machine slowly back and forth from forward to reverse for a short time to bleed air trapped in drive circuit.
- 4.22.9 Switch the engine to high idle for 15–20 seconds. Return to low idle for 1 minute. Repeat 2–3 times to bleed the remaining air from the hydraulic lines.
- 4.22.10 Check the hydraulic oil level and add oil as required.

Note: *If the drive pump chatters or operation is noisy, turn the machine off and check for air leaks in the inlet line of the charge pump.*

4.23 Lifting the Machine

See Graphic: *wc_gr003454*

Stop the engine.



WARNING

Locking the articulated joint lockarm (a)

Before lifting the machine, make sure the articulated joint lockarm is in the LOCKED position. Refer to section *Articulation Joint Lockarm* for information.

Lifting

Use lifting ropes or chains with an appropriate amount of load bearing capacity. Attach the lifting ropes to the lifting eyes (b) on the machine using hooks or shackles. Attach the other end of the ropes to the hook of the lifting equipment. The hook must have a lifting capacity which will support the weight of the machine. Refer to section *Technical Data* for weight information. Lift the machine using four ropes, one rope attached to each lifting eye and a spreader bar that prevents the ropes from contacting the machine.

Note: *The RD 16 includes a spreader bar secured to the inside of the engine hood.*

Use only steel ropes or chains for lifting. Ropes or chains must have the suitable specified lifting capacity and must be at least 2000 mm (6.5 ft.) long. Do not use improvised ropes or chains.

Do not stand under, or get onto, the machine while it is being lifted or moved.

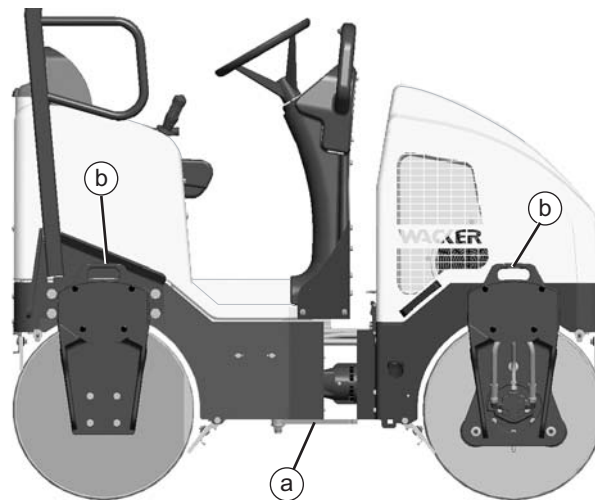

wc_gr003454

4.24 Tying Down and Transporting the Machine

See Graphic: *wc_gr003455*

Lock the articulated joint lockarm. Refer to section *Articulation Joint Lockarm* for information.

When transporting the machine, place blocks in front of and behind each drum and use the front and rear tie-down points (**a**) provided to securely fasten the machine to the trailer (two places). Secure the machine by attaching steel ropes or chains to the tie down points (**a**).

Note: *The transmission is normally braked when the engine is off, or when the hydraulic system is not functioning, unless there is a fault and/or the parking brakes have been manually disabled.*

NOTICE: Do not position ropes or chains across the machine frame or the articulated joint when tying down the machine. Damage to the machine may occur.

NOTICE: Do not use complete deflection of shock mounts when tying down the machine. Damage to the shock mounts may occur.

NOTICE: Do not leave the machine tied down for extended periods of time (except when transporting the machine). Damage to the shock mounts may occur.

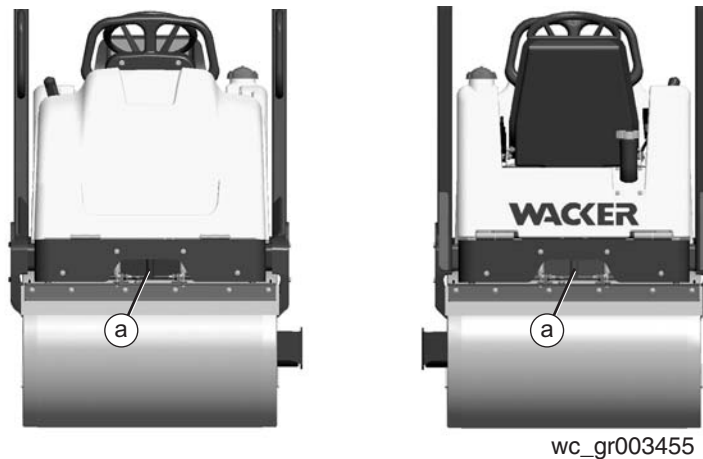

4.25 Storage

If machine is to be stored for more than 30 days:

- Drain the fuel tank and drain the water tank. If ballast was added to the rear drum, also drain the rear drum.
- Change the engine oil.
- On machines with Honda or Wacker engines, remove the spark plugs and pour approximately 3 ml (1 ounce) of SAE 30W oil into each engine cylinder through the spark plug opening. Re-install the spark plugs. Leave the ignition wires disconnected to prevent the engine from starting. Crank the engine for one or two seconds to distribute the oil inside the engine cylinders. Connect the ignition wires.
- Clean the entire roller and engine compartment.
- Remove dirt from the cooling fins on the engine cylinders and on the blower housing.
- Set the lockarm to secure the roller halves together.
- Remove the battery from the machine and charge it periodically.
- Cover the entire machine and place it in a dry, protected area.

4.26 Towing Bypass Valve—RD 12

See Graphic: *wc_gr002960*

The drive circuit is equipped with a towing valve **(43)** to allow oil to bypass the drive motors and let the roller freewheel for towing.

The towing valve should be used in emergency cases where the machine has become bogged down in loose or muddy soil, or cannot be driven due to an engine or hydraulic system failure.



With the towing valve open, the drive circuit has no braking action and the machine will roll freely. Apply the brake or attach the towing device before opening the towing valve. Close the towing valve immediately after the towing operation is complete to prevent the machine from rolling unexpectedly.

To open the bypass, shut the engine off and rotate the shaft on the towing valve counter-clockwise.

When resuming machine operation, make sure the bypass is closed by rotating the shaft on the towing valve clockwise.

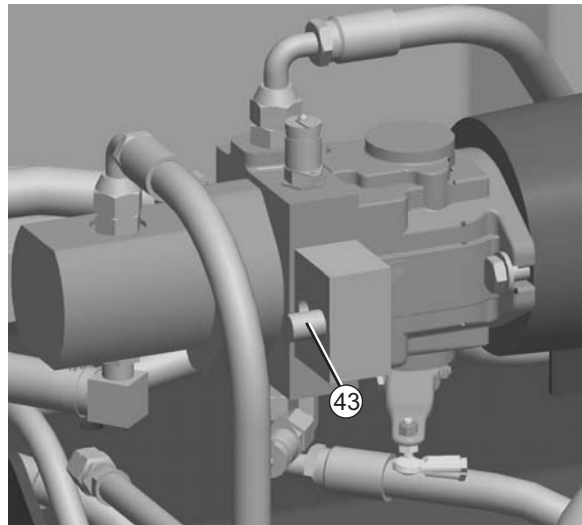

wc_gr002960

4.27 Towing



Improper hookup and towing is dangerous and could result in injury or death to yourself or others.

The towing connection must be rigid, or towing must be done by two machines of the same size or larger than the towed machine. Connect a machine on each end of the towed machine.

Be sure that all necessary repairs and adjustments have been made before a machine that has been towed to a service area, is put back into operation.

These towing instructions are for moving a disabled machine for a short distance at a low speed. Move the machine at a speed of 3 km/h (1.9 mph) or less to a convenient location for repair. **These instructions are only for emergencies.** Always haul the machine if long distance moving is required.

Shielding must be provided on both machines. This will protect the operator if the tow line or the tow bar breaks.

Do not allow an operator to be on the machine that is being towed unless the operator can control the steering and/or the braking.

Before towing, make sure that the tow line or the tow bar is in good condition. Make sure that the tow line or the tow bar has enough strength for the towing procedure that is involved. The strength of the towing line or the tow bar should be at least 150 percent of the gross weight of the towing machine. This is true for a disabled machine that is stuck in the mud and for towing on a grade.

Keep the tow line angle to a minimum. Do not exceed a 30 degree angle from the straight ahead position.

Quick machine movement could overload the tow line or the tow bar. This could cause the tow line or the tow bar to break. Gradual, steady machine movement will be more effective.

Normally, the towing machine should be as large as the disabled machine. Make sure that the towing machine has enough brake capacity, enough weight, and enough power. The towing machine must be able to control both machines for the grade that is involved and for the distance that is involved.

You must provide sufficient control and sufficient braking when you are moving a disabled machine downhill. This may require a large towing machine or additional machines that are connected to the rear. This will prevent the machine from rolling away out of control.

All situation requirements cannot be listed. Minimal towing machine capacity is required on smooth, level surfaces. On inclines in poor condition or on surfaces in poor condition, maximum towing capacity is required.

Attach the towing device and machine before you release the brakes. If the engine is running, the machine can be towed for a short distance under certain conditions. The power train and steering system must be operable.

The operator must steer the machine that is towed in the direction of the tow line.

Ensure that all instructions in this section are followed carefully. Ensure that all instructions in this section are followed exactly.

When the engine is stopped, additional steps may be required before the machine is towed. In order to avoid damaging the power train, the steering system, and the brakes, which may be inoperable, additional steps may be required.

- 4.27.1 Block the drums in order to prevent movement of the machine. Do not remove the blocking until the tow vehicle has been positioned and the tow lines are in place.
- 4.27.2 Manually release the parking brake. This will prevent excessive wear and damage to the braking system when towing.
- 4.27.3 On the RD 16 only, manually release the parking brake. See section *RD 16 Manually Releasing Parking Brake*.
- 4.27.4 On the RD 12 only, open bypass valve. See section *RD 12 Bypass Valve*.
- 4.27.5 Attach the tow line to the machine at the tow points.
- 4.27.6 Attach the tow line to the vehicle that is used to tow the disabled machine.
- 4.27.7 Remove the blocks from the drums.
- 4.27.8 Tow the disabled machine at a slow rate of speed to the desired location.
NOTICE: Do not tow the roller long distances or at speeds greater than 3 km/h (1.9 mph). Damage to the drive motors may occur.
- 4.27.9 Once the machine is at the desired location, securely block the drums. This will prevent movement of the machine.
- 4.27.10 On the RD 12 only, close the bypass valve.
- 4.27.11 Manually re-engage the parking brake.
- 4.27.12 Detach the tow lines.

4.28 Manually Releasing Parking Brake—RD 16

See Graphic: *wc_gr002964*

There are two drive motors on the roller—one on each drum. Each drive motor includes a parking brake that is spring activated and hydraulically released (SAHR).

To manually release the brakes:

Note: *Carry out the procedure on both drums.*

- 4.28.1 Chock each drum to prevent the machine from moving.
- 4.28.2 Lock the articulated steering joint. See section *Articulation Joint Lockarm*.
- 4.28.3 Remove the plugs **(a)** in order to access the release screws.
- 4.28.4 Press and turn each release screw in until its threads catch in the brake plate. Tighten each screw until the spring on each screw is fully compressed. You will feel a substantial difference in the amount of torque required to turn the screw once its spring is fully compressed. Then, continue to tighten (turn clockwise) the two release screws to compress the brake plate springs. Alternate back-and-forth between the two screws, turning approximately 45° at a time, until the drums are no longer held by the brake plate. The brake plate should release after turning each screw approximately 120° total. To test if the brake is free, manually turn the drum.
- 4.28.5 Replace the plugs **(a)**.

Note: *After repair, ensure that the releasing screws are back in the normal operating position.*

Note: *Replacement drive motors come with the brakes in the ON position.*

NOTICE: Do not tow the roller long distances or at speeds greater than 3 km/h (1.9 mph). Damage to the drive motors may occur.

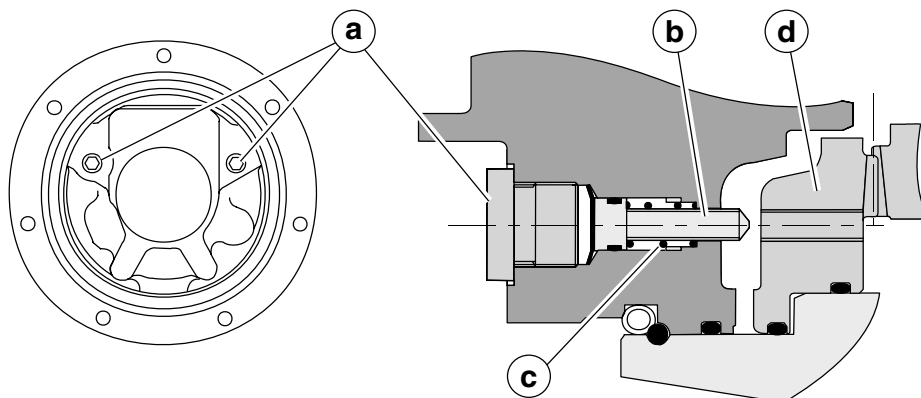

wc_gr002964

4.29 Troubleshooting

Problem / Symptom	Reason / Remedy
ENGINE DOES NOT START	<ul style="list-style-type: none"> • Fuel tank empty. • Wrong type of fuel. • Old fuel. Drain tank, change fuel filter and fill with fresh fuel. • Fuel system not primed. • Fuel filter restricted or plugged. Replace filter. • Battery connections loose or corroded. Battery dead. • Air cleaner element plugged. • Starter motor defective. • Fuel solenoids on engine inoperative. • Starter relay inoperative. • Electrical connections loose or broken.
ENGINE STOPS BY ITSELF	<ul style="list-style-type: none"> • Fuel tank empty. • Fuel filter plugged. • Fuel lines broken or loose. • No spark. (RD 12 only)
NO VIBRATION	<ul style="list-style-type: none"> • Defective switch or poor connection. • Solenoid on vibration valve damaged or disconnected. • Exciter assembly damaged. • Exciter motor coupling damaged or broken. • Exciter motor damaged. • Exciter pump damaged. • Exciter bearings damaged.
NO TRAVEL or TRAVEL ONLY IN ONE DIRECTION	<ul style="list-style-type: none"> • Pin sheared on forward/reverse control. • Control cable loose or broken. • Drive motor damaged. • Drive pump damaged. • Defective relief valve or valves.
NO STEERING	<ul style="list-style-type: none"> • Steering cylinder damaged. • Steering unit damaged. • Steering relief valve stuck or damaged. • Articulation joint lockarm engaged.

5 Technical Data

5.1 Engine

Item no.		RD 12A 0620058 0620320 0620369	RD 12 0620059 0620321	RD 16 0620060 0620127 0620402
Engine				
Engine type		4-stroke, 2 cylinder, air cooled		3-cylinder, 4-cycle, liquid-cooled, diesel engine
Engine make		Honda	Wacker	Lombardini
Engine model		GX 610	WM 650	LDW 1003
Rated power @ 3100/ 3600 rpm	kW (Hp)	11.8 (15.8)/ 13.4 (18.0)	12.3 (16.5)/ 15.3 (20.5)	16.5 (24.5)/ 20.0 (26.8)
Displacement	cm ³ (in ³)	614 (37.5)	653 (39.9)	1028 (62.7)
Spark plug		(NGK) BPR6ES / (NGK) BPR6ES high heat	NGK-BP6ES	--
Electrode gap	mm (in)	0.71-0.79 (0.028-0.031)	0.6-0.7 (0.024-0.027)	--
Engine speed - full load	rpm	3100		3000
Engine speed - idle	rpm	2000		1300
Valve clearance (cold)		0.10-0.16 (0.004-0.006)	0.08-0.115 (0.0031-0.0045)	0.15 (0.006)
intake:	mm (in.)	0.10-0.16 (0.004-0.006)	0.08-0.115 (0.0031-0.0045)	0.20 (0.008)
exhaust:				
Battery	V	12VDC		
Air cleaner	type	Dual element		Dry pleated paper elements
Fuel	type	Regular unleaded gasoline		Diesel
Fuel tank capacity	l (gal.)	23 (6.1)		
Fuel consumption	l (gal.)/hr.	4.9 (1.3)	6.0 (1.35)	3.6 (0.96)
Engine oil	type	10W30 SG, SF/CC, CD		SAE 15W40 Class CD rated
	l (qt.)	1.2 (1.3)		2.4 (2.5)
Coolant capacity	l (gal.)	--	--	4.75 (1.25)

5.2 Roller

Item No.		RD 12A 0620058 0620320 0620369	RD 12 0620059 0620321	RD 16 0620060 0620127 0620402
Roller				
Dry Weight	kg (lb.)	1002 (2171)		1356 (2990)
Curb Clearance: Right Left	mm (in.)	400 (15.7) 208 (8.2)		400 (15.7) 400 (15.7)
Water Tank Capacity	l (gal.)	100 (26.4)		
Outside Turning Radius	m (ft.)	2.44 (8.0)		2.87 (9.4)
Forward / Reverse Speed	km (hr.) / mph	0-8.7 (0-5.4)		0-9.3 (0-5.8)
Gradeability		30%		
Vibration Frequency	vpm	4200		

5.3 Lubrication

Item No.		RD 12A 0620058 0620320 0620369	RD 12 0620059 0620321	RD 16 0620060 0620127 0620402
Lubrication				
Engine Lubrication	type l (pt.)	SAE 10W30 Class SG, SF, or SE rated 1.6 (3.5)		SAE 15W40 Class SD rated 2.5(5.3)
Hydraulic System	type l (gal)	Premium grade, Anti-wear hydraulic fluid 10W30 21.6 (5.7)		
Exciter	type	Mobil XHP222		
Rear Drum Drive Bearing	type qty	Mobil XHP222 2-3 shots with hand-held grease gun		
Front Drum Drive Bearing (RD 16 only)	type	Sealed Bearings—No lubrication required		
Articulated Joint	type qty	Mobil XHP222 2-3 shots with hand-held grease gun		

5.4 Dimensions—RD 12 / RD 16-90 / RD 16 IRH

mm (in.)

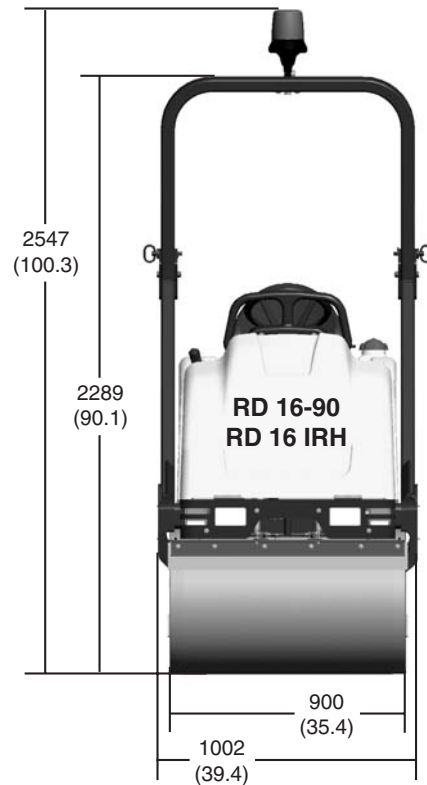
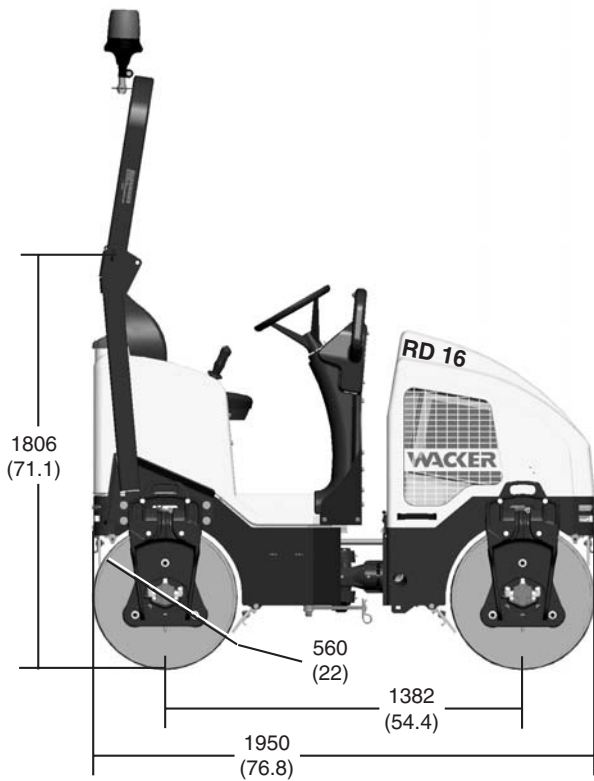
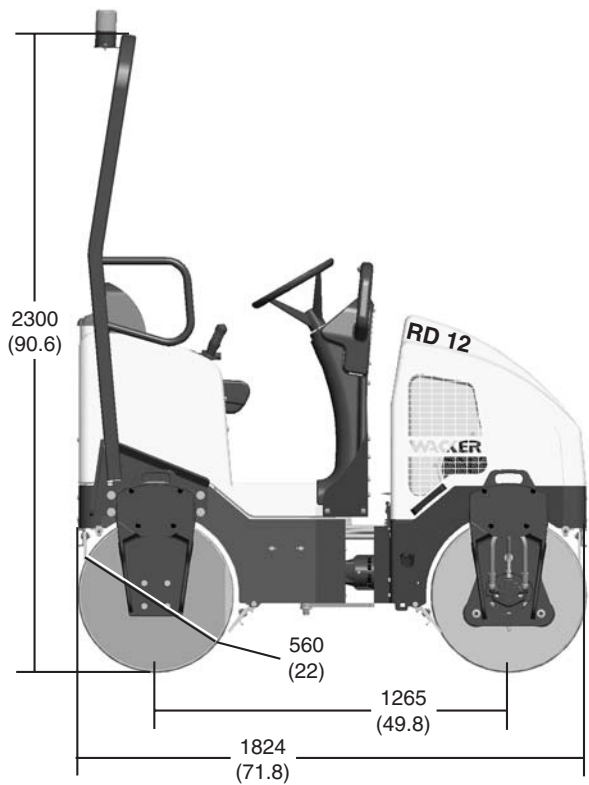

5.5 Dimensions—RD 16-100

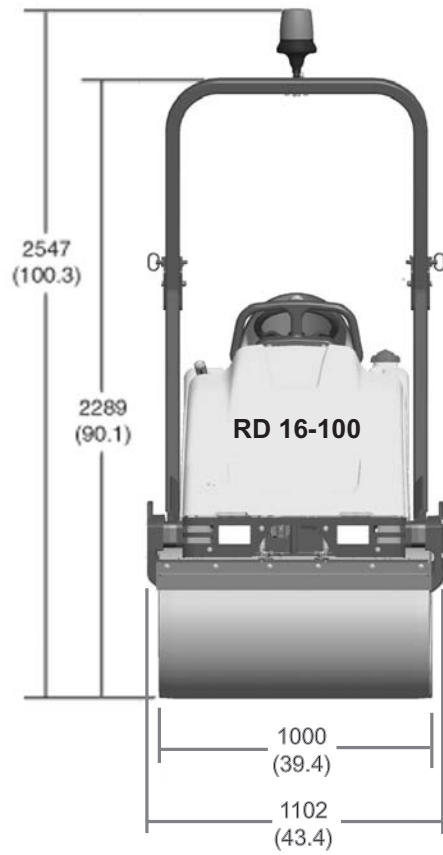
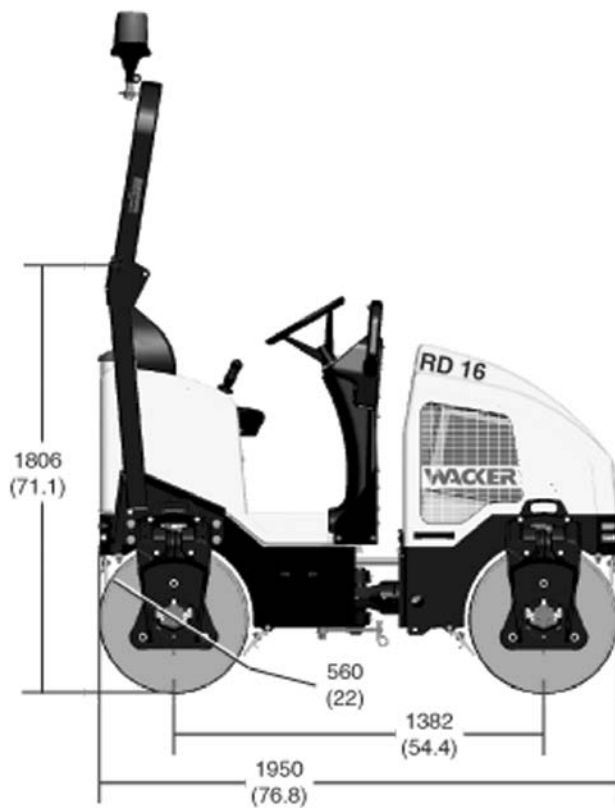

wc_gr004610

5.6 Sound Measurements

The operating sound level, measured per the requirements of Appendix 1, Paragraph 1.7.4.f of the EC-Machine Regulations, is:

- the guaranteed sound power level (L_{WA}):
RD 12 = 102 dB(A), RD 16 = 106 dB(A).
- the sound pressure level at operator's location (L_{pA}):
RD 12 = 85.6 dB(A), RD 16 = 88.1 dB(A).

This sound value was determined according to ISO 3744 for the sound power level (L_{WA}).

5.7 Measurements of Operator Exposure to Vibration

The operator of this machine should expect to be exposed to vibration levels listed below when using the machine in performance of its normally intended function:

- Maximum hand/arm vibration levels are:

$$\text{RD 12} = 1.4 \text{ m/s}^2 \text{ (4.6 ft/s}^2\text{)}$$

$$\text{RD 16} = 2.2 \text{ m/s}^2 \text{ (7.2 ft/s}^2\text{)}$$

These are the representative values of the weighted root mean square (**rms**) acceleration to which the hands and arms are subjected. These weighted **rms** values are measured according to ISO 5349-1.

- Whole body vibration levels do not exceed:

$$\text{RD 12} = 0.22 \text{ m/s}^2 \text{ (0.7 ft/s}^2\text{)}$$

$$\text{RD 16} = 0.3 \text{ m/s}^2 \text{ (1 ft/s}^2\text{)}$$

These are the representative values of the weighted root mean square (**rms**) acceleration to which the whole body is subjected. These weighted **rms** values are measured according to ISO 2631-1.

The results are compliant to the limit and action vibration values (hand/arm and whole body) as specified in European directive 2002/44/EC.

5.8 Hydraulic Schematic—RD 12/RD 12A

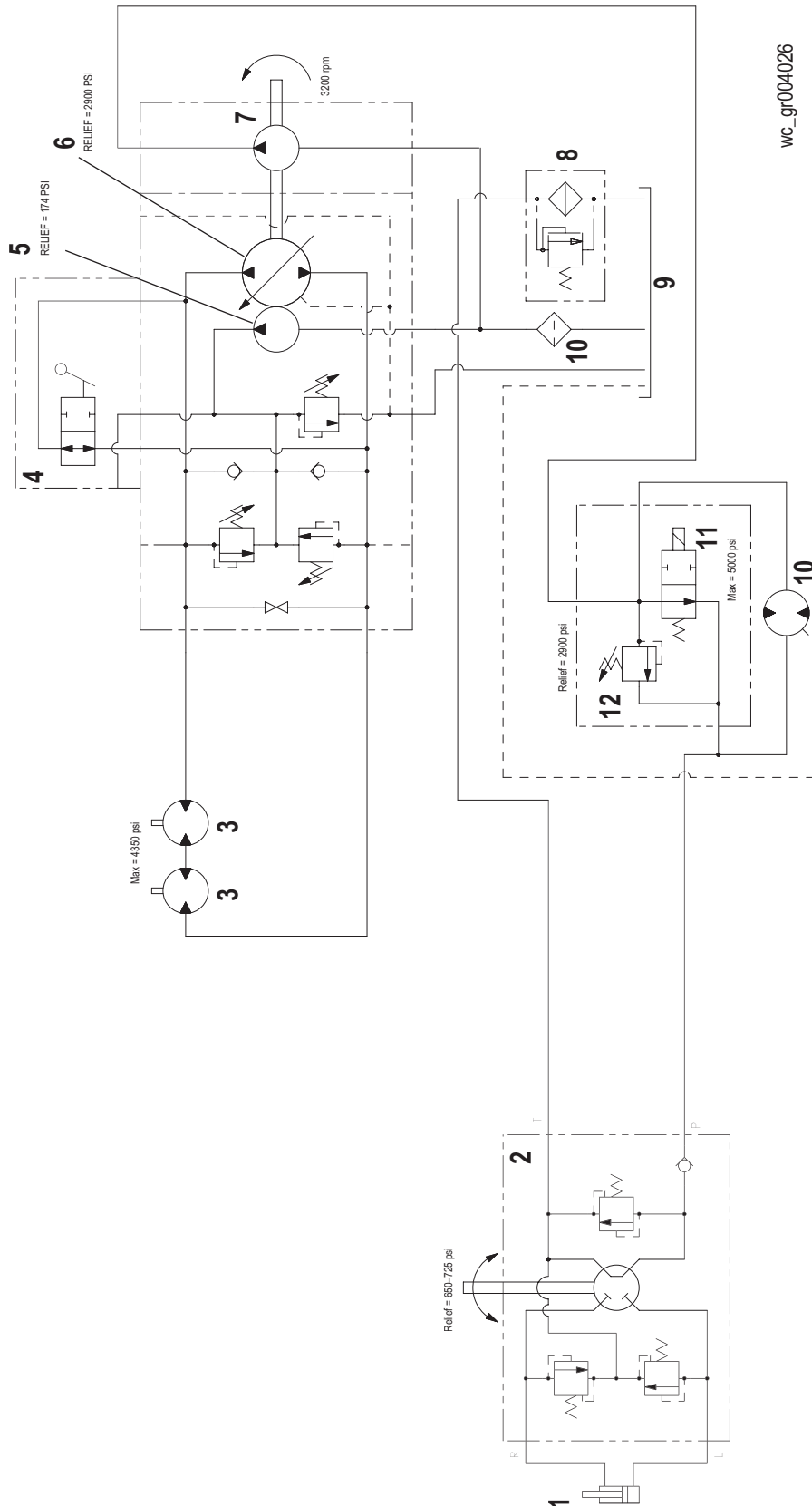

wc_gr004026

5.9 Hydraulic Schematic Components—RD 12/RD 12A

Ref.	Description	Ref.	Description
1	Steering cylinder	8	Return filter
2	Steering unit	9	Tank
3	Drive motor	10	Suction strainer
4	Bypass lever	11	Vibration solenoid valve
5	Charge pump	12	Exciter motor
6	Main pump	13	Pressure relief valve
7	Exciter pump	-	---

5.10 Hydraulic Schematic—RD 16

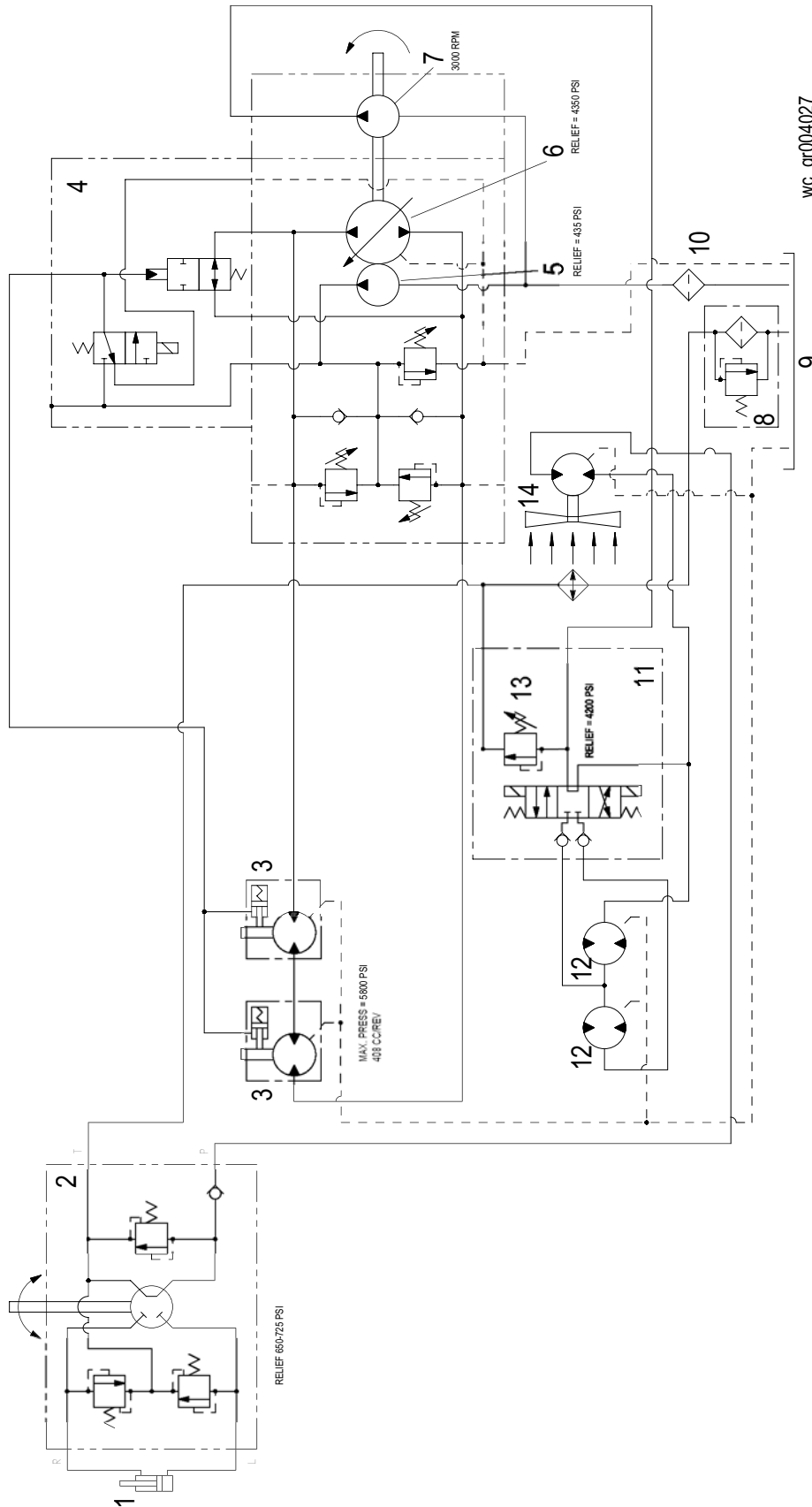

wc_gr004027

5.11 Hydraulic Schematic Components—RD 16

Ref.	Description	Ref.	Description
1	Steering cylinder	8	Return filter
2	Steering unit	9	Tank
3	Drive motor	10	Suction strainer
4	Bypass	11	Vibration solenoid valve
5	Charge pump	12	Exciter motor
6	Main pump	13	Pressure relief valve
7	Exciter pump	14	Fan

5.12 Electric Schematic—RD 12

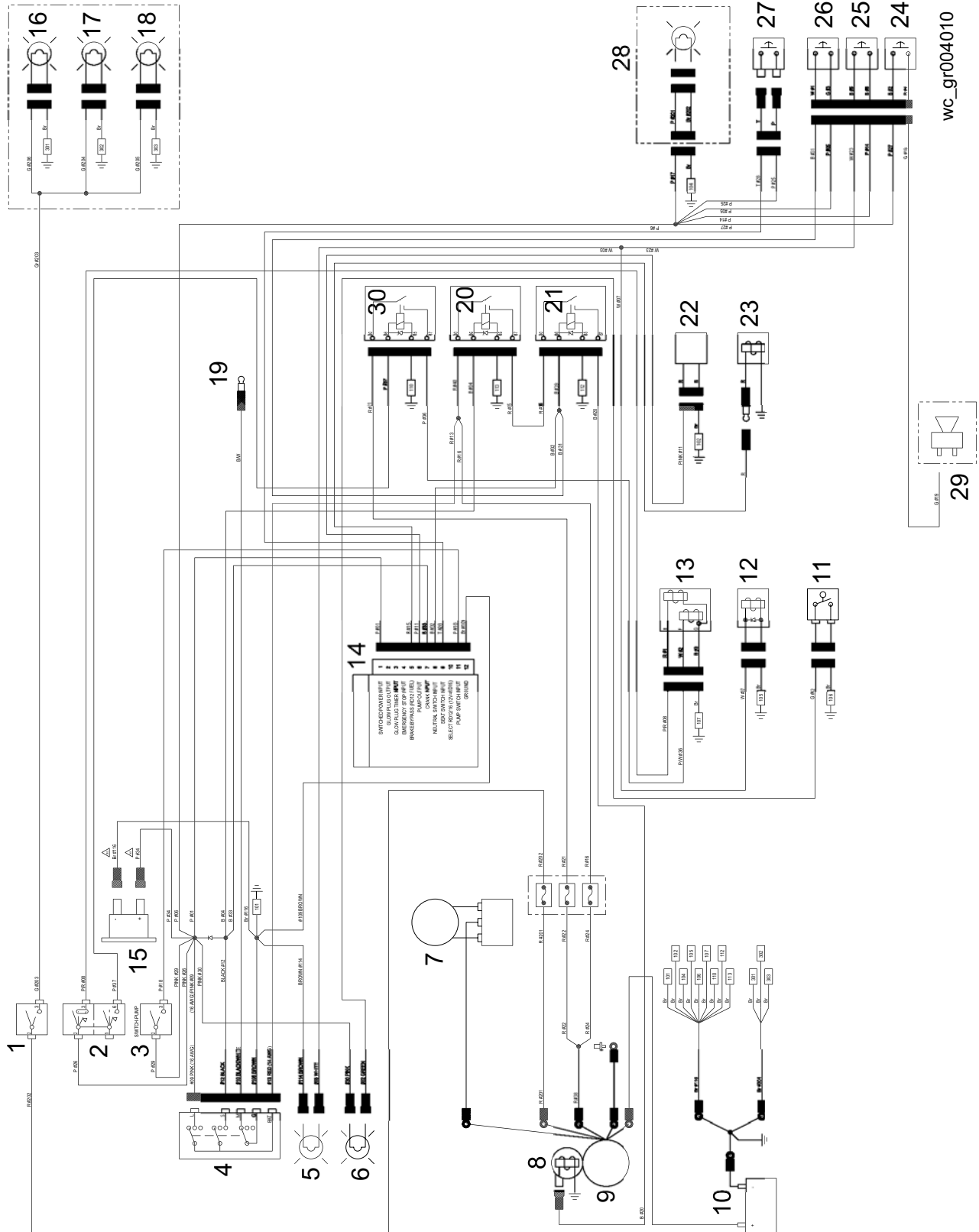

wc_gr004010

5.13 Electrical Schematic Components—RD 12

Ref.	Description	Ref.	Description
1	Work light switch	16	Rear light (optional)
2	Throttle switch	17	Left head light (optional)
3	Pump switch	18	Right head light (optional)
4	Key switch	19	To magneto kill
5	Vibration indicator light (green)	20	Crank relay
6	Low fuel indicator light (amber)	21	Neutral relay
7	Alternator (30A)	22	Spray bar pump
8	Starter solenoid	23	Fuel cutoff solenoid
9	Starter motor	24	Reverse switch
10	Battery	25	Vibration switch
11	Fuel level sensor	26	Neutral switch
12	Vibration solenoid (front)	27	Seat switch
13	Throttle solenoid	28	Strobe light (optional)
14	Pump timer module	29	Backup alarm (optional)
15	Hourmeter	30	Throttle relay

Wire Colors							
B	Black	R	Red	Y	Yellow	Or	Orange
G	Green	T	Tan	Br	Brown	Pr	Purple
L	Blue	V	Violet	Cl	Clear	Sh	Shield
P	Pink	W	White	Gr	Gray	LL	Light blue

5.14 Electrical Schematic—RD 12A

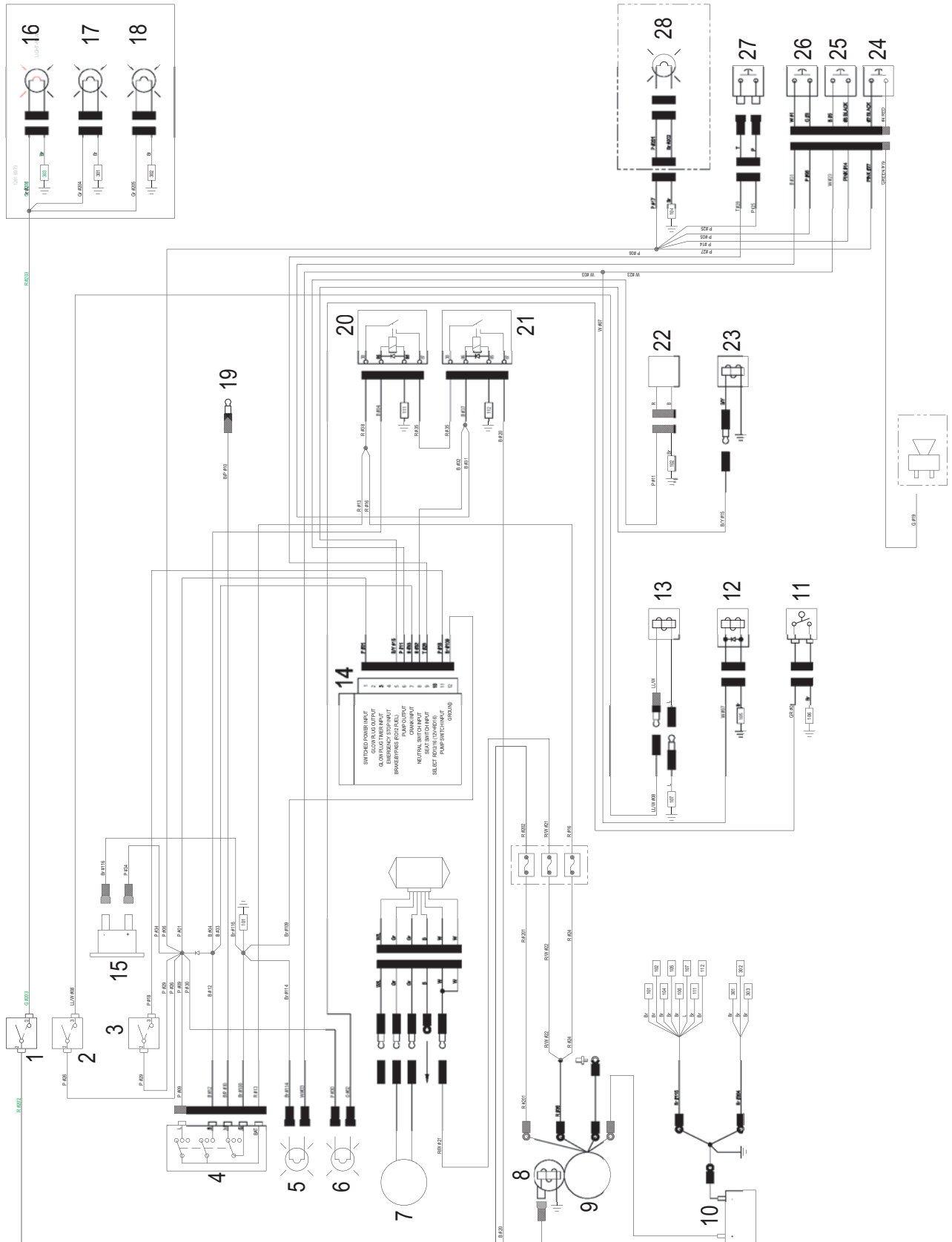

5.15 Electrical Schematic Components—RD 12A

Ref.	Description	Ref.	Description
1	Work light switch	16	Rear light (optional)
2	Throttle switch	17	Left head light (optional)
3	Pump switch	18	Right head light (optional)
4	Key switch	19	To magneto kill
5	Vibration indicator light (green)	20	Crank relay
6	Low fuel indicator light (amber)	21	Neutral relay
7	Alternator (30A)	22	Spray bar pump
8	Starter solenoid	23	Fuel cutoff solenoid
9	Starter motor	24	Reverse switch
10	Battery	25	Vibration switch
11	Fuel level sensor	26	Neutral switch
12	Vibration solenoid (front)	27	Seat switch
13	Throttle solenoid	28	Strobe light (optional)
14	Pump timer module	29	Backup alarm (optional)
15	Hourmeter	-	---

Wire Colors							
B	Black	R	Red	Y	Yellow	Or	Orange
G	Green	T	Tan	Br	Brown	Pr	Purple
L	Blue	V	Violet	Cl	Clear	Sh	Shield
P	Pink	W	White	Gr	Gray	LL	Light blue

5.16 Electrical Schematic—RD 16

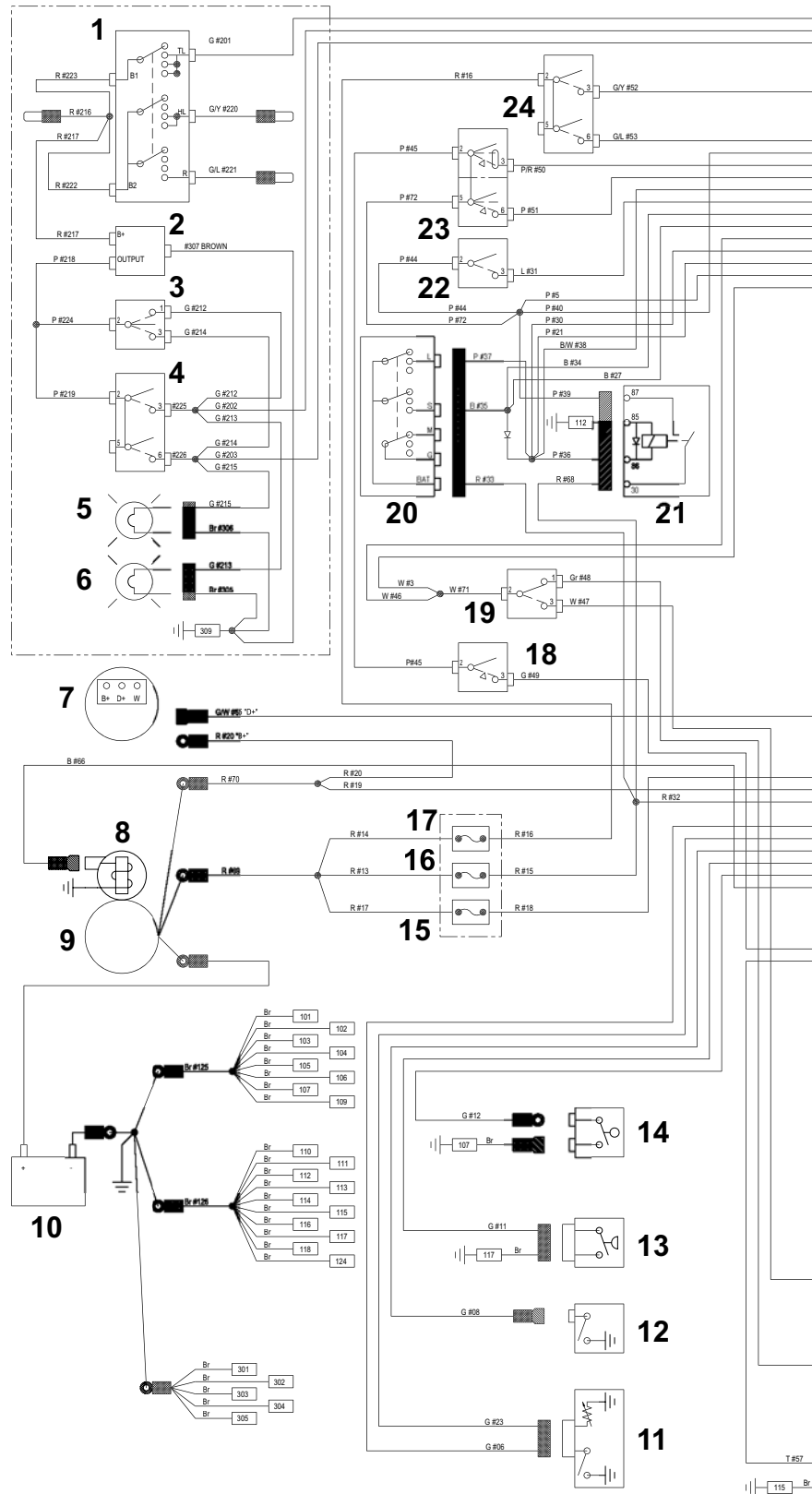

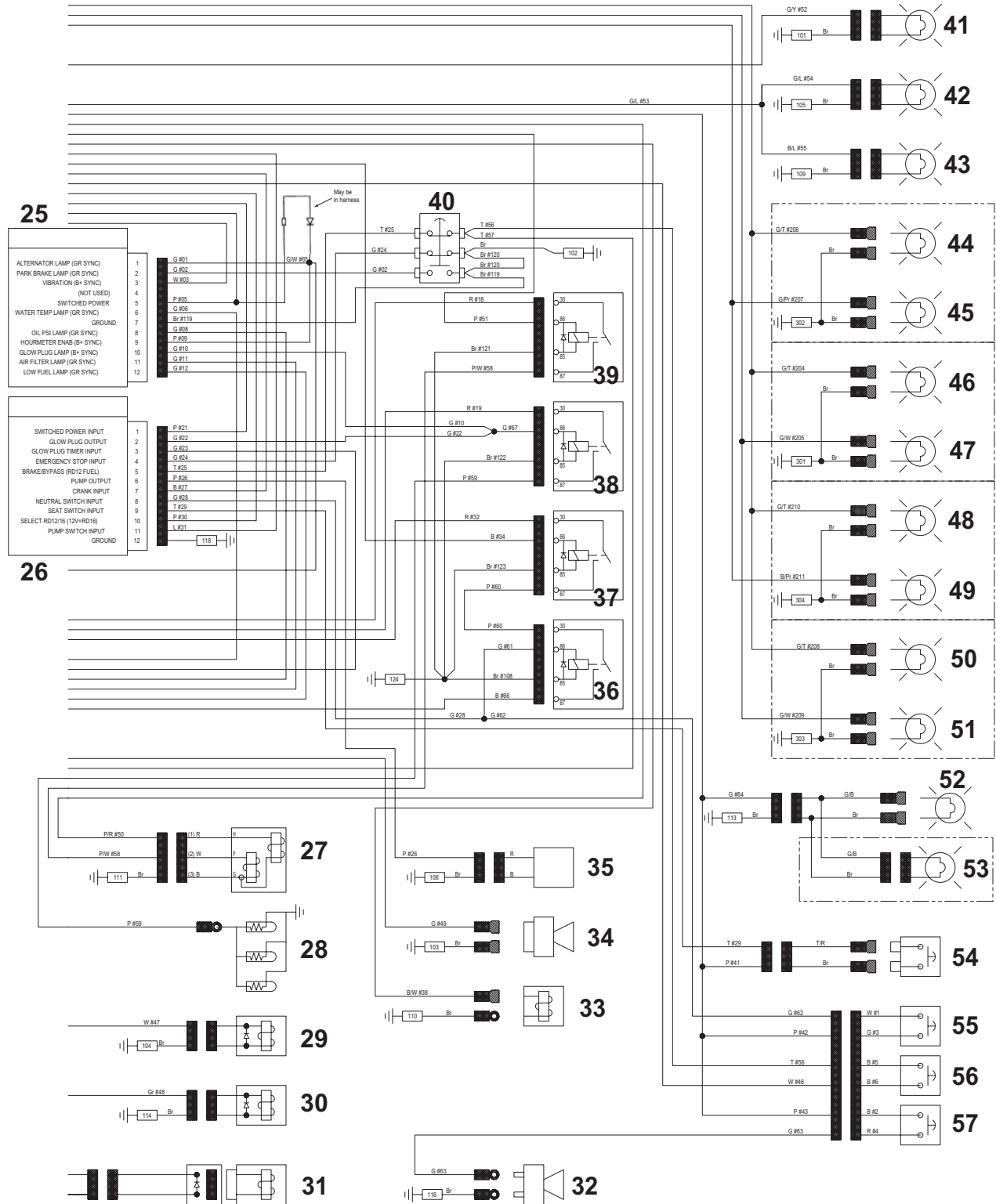

5.17 Electrical Schematic Components—RD 16

Ref.	Description	Ref.	Description
1	Light switch (optional)	29	Vibration solenoid (front only)
2	Flasher	30	Vibration solenoid (front & rear)
3	Turn signal switch	31	Brake and bypass solenoid
4	Hazard switch	32	Reverse alarm
5	Left turn signal light	33	Fuel solenoid
6	Right turn signal light	34	Horn
7	Voltage regulator	35	Spray bar pump
8	Engine crank solenoid	36	Neutral relay
9	Starter	37	Crank relay
10	Battery	38	Glowplug relay
11	Dual-function sensor	39	Throttle relay
12	Oil pressure sensor	40	Parking brake switch
13	Air filter sensor	41	Rear light (left)
14	Fuel level sensor	42	Head light (left)
15	20A fuse	43	Head light (right)
16	30A fuse (main)	44	Front parking light (left) (optional)
17	30A fuse (lights)	45	Front turn light (left) (optional)
18	Horn switch	46	Front parking light (right) (optional)
19	Vibration switch	47	Front turn light (right) (optional)
20	Key switch	48	Rear parking light (left) (optional)
21	Power relay	49	Rear turn light (left) (optional)
22	Pump switch	50	Rear parking light (right) (optional)
23	Throttle switch	51	Rear turn light (right) (optional)
24	Work light switch	52	Beacon
25	Display module	53	License light (optional)
26	Pump timer module	54	Seat switch
27	Throttle solenoid	55	Neutral switch
28	Glow plug engine	56	Vibration switch

ROLLER COMPACTOR

www.aem.org



SAFETY MANUAL

FOR OPERATING AND MAINTENANCE PERSONNEL

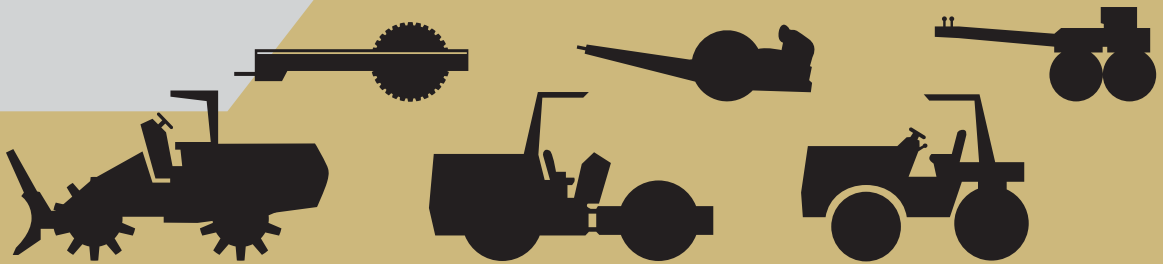

SAFETY ALERT SYMBOL



This Safety Alert Symbol means **ATTENTION** is involved!

The Safety Alert Symbol identifies important safety messages on machines, safety signs, in manuals, or elsewhere. When you see this symbol, be alert to the possibility of personal injury or death. Follow the instructions in the safety message.

Why is SAFETY important to YOU?

3 BIG REASONS:

- Accidents **KILL** or **DISABLE**
- Accidents **COST**
- Accidents **CAN BE AVOIDED**

NOTICE OF COPYRIGHT PROTECTION

AEM Safety Manuals are protected as a copyrighted work with ownership duly registered with the Copyright Office, Washington, D.C. Any reproduction, translation, decompiling or other use of an AEM Safety Manual, or portion thereof, or the creation of deriv-

ative works based on an AEM Safety Manual, without the prior written approval of AEM, is expressly prohibited. Copyright infringement can result in civil and criminal sanctions, damages and other penalties being imposed.

WORD OF EXPLANATION.....	2
FOREWORD.....	4
A WORD TO THE USER	5
FOLLOW A SAFETY PROGRAM	6
PREPARE FOR SAFE OPERATION.....	9
START SAFELY.....	15
WORK SAFELY	18
PARK & SHUTDOWN SAFELY	23
LOAD & UNLOAD MACHINE SAFELY	25
TRANSPORTING SAFELY	26
PERFORM MAINTENANCE SAFELY	28
SPECIAL OPERATING AND MAINTENANCE PRECAUTIONS.....	43
TEST YOUR KNOWLEDGE	47
A FINAL WORD TO THE USER	48

WORD OF EXPLANATION

The following is a partial list of reference material on safe operating practices:

U.S. Department of Labor publishes safety and health regulations and standards under the authority of the Occupational Safety and Health Act for the general construction and mining industries. Its address is: U.S. Department of Labor, 200 Constitution Avenue, NW, Washington, DC 20210.

SAE - Society of Automotive Engineers, Inc., 400 Commonwealth Drive, Warrendale, PA 15096, publishes a list, "Operator Precautions," SAE J153 MAY, 1987.

Association of Equipment Manufacturers, 111 East Wisconsin Avenue, Milwaukee, WI USA 53202, publishes the Roller Compactor Safety Manual and other safety-related material.

This Safety Manual covers many different types of roller compactors ... including steel wheel rollers, vibratory rollers, rubber-tired rollers, segmented pad/sheepsfoot soil compactors and landfill compactors. These may be either self-propelled ride-on, walk-behind or towed rollers. They may be used for the compaction of asphalt, soil, landfill or other materials. Excluded from coverage are vibratory plates and hand rammers.

Regardless of which machine you operate, it is YOUR responsibility to study and understand this Safety Manual, and to see that a copy remains with your machine. The manual begins with your "safety homework," takes you step-by-step through your working day, and ends with maintenance operations.

Manufacturers produce machines with many built-in safety features. Employers provide accident prevention programs. Yet, the ultimate responsibility to operate and maintain your machine with the skill, care and knowledge essential for safety is YOURS.

Do not operate your machine until you have been trained in the use of all operating controls and understand the handling characteristics of the machine.

REMEMBER — SAFETY ... YOURS AND THAT OF THOSE AROUND YOU ... IS UP TO YOU!

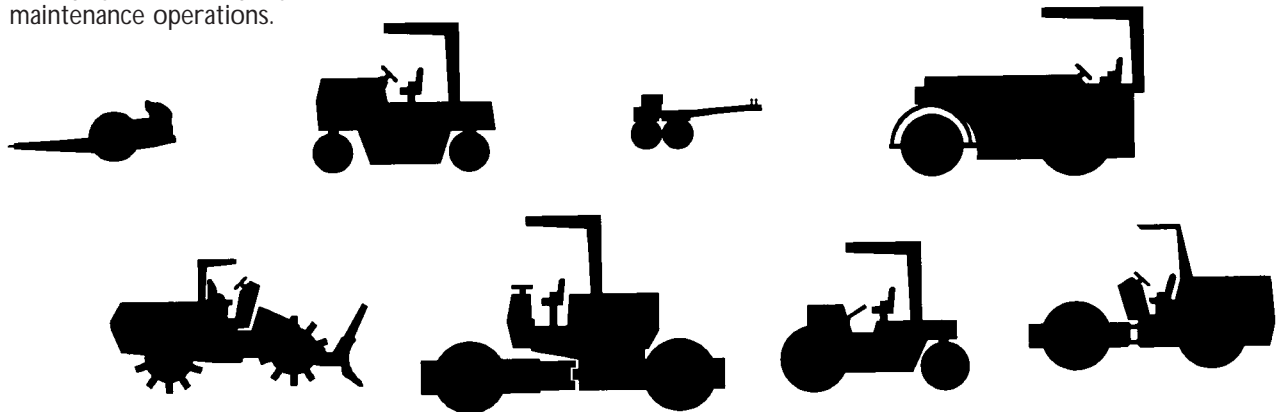

FOREWORD

This safety manual is intended to point out some of the basic situations which may be encountered during the normal operation and maintenance of your machine, and to suggest possible ways of dealing with these conditions.

Additional precautions may be necessary, depending on application, machine type, configuration and attachments used, and conditions at the work-site or in the maintenance area. The manufacturer has no direct control over machine application, operation, inspection, lubrication or maintenance. Therefore, it is your responsibility to use good safe practices in these areas.

The information provided in this manual supplements the specific information about your machine that is contained in the manufacturer's manual(s). Other information which may affect the safe operation of your machine may be contained on safety signs, or in insurance requirements, employer's safety programs, safety codes, local, state/provincial and federal laws, rules and regulations.

If you do not understand any of this information, or if errors or contradictions seem to exist, consult with your supervisor before operating your machine.

IMPORTANT: If you do not have the manufacturer's manual(s) for your particular machine, get a replacement manual from your employer, equipment dealer, or manufacturer of your machine. Keep this safety manual and the manufacturer's manual(s) with your machine.

Unauthorized modifications of machines create hazards. Machines should not be modified or altered unless prior approval is obtained from the manufacturer.

It is your responsibility to read and understand this safety manual and the manufacturer's manual(s) before operating your machine. This safety manual takes you step-by-step through your working day.

Remember that **YOU are the key to safety**. Good safety practices not only protect you but also protect the people around you. Study this manual and the manufacturer's manual(s) for your specific machine. Make them a working part of your safety program. Keep in mind that this safety manual is written for only this type of machine. Practice all other usual and customary safe working precautions, and above all — (FIG. 1)

**REMEMBER — SAFETY IS UP TO YOU
YOU CAN PREVENT
SERIOUS INJURY OR DEATH**



FIG. 1

FOLLOW A SAFETY PROGRAM

KNOW THE RULES

Every employer is concerned about safety. Safe operation and proper maintenance of your machine can prevent accidents. **KNOW** the rules — **LIVE** by them. (FIG. 2)

When starting work at a new site, check with the designated safety coordinator for specific safety instructions. **DON'T LEARN SAFETY THE HARD WAY.**

Know the meaning of all hand signals, signal flags, signs and markings.

Know the traffic rules used at the work site. Know who the signal person is; watch and obey their signals.

Know where the fire extinguishers and first aid kits are kept and how to use them. Know where to get proper aid and assistance when needed.

Use common sense to avoid accidents. If an accident does occur, be prepared to react to it quickly and effectively. **NEVER PANIC.**

Know how to use the emergency communications system to summon help when necessary.



FIG. 2

KNOW WHAT IT IS?

Consult your supervisor for specific instructions on a job, and the personal safety equipment required. For instance, you may need:

- Hard Hat
- Safety Shoes
- Eye Protection
- Face Protection
- Heavy Gloves
- Reflector Vests
- Hearing Protection
- Respirators

Do not wear loose clothing or any accessory — flopping cuffs, untied shoelaces, dangling neckties and scarves, rings, wrist watches, or other jewelry — that can catch on protruding or moving parts or controls. Long hair should be securely bound to prevent entanglement with moving parts. (FIG. 3)

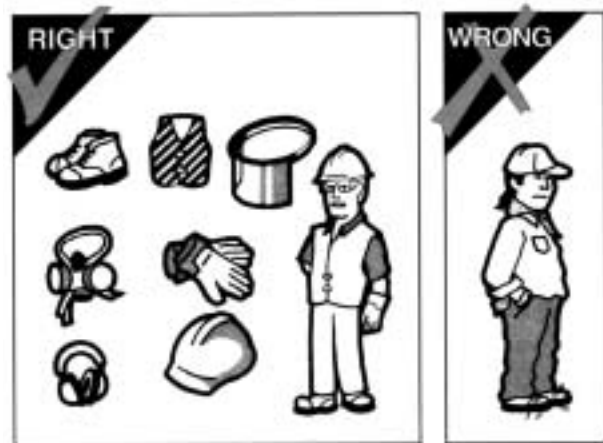

FIG. 3

FOLLOW A SAFETY PROGRAM

BE ALERT!

Know where to get assistance. Know how to use a first aid kit and fire extinguisher or fire suppression system. (FIG. 4)

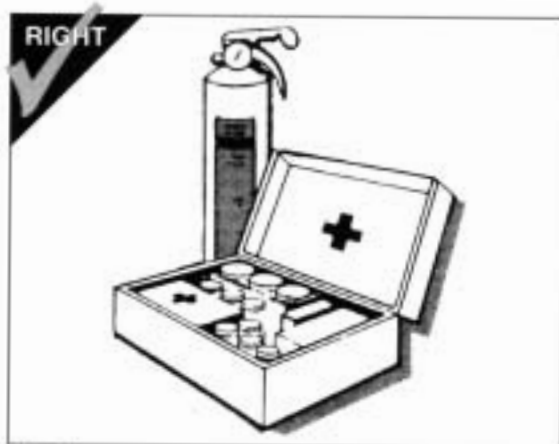

FIG. 4

BE AWARE!

Take advantage of training programs offered.

Safety programs require that one person at each jobsite be assigned the overall responsibility and authority for safety. Know who that person is, and COMMUNICATE.

Know what the jobsite rules are, and FOLLOW THE RULES. Be safety conscious, responsible and reliable. Think about safety BEFORE something happens.

Report unsafe conditions to a supervisor immediately!

BE CAREFUL!

Human error is caused by many factors: carelessness, fatigue, overload, preoccupation, incompatibility between operator and the machine, drugs, and alcohol to name a few. Eliminate these factors BEFORE accidents occur. Damage to the machine can be fixed in a short period of time, but injury, or death has a lasting effect.

FOR YOUR SAFETY AND SAFETY OF OTHERS, ENCOURAGE YOUR FELLOW WORKERS TO ACT SAFELY.

PREPARE FOR SAFE OPERATION

LEARN TO BE SAFE

READ the operator's manual. If one has not been provided, GET ONE AND STUDY IT BEFORE OPERATING THE MACHINE. If you have any questions contact the manufacturer.

Know the positions and understand the functions of all controls before attempting to operate a machine. Know the meaning of all identification symbols on your controls and gauges. (FIG. 5)

Know the location of the emergency shut-down control if the machine is so equipped.

Know the capabilities and limitations of the machine ... such as speed, breaking and steering.

Know the operational and transport dimensions of your machine to avoid inadvertently hitting something during operation or transporting.

Carefully read and follow the instructions on all safety signs on the machine. Keep safety signs in good condition. Replace missing or damaged safety signs.



FIG. 5

NEVER operate a machine which is new to you without first being instructed in its proper operation.

CHECK IT OUT!

Always conduct a pre-shift inspection before operating any machine. Know what safety devices your machine is equipped with ... and see that each item is securely in place and in operating condition. (FIG. 6)

For example:

- Safety Blocks and Locks
- Other Locking Devices
- Lights
- Alarms
- Horn
- Guards and Shields
- Shut-Down Devices
- First Aid Kit
- Fire Extinguishers



FIG. 6

PREPARE FOR SAFE OPERATION

TIRES

Inspect pneumatic tires (if so equipped) for damage, wear, and proper inflation. Never operate with over-inflated or under-inflated tires. (FIG. 7)

Check that all wheel lug nuts are present and tight.

NEVER START OR OPERATE A MACHINE KNOWN OR SUSPECTED TO BE DEFECTIVE OR MALFUNCTIONING.

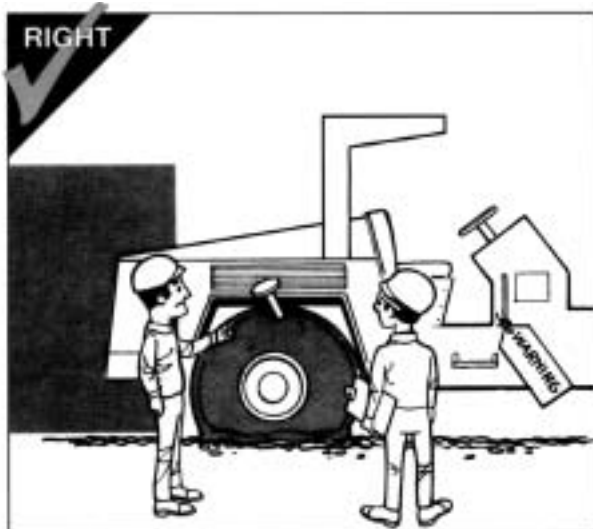

FIG. 7

KNOW YOUR MACHINE

Never operate a machine for which you are not trained or qualified.

Familiarize yourself with pedals, controls and instruments – their locations and function.

To handle controls without slipping, wipe them clean of oil and grease.

Remove tools, supplies and other materials from the working areas and machine walkways – and keep these areas free of trash.

Make sure the items you do carry are not loose or in the way.

ARE REPAIRS MADE?

If your daily check uncovers any item that needs attention – repair, replacement, or adjustment – report it to your supervisor and tag the machine on the start switch and/or other appropriate, prominent location. A minor malfunction could be a sign of a more serious problem if the machine is operated.

PREPARE FOR SAFE OPERATION

FIRE PREVENTION

Never allow flammable fluids or materials to contact hot surfaces.

Never refuel:

- When engine is running
- While smoking
- Near open flames or sparks
- In poorly ventilated area

Never overfill fuel tank or fluid reservoirs. Clean up spills immediately.

Replace fuel cap securely after filling.

Check for fuel, oil and hydraulic fluid leaks. Replace worn or damaged hoses/tubes. After repairs are made, clean the machine before you operate it.

Inspect electrical wiring for worn or damaged insulation. Install new wiring if wires are damaged.

Because ether or other starting fluids are flammable, do not smoke when using them. Always follow the instructions on the container and in the operator's manual for your machine. (See page 19.)

Batteries produce explosive gases. Keep open flame or sparks away. See the manufacturer's instructions when servicing the batteries, when using jumper cables or when using a battery charger. (See pages 36 and 37.)

Remove all trash or debris from the machine. Make sure that oily rags or other flammable material are not stored on the machine. (FIG. 8)



FIG. 8

11

PREPARE FOR SAFE OPERATION

PREPARING TO ROAD THE MACHINE

Know what conditions you will likely encounter:

- Insufficient clearances
- Traffic congestion
- Type of surface
- Steep grades
- Restricted visibility

Determine appropriate warnings to be used. (FIG. 9)
Know whether you will need to be escorted.

If the machine is to travel on a road or highway, refer to the manufacturer's manual(s) for instructions. Become familiar with local laws and ordinances affecting driving on highways. Use "slow moving vehicle" emblem. Make sure flags, lights, and warning signs are in place.



FIG. 9

Select the proper gear before negotiating steep grades. (FIG. 10)

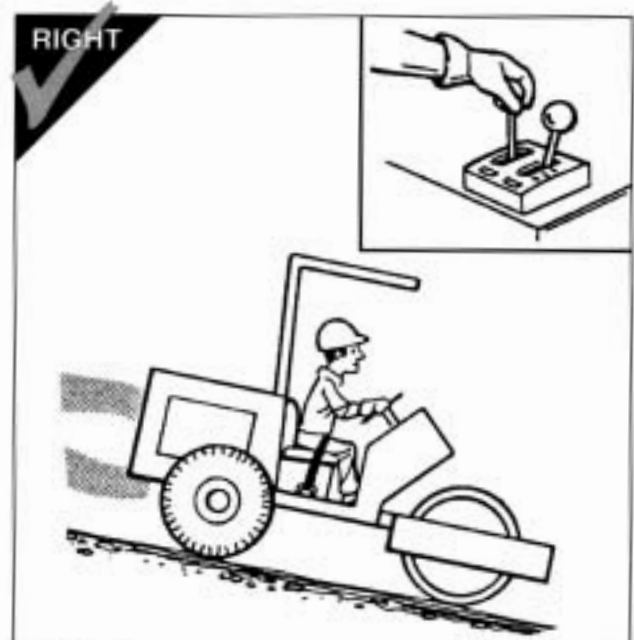

FIG. 10

PREPARE FOR SAFE OPERATION

Before starting, carefully inspect your machine for any evidence of physical damage such as cracking, bending or deformation of plates or welds. Check for cracking or flaking of paint, which may indicate an excessive strain or dangerous crack in the material below. Check for loose, broken or missing parts such as Roll-Over Protective Structure (ROPS) support brackets, vibration isolators, and nuts and bolts. If potentially serious problems are found, do not operate the machine until appropriate repairs are completed.

Check the level of all fluids ... brake, transmission, power steering, engine coolant, hydraulic system, and others. Fill low reservoirs only to the proper level.

Check the various systems (hydraulic, cooling, etc.) for leaks. (FIG. 11) Inspect all plugs, filler caps and fittings for tell-tale signs of leaks. ALWAYS use a flashlight or shielded trouble light when checking ... Never an open flame. Repair any leaks, or have them repaired by authorized service personnel. (See pages 28 through 42 for additional service cautions.)

Check the fuel level and, if low, fill the tank with the proper grade of clean fuel before extended operation (following the instructions on page 34).

A stalled or faltering engine can result in a real hazard when operating on grades, in traffic or in heavily congested areas.

NEVER smoke when checking fuel level or refueling.



FIG. 11

13

PREPARE FOR SAFE OPERATION

BE SURE THE WORK AREA IS SAFE

Before beginning operation, thoroughly check the area for any unusual conditions that could be dangerous. (FIG. 12) Check for hidden holes, drop-offs or overhead obstacles that could be dangerous. Check the clearance under overhead power and phone lines. LOOK UP AS WELL AS DOWN.



FIG. 12

Be observant of other workmen, bystanders and other machines in the area. Be especially careful if trenches, lightpoles, tiles, buildings, etc. are within the effective range of a vibratory compactor. IMPROPER OPERATION COULD RESULT IN DAMAGE OR INJURY.

Remember, the danger of sliding and/or tipping on steep slopes is always present ... regardless of how heavy or "stable" your machine may appear to be. When operating under these conditions, the use of ROPS and seat belts reduces the hazard to operating personnel.

Walk around your machine once more just prior to mounting it – checking for people and objects that might be in the way – then MOUNT PROPERLY USING STEPS AND HANDHOLDS PROVIDED.

Always use seat belts if your machine is equipped with a ROPS.

Just before starting, check all controls ... such as forward and reverse, steering, transmission and throttle to be sure they are in the correct start-up position. (FIG. 13) The parking brake should be applied during the start-up operation.

Check for proper functioning of all operating and shut-down controls.

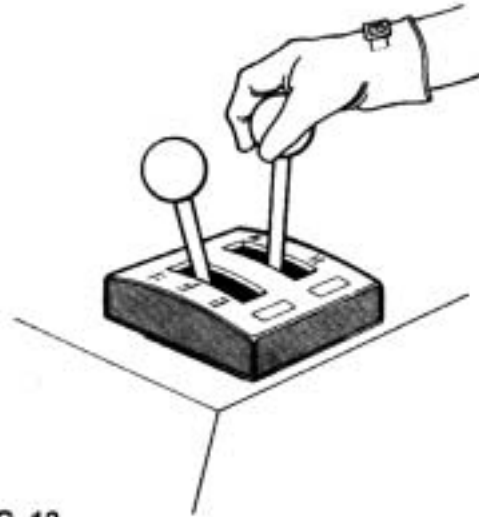

FIG. 13

START CORRECTLY

Know the PROPER starting procedure for your machine. Follow the manufacturer's operation manual ... to the letter.

Then, start your engine.

START SAFELY

IMMEDIATELY AFTER STARTING THE ENGINE ...

- Observe gauges, instruments, and warning lights to ensure that they are functioning and their readings are within the normal operating range. (FIG. 14)
- Be sure work area is safe for test operation of the various controls and attachments.
- Operate all controls: make certain they operate properly, and "feel" right. Accustom yourself to the "feel" of your machine.
- Listen for any unusual noises; smell for any unusual odors; look for any signs of trouble.
- Check all warning and safety devices and indicators.
- If safety-related defects or malfunctions are detected, shut down the machine. Correct it, or notify your supervisor. DO NOT OPERATE UNTIL CORRECTED.

Check operation of service and parking brakes on level ground if possible.

Check service brakes (including hydrostatic brakes, if so equipped) in both forward and reverse operation (FIG. 15) ACCORDING TO THE MANUFACTURERS INSTRUCTIONS.

If an unsafe condition cannot be remedied immediately, notify your supervisor and tag the machine on the start switch and/or other appropriate, prominent location. (See page 28 for Lockout/Tagout procedure.) No machine should be operated if any part is not in safe operating condition. Make certain that any unsafe condition has been satisfactorily remedied.



FIG. 14



FIG. 15

COLD WEATHER OPERATION

Consult the engine manufacturer's operation manual for proper cold weather starting procedure.

When using cold weather starting aids, be sure to follow the engine manufacturer's instructions. (FIG. 16)

After starting, operate all systems slowly and gently until properly warmed up.



FIG. 16

BOOSTER CABLE INSTRUCTIONS

1. Connect positive (+) cable to positive post of discharged battery.
2. Connect other end of same cable to same marked post of booster battery.
3. Connect negative (-) cable to other post of booster battery.
4. Make final connection on stalled vehicle away from battery, either on vehicle frame or engine block.
5. Start vehicle and remove cables in reverse order of connection.

17

WORK SAFELY

REMEMBER THESE RULES

When roading or operating a machine, always stay in the operator's station. NEVER mount or dismount a machine that is moving. Maintain control of your machine at all times.

ALWAYS operate your machine slowly until fully familiarized with its operation.

Constantly check your total work area for potential hazards.

Never JUMP on or off your machine. Use the steps and handholds provided to mount or dismount safely. Maintain three point contact when mounting or dismounting. (FIG. 17)

- Never use controls or levers as hand holds.
- Never jump off the machine.

Look, listen and smell for possible malfunctions. If malfunctioning controls or erratic operation are detected, correct or report them immediately. **DO NOT OPERATE THE MACHINE UNTIL CORRECTED.**

Prevent asphyxiation. If you must operate in a building or other enclosed area, or if your machine is equipped with an enclosed cab, be certain there is adequate ventilation.

Use extra care when refueling. (See page 34 for special precautions.)



FIG. 17

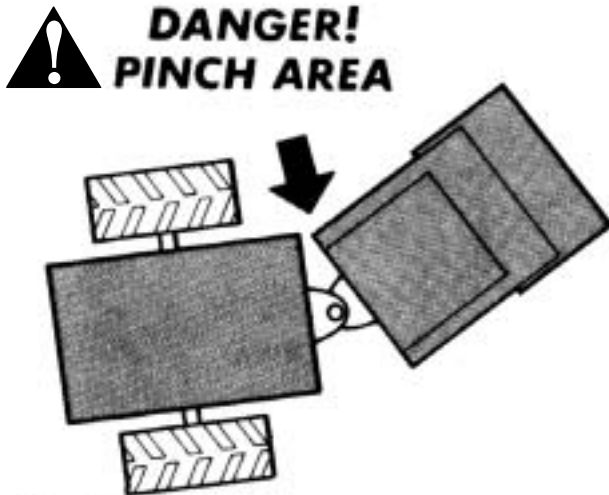

FIG. 18

For maximum safety on machines with more than one operator's position, operate from the position giving the greatest visibility of potential hazards.

NEVER allow unqualified or unauthorized personnel to operate your machine.

NEVER allow other personnel to ride on your machine unless appropriate seating is provided ... and then only if authorized to do so.

NEVER abuse your machine. Misuse or abuse can cause an accident.

NEVER enter or place any part of your body in the "hinge area" or other "pinch" areas of an articulated machine while the engine is running, or when there is any chance another person might start the machine. (FIG. 18)

Give the right-of-way to loaded equipment on haul roads. Maintain a safe distance from personnel, motor vehicles and other machines.

Your safety, and the safety of those around you, is determined by the care and judgment YOU use while operating your machine.

WORK SAFELY

WORKING ON SLOPES

When working on slopes, avoid sidehill travel whenever possible ... rather operate up and down the slope. (FIG. 19 & 20) Remember the danger of sliding and/or tipping on steep slopes is always present ... regardless of how heavy or "stable" your machine may appear to be.

ALWAYS use seat belts IF your machine is equipped with a ROPS.

NEVER allow the engine or machine to overspeed.

When climbing or descending steep grades, ALWAYS select the proper gear BEFORE starting on the slope, to assure adequate power or engine braking.

If your machine has a gear shift, select a low gear. If your machine has a hydrostatic drive, the speed control should be in the slow travel position, close to neutral ... NEVER in the fully displaced position.

On machines that have a gear shift AND a hydrostatic control, BOTH controls must be in their slow travel position.

ALWAYS be sure that manually operated gear type transmissions are fully engaged BEFORE starting onto a grade. DO NOT attempt to change the gear selection while traveling on a grade. See the manufacturer's manual for specific instructions.

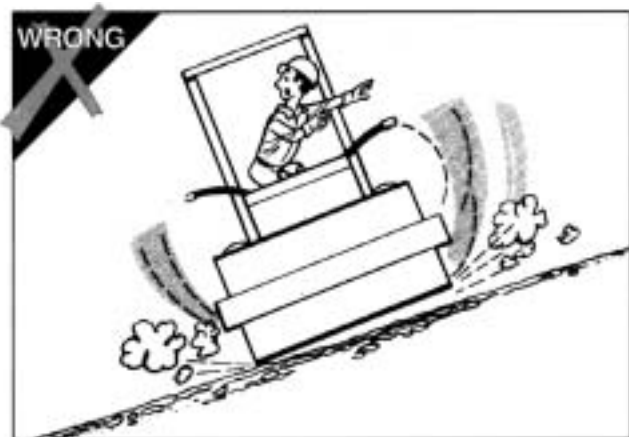

FIG. 19

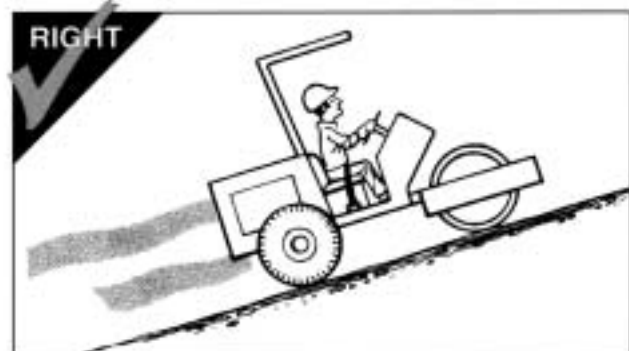

FIG. 20

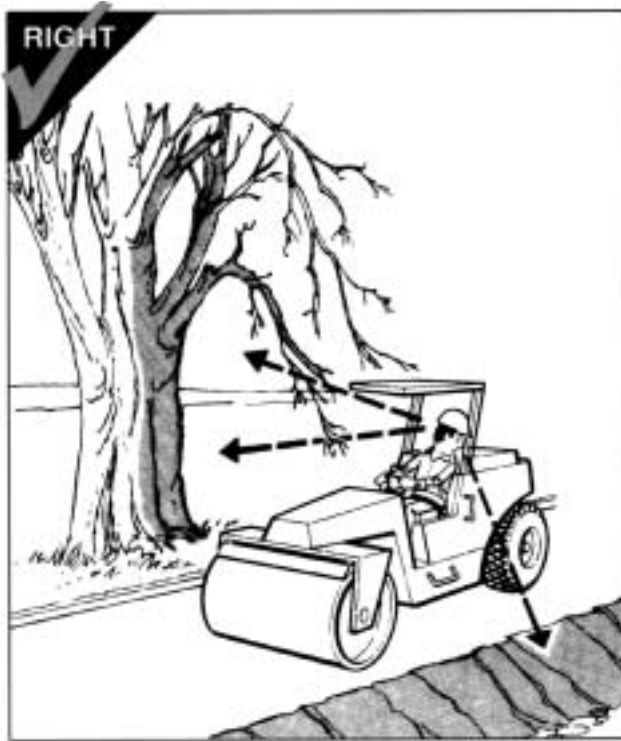

FIG. 21

Avoid operating your machine too close to an overhang, deep ditch or hole. If your machine inadvertently gets close to a tipping condition or drop-off, STOP and get off the machine after applying the parking brake ... plan your moves carefully before proceeding. Reversal is often the best move.

Be alert to potential caving edges, falling rocks and slides.

Check for overhead obstacles that could be dangerous. LOOK UP AS WELL AS DOWN. (FIG. 21)

Be alert to obstacles and excessively rough terrain. Back away from them and go around.

Always travel slowly over rough terrain and hillsides. Maintain a speed consistent with the working conditions.

WORK SAFELY

When traveling on a public road, obey all traffic regulations and be sure that the proper clearance flags, lights and warning signs ... such as the "slow moving vehicle" emblem ... are used. (FIG. 22)

NEVER speed ... and NEVER coast in neutral.

When roading the machine know your approximate stopping distance at any given speed.

NEVER turn corners at excessively high speeds. (FIG. 23)

Always look in all directions before reversing your direction of travel.

Use EXTRA caution when working in close quarters or when traveling through congested areas. Courtesy pays off.

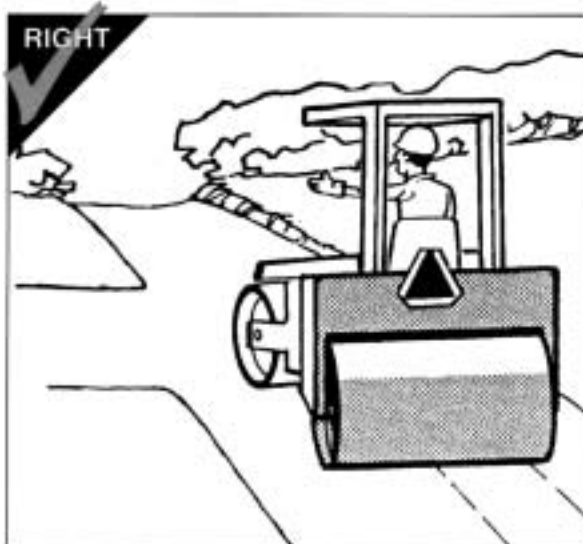

FIG. 22



FIG. 23

PARK AND SHUT DOWN SAFELY

PARK SAFELY

Park in an off the road area, out of traffic, or as instructed. If necessary to park in a traffic lane, use the appropriate flags, barriers, flares, lights and warning signals. Provide advance warning signals in the traffic lane to warn approaching traffic.

Park on level ground whenever possible. (FIG. 25) When not possible, position the machine at right

angles to the slope. Make sure the machine is on a firm footing, and that there is no danger of sliding. Do NOT leave your machine until you are sure it is safely blocked in both directions and parking brakes firmly applied. (FIG. 24)

Lower the blade and all other hydraulically operated attachments (if so equipped) to the ground.

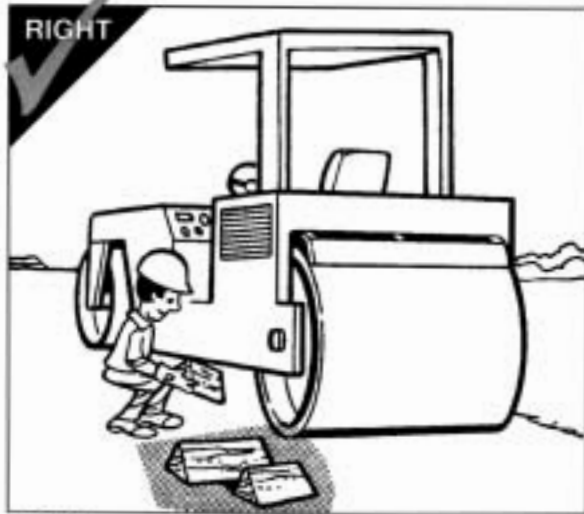

FIG. 24

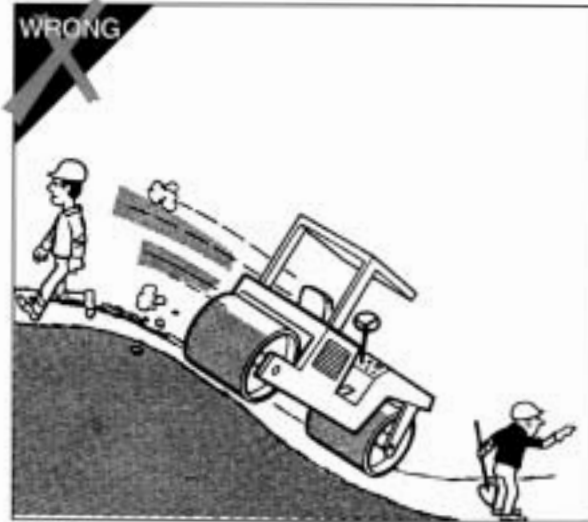

FIG. 25

23

PARK AND SHUT DOWN SAFELY

SHUT DOWN PROPERLY

Know the proper shut-down procedure for your machine. As with the starting procedure, this varies with the type and model of machine.

Follow the manufacturer's operation manual for YOUR machine. Remove the key(s) to prevent unauthorized starting and movement, and position and lock any antivandalism devices.

DISMOUNT PROPERLY

NEVER dismount from your machine until it is fully stopped and the engine is shut off.

NEVER jump off your machine. (FIG. 26) After stopping, use the steps and handholds provided to dismount safely. Maintain three point contact when dismounting.



FIG. 26

LOAD AND UNLOAD MACHINE SAFELY

Loading and unloading machines always involves potential hazards. **EXTREME CAUTION SHOULD BE USED.**

Know the correct loading and unloading procedures for your machine.

All machines are not loaded and unloaded the same way. The procedures recommended by the manufacturer should always be followed.

Several precautions are applicable to all machines:

- NEVER load or unload machine by yourself.
- Keep all non-essential personnel clear of loading and unloading area.
- Load and unload on a level surface.
- ALWAYS use ramps of adequate size and strength. Be sure ramps are sufficiently wide, and long enough to provide a safe loading slope.
- NEVER use ramps that are cracked, damaged, or of questionable strength. (FIG. 27)
- Be sure that the ramps are securely positioned and fastened, and that the two sides are at the same level as one another.

- The ramp surface must provide adequate traction. Be sure the surface is clean and free of grease, oil, ice, and loose material.
- The hauling vehicle should be blocked to prevent movement during loading or unloading of the machine.
- For proper tie-down instructions, see the manufacturer's manual.



FIG. 27

25

TRANSPORTING SAFELY

GENERAL

When towing a machine on a trailer, or a machine equipped with "portability or transport wheels", ALWAYS use a hauling vehicle of sufficient weight, horsepower and braking capacity to maintain proper control.

NEVER attempt to tow a trailer or machine if the hitching devices are of insufficient or questionable capacity, improperly matched in size or shape, or positioned at improper heights.

When towing a machine equipped with portability or transport wheels, ALWAYS follow the manufacturer's towing instructions.

BEFORE TOWING

When connecting a trailer to a hauling vehicle, block under the trailer's tongue before attempting to make the connection. NEVER attempt to lift heavy tongues or move heavy trailers by hand. NEVER get any part of your body under the tongue when hitching or unhitching.

ALWAYS make sure the hitch is properly and securely locked.

ALWAYS use safety chains between the hauling vehicle and trailer or towed machine. Be sure the chains are properly and securely connected ... at BOTH ends. Cross the chains under the tongue when connecting to the hauling vehicle.

ALWAYS make sure electrical and other connections between the hauling vehicle and trailer or towed machine are properly and securely made. After connecting, check the lights for proper operation. If the towed trailer or machine is equipped with brakes operable from the hauling vehicle, check to make sure they are operating properly.

ALWAYS be sure the portability or transport wheels, on machines so equipped, are LOCKED in the lowered position.

Check ALL tires for proper pressure, excessive or abnormal wear, and potentially dangerous cuts, bruises or bulges. Have any problems corrected before proceeding.

TOWING

ALWAYS use EXTRA care when towing a trailer or machine... when maneuvering in tight places, when backing (visibility is reduced, and jackknifing must be avoided), and when towing on steep grades.

Know and obey all local, state and federal laws and regulations.

NEVER travel at speeds above those recommended by the manufacturer.

NEVER allow anyone to ride on a trailer or towed machine. (FIG. 28)

When necessary to disconnect and park a trailer or towed machine, ALWAYS select a location that is level and, if possible, one where children are unlikely to be present. BEFORE disconnecting a trailer, chock the front AND rear of the wheels, and block under the tongue.

See pages 23 through 24 for parking, shut-down procedures and roading machine for transport.

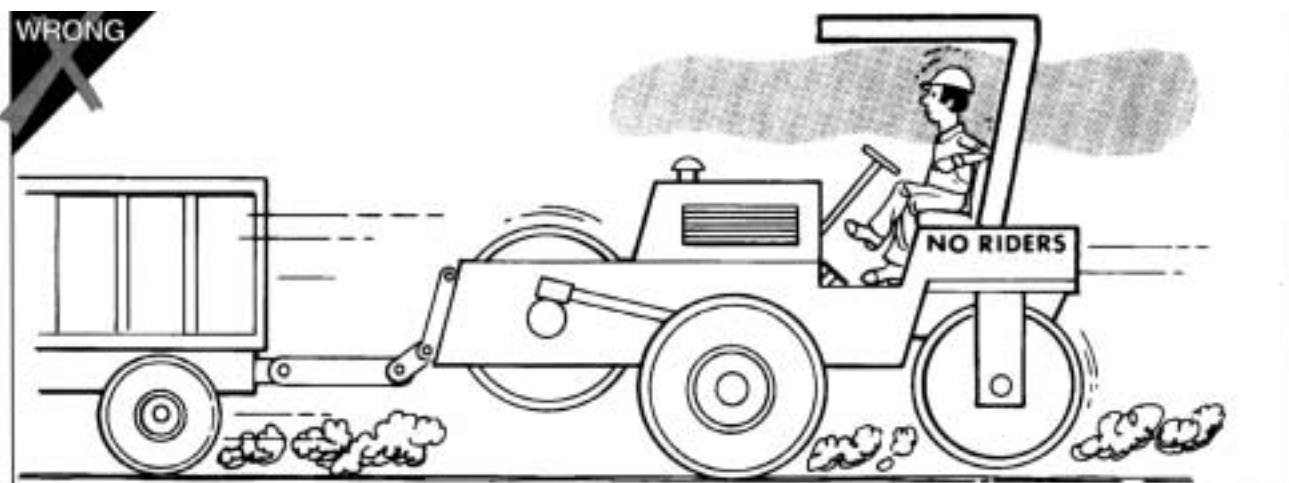

FIG. 28

PERFORM MAINTENANCE SAFELY

GENERAL

Maintenance work can be **hazardous** if not done in a careful manner. All personnel should realize the hazards and strictly follow safe practices.

NEVER perform any work on the equipment unless authorized to do so. (FIG. 29) Before performing any maintenance or repair work, consult the Instruction Manual. Follow the manufacturer's recommended procedures.

BEFORE any maintenance work is begun, review LOCKOUT/TAGOUT procedures. LOCKOUT controls and/or energy source and place a warning label to alert workers of shutdown.

PRIOR to removal of LOCKOUT/TAGOUT, the equipment must be fully operational and all personnel accounted for. Except in cases of emergency, the removal of the LOCKOUT/TAGOUT should be done by the initiating person prior to the return to start-up.

BEFORE doing any major work, or work on the electrical system, disconnect the batteries.

REPLACE all missing or broken guards and panels.

USE proper nonflammable cleaning solvents. Follow solvent manufacturer's instructions.

ALWAYS remove all flammable materials in the vicinity of welding and/or burning operations.

BURNING OR WELDING in the vicinity of acoustical material may release hazardous fumes.



FIG. 29

CLOTHING AND PERSONAL PROTECTIVE ITEMS

Keep hands and clothing well away from engine fan and moving parts while engine is running.

ALWAYS wear appropriate safety glasses, goggles or face shield when working. (FIG. 30) Proper eye protection can keep flying particles from grinding, drilling or hammering operations, or fluids such as fuel, solvents, lubricants and brake fluids, from damaging your eyes. Normal glasses do NOT provide adequate protection.

ALWAYS wear a hard hat and safety shoes. (FIG. 30) ALWAYS wear hearing protectors when exposed to high noise levels for extended periods. ALWAYS wear a respirator when painting or exposed to dusty conditions. ALWAYS keep your pockets free of loose objects which can fall out and drop into



FIG. 30



FIG. 31

machinery. (FIG. 31) Heavy gloves should be worn for many operations.

EXHAUST FUMES

Engine exhaust fumes can cause sickness or death. If it is necessary to run an engine in an enclosed area, use an exhaust pipe extension. If you do not have an exhaust pipe extension, be positive the area is adequately ventilated. (FIG. 32)



FIG. 32

HEAVY PARTS

Handle tools and heavy parts sensibly – with regard for yourself and other persons. Lower items – don't throw or drop them.

ALWAYS use proper hoisting equipment for lifting heavy loads.

PERFORM MAINTENANCE SAFELY

- Keep machine in proper adjustment at all times. Serious injury could result if adjustments are neglected.
- Whenever possible, AVOID working on a machine with the engine running. If the engine must be run to make checks or adjustments, put the transmission in neutral, set the parking brake and chock the drum and wheels securely ... front and rear ... to prevent movement in either direction.
- Personnel can be caught by moving parts when the **guards are removed** for access in making repairs. A repair or maintenance job is not complete until guards, plates and other safety devices have been replaced.
- NEVER put your fingers in open gears or reach through the spokes of a gear.
- Before working on the fuel system, close the fuel shut-off valve. NEVER smoke or use open flames near the machine while working on the fuel system.
- **Remove and store** all tools before resuming operation.

- Before working in the pivot or "pinch" area of an articulated machine, securely attach the steering frame lock to prevent the machine from turning. (FIG. 33) Enter this area only when necessary.
- Connect any other safety locks provided before proceeding with the work.

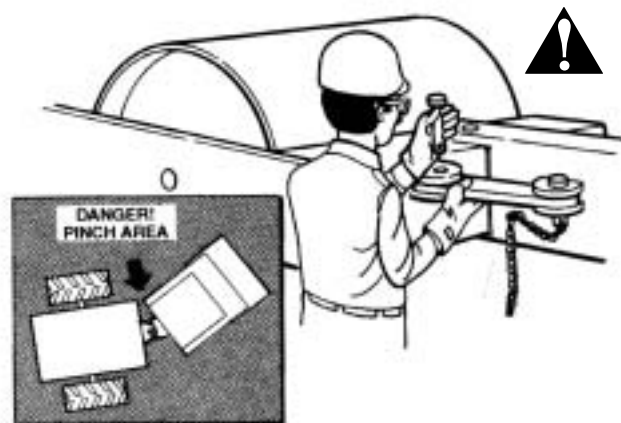

FIG. 33

Before beginning welding or burning operations, drain fuel lines and tank and move all flammable material to a safe distance, and be certain a fire extinguisher is readily available. When welding fuel tanks, either gasoline OR diesel, ALWAYS drain the tank, fill with water, and leave cap off during the welding operation.

All guards, plates and other safety devices must be properly replaced before the machine is returned to service or serious injury to you or other personnel may result.

AVOID burning or welding near acoustical material whenever possible, as **hazardous** fumes may be released. If unavoidable, make sure the area is adequately ventilated, and that a fire extinguisher is ready available.

ALWAYS use authorized replacement parts that meet the machine manufacturer's specifications.

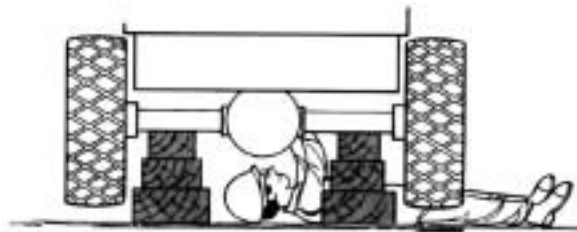

FIG. 34

JACKING AND BLOCKING

ALWAYS lower all movable attachments to the ground or to their lowest position before servicing a machine.

If a machine must be raised for servicing or repairs, ALWAYS block the machine securely. Use axle stands or other rigid supports of ample capacity. NEVER rely solely on the jacks for support. If necessary to work under a machine, be absolutely certain it is adequately supported. (FIG. 34)

WARNING: Never use concrete blocks for supports. They can collapse under even light loads.

When jacking up a machine, use a SUITABLE jack, placed in the proper position, on a solid foundation.

Before working on a machine, chock the drum and wheels securely ... front and rear ... in such a manner as to prevent movement in EITHER direction. Securely attach the steering frame lock to prevent the machine from turning.

PERFORM MAINTENANCE SAFELY

FIRE PREVENTION

Whenever possible use a nonflammable solvent to clean parts. Do not use gasoline or other fluids that give off harmful vapors.

If flammable fluids, such as diesel fuel, must be used, extinguish open flames or sparks and do not smoke.

Store dangerous fluids in a suitable place, in approved containers which are clearly marked. NEVER smoke in areas where flammable fluids are used or stored. (FIG. 35)

Use proper nonflammable cleaning solvents. Follow solvent manufacturer's instructions for use.

Always remove all flammable material in the vicinity of welding and/or burning operations.

ALWAYS keep the floor in the work area clean and dry. Oily, greasy floors can easily lead to falls. Wet spots, especially near electrical equipment, can be hazardous. (FIG. 35)

Know where fire extinguishers are kept – how they operate – and for what type of fire they are intended.

Check readiness of any fire detectors and fire suppression systems.



FIG. 35

FIRE PREVENTION CHECKLIST (FIG. 36)

- Remove debris such as rags, coal dust, oil, leaves, pine needles.
- Check and repair fuel and hydraulic leaks.
- Check and repair damaged wiring.
- Prevent hose and electrical wire harness abrasion.
- Tighten loose clamps and fittings.
- Secure loose wiring.
- Make sure guards and protective covers are in place.
- Make sure fire extinguisher is available and operable.

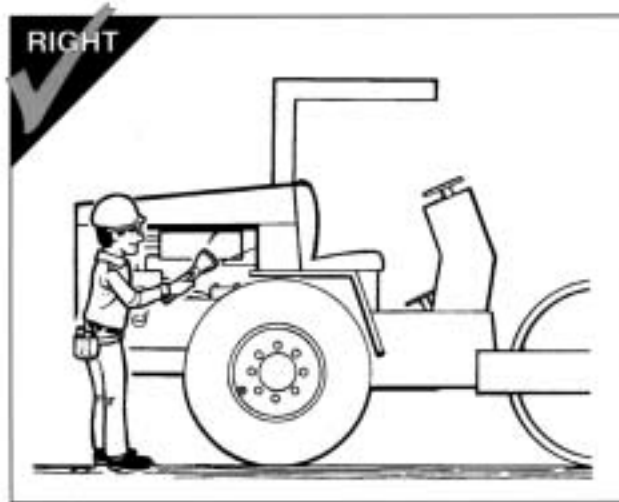

FIG. 36

PERFORM MAINTENANCE SAFELY

REFUELING (FIG. 37)

Precautions

When refueling, the following precautions must be followed:

- Add proper type and grade of fuel only when machine is not running and machine is parked with no one in the cab.
- Fuel in a well-ventilated area.
- Turn off all electrical switches.
- Turn off cab heaters.
- Open lights, lighted smoking materials, flames, or spark producing devices shall be kept at a safe distance while refueling.
- Keep fuel nozzle in contact with tank being filled, or provide a ground to prevent static sparks from igniting fuel.
- Do not spill fuel on hot surfaces.
- Any spillage shall be cleaned immediately.

- Do not start engine until fuel cap is secured to the fuel tank and people are clear of the machine.
- ALWAYS make sure fuel, oil, hydraulic fluid and water are added to their proper tanks.

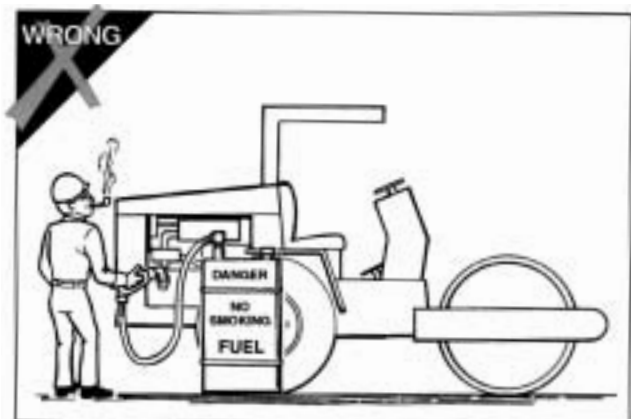

FIG. 37

SERVICING COOLING SYSTEM

When checking coolant level:

- Stop the engine and let the engine and radiator cool before checking. (FIG. 38)

If an overheated engine requires a shutdown:

- **Wait for the radiator to cool.** The hot pressurized coolant can cause burn injuries. Never add coolant to an overheated system.
- **Overheating is a symptom of trouble.** Stop the engine and have the trouble corrected before serious damage occurs.
- If it is necessary to check an overheated engine use a heavy cloth, gloves, heavy clothing and safety glasses or goggles to protect yourself. Stand to the side, turn your face away, and slightly loosen the cap. Wait until the sound stops before removing the cap.



FIG. 38

35

PERFORM MAINTENANCE SAFELY

SERVICING BATTERIES

Always wear safety glasses and gloves when working with batteries.

Before removing a battery, turn off all electrical equipment, then disconnect the negative (-) battery cable first. Before installing a battery, turn off all electrical equipment, then connect the positive (+) battery cable first.

To prevent sparking at the posts when using a battery charger, always turn the charger off or disconnect it from its power source before connecting or disconnecting charger leads to battery posts. Caps on all cells should be left on and the vent caps would be covered with a wet cloth.

Do not short across the battery terminals. The spark **could** ignite the gases.

BOOSTER CABLE INSTRUCTIONS (FIG. 39)

1. Connect positive (+) cable to positive post of discharged battery.
2. Connect other end of same cable to same marked post of booster battery.
3. Connect negative (-) cable to other post of booster battery.
4. Make final connection on stalled vehicle away from battery, either on vehicle frame or engine block.
5. Start vehicle and remove cables in reverse order of connection.



FIG. 39

BATTERY SERVICING

To prevent a battery explosion: (Fig. 40)

- **Maintain** the electrolyte at the recommended level. Check level frequently. Add distilled water to batteries only before starting up, never when shutting down. With electrolyte at the proper level, less space is available for gases to accumulate in the battery.
- **Use a flashlight** to check the electrolyte level. Never use a flame. (Fig. 41)
- **Do not short** across the battery terminals. The spark could ignite the gases.

Battery acid will **burn skin**, eat holes in clothing, and may **cause blindness** if splashed into eyes. If you spill acid on yourself flush skin immediately with lots of water. Apply baking soda to help neutralize the acid. If acids gets in your eyes, flush immediately with large amounts of water and seek proper medical treatment immediately.

When servicing batteries, remember that a lead-acid storage battery generates (when charging or discharging) hydrogen and oxygen – a very explosive mixture. A spark of flame could ignite these gases.



FIG. 40



FIG. 41

37

PERFORM MAINTENANCE SAFELY

HYDRAULIC SYSTEMS

NOTE: Hydraulic Systems have “special features”. Some of the features affecting your safety are listed below.

Pressure can be maintained in hydraulic and air circuits long after the engine has been shut down. This pressure can cause hydraulic fluid or items such as pipe plugs to “shoot out” at high speed if pressure is not released correctly. **Release system pressure** before attempting to make adjustments or repairs.

Consult the manufacturer's instructions for correct procedure.

Before disconnecting **hydraulic fluid** lines, be sure you:

- Shut off engine.
- Always release any air pressure (supercharge) on the hydraulic reservoir.
- Move pedals and control levers repeatedly through their operating ranges to relieve all pressures.

Pressurized hydraulic fluid can penetrate the skin and **cause serious injury**. Therefore, be sure all connections are tight and that lines, pipes, and hoses are in good condition before starting the engine.

Fluid escaping from a small hole can be almost invisible. Use a piece of cardboard or wood, instead of your hands, to search for suspected leaks. (FIG. 42)



FIG. 42

HYDRAULIC SYSTEMS (CONT'D)

If you are struck by escaping **hydraulic fluid under pressure**, serious injury can occur if proper medical treatment is not administered immediately.

During operation, hydraulic fluid and air in an **unvented hydraulic tank** becomes heated and will tend to expand. This will raise the pressure inside an unvented hydraulic tank. If the filler cap is removed rapidly, the pressure in the tank can force the oil out of the tank very rapidly. **The hydraulic fluid may be very hot and may cause severe burns.** Always relieve tank pressure before removing the cap completely. Consult the manufacturer's instructions for the correct procedure.

When adding fluid to any system, be sure to use the fluid recommended by the manufacturer. Certain fluids, when mixed, may destroy seals causing loss of control and possible personal injury.

Keep hydraulic relief valve settings set to the manufacturer's recommendations. **Excessive pressures** could result in structural or hydraulic failures. Low pressure could result in loss of control. Either condition could cause **personal injury or death.**

Be sure the engine is stopped and machine is properly locked out and controls tagged, before working on a machine. Only run engine when it is essential, as in the case of pressure adjustments, lubrication, or tests. Follow the manufacturer's recommendations when making adjustments. Never resume operation until satisfactory adjustments have been made. **The operator must** follow the mechanic's instructions when adjustments are being made or machine is being serviced.

39

PERFORM MAINTENANCE SAFELY

TIRE INSPECTION

Recommended air pressure **must be maintained** in every tire. Daily checks assure that inflation is correct. If your periodic check discloses a tire that is continuously losing air, a leak is indicated and must be repaired. (FIG. 43)

During your pressure checks, also inspect for:

- Objects wedged between or embedded in tires.
- Missing valve caps and wheel lugs.
- Cuts, tears, and breaks that may need repair.
- Abnormal or uneven wear.
- Damaged or poor fitting rim or rim flanges.
- Projecting body hardware, loose fender bolts, spring clips – anything that could contact a tire.

Do not burn or weld on wheels or rims.



FIG. 43

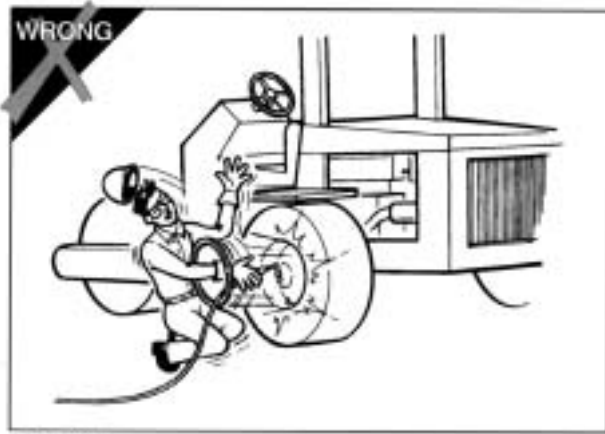

FIG. 44

PNEUMATIC TIRES

Changing tires or adding air can be a hazardous business. Special tools and procedures are required for changing off-highway tires.

Explosion and separation of a tire and/or rim parts can cause serious injury or death. (FIG. 44) Always follow the manufacturer's recommendations or see your tire supplier.

TIRE PRESSURE

Check tire pressure before starting operation. An air pressure rise during operation is normal and should NOT be reduced. Overloads or over-speeds may produce increased tire pressures due to heat. Never bleed tires. Reduce your load – or speed – or stop until tires cool.

ADD AIR

From a distance – with air chuck clipped on the tire valve – and with extension hose that permits you to stand behind tread. (FIG. 45) Always use a tire cage or equivalent for protection.

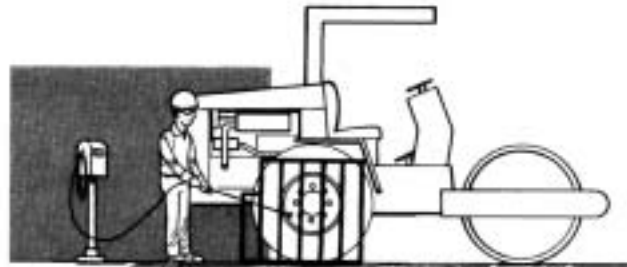

FIG. 45

PERFORM MAINTENANCE SAFELY

ROPS (Roll-Over Protective Structures)

Periodically inspect ROPS for cracks and loose mounting hardware.

Replace all missing, deteriorated or worn rubber parts.

If it becomes necessary to remove a ROPS, reinstall it only on the same machine, in its original position. (FIG. 46)

NEVER alter the ROPS in any way without the written approval of the manufacturer.

NEVER cut holes in or weld on ROPS without the manufacturer's approval.

NEVER attempt to repair a damaged ROPS – it must be replaced with a new unit, approved for that machine.

Periodically inspect seat belts for wear, tear, deterioration or excessive dirt. Replace them if necessary.

AIR CONDITIONERS

NEVER attempt to weld on or near air conditioners. Poisonous gas may be formed when refrigerant gas is exposed to a flame or excessive heat.

Maintenance and repair of air conditioners ... except for very minor repairs or servicing ... must be done only by an experienced air conditioner or refrigeration technician. (FIG. 47)



FIG. 46



FIG. 47

SPECIAL OPERATING AND MAINTENANCE PRECAUTIONS

PARKING AND TRANSPORTING

ALWAYS select a level area to park in and, if possible, one where children are unlikely to be present. ALWAYS chock the front AND rear of the roller ... even if leaving the machine unattended for short periods.

ALWAYS use EXTRA care when towing a roller ... when maneuvering in tight places, when backing (visibility is reduced, and jackknifing must be avoided), and when operating on grades. NEVER operate a towed roller on steep grades or side slopes, as the possibility of tipping or loss of control is greater when towing a roller.

NEVER allow anyone to ride on a towed roller. And, unless absolutely necessary, never permit anyone in the "pinch" area between the towing vehicle and the towed roller.

When necessary to disconnect and park a towed roller, ALWAYS select a location which is level and, if possible, one where children are unlikely to be present. BEFORE disconnecting, ALWAYS chock the front AND rear of the roll, and block under the tongue.

Extreme care should be exercised when loading or unloading a walk-behind roller. It is generally best to stand behind and to one side rather than directly behind a machine being propelled up or down a ramp.

If the roller is designed to hang from the tailgate of a vehicle when being transported, ALWAYS be certain the hook brackets meet the roller manufacturer's specifications.

Special precautions must also be exercised when loading or unloading, transporting or servicing a towed roller. Consult your manufacturer's manual for specific details.

43

SPECIAL OPERATING AND MAINTENANCE PRECAUTIONS

FOR TOWED ROLLERS

Most general safety precautions covered earlier in this manual are also applicable to towed roller operation. Many other SPECIAL precautions must, however, be taken. Study your manufacturer's manual(s) relative to special considerations when towing. If you have questions or concerns, consult the manufacturer or your dealer.

ALWAYS use a tow tractor of sufficient weight, drawbar horsepower and braking capacity to properly control the towed roller. Proper weight balance and distribution is also essential.

ALWAYS block under the tongue of the towed roller BEFORE attempting to connect it to the towing vehicles or machine. NEVER attempt to lift heavy tongues or move towed rollers by hand. NEVER get any part of your body under the tongue when hitching or unhitching.

ALWAYS make sure the hitch pin is of the proper size, and securely locked in place before towing. (FIG. 48) If safety chains are provided, make sure they are properly and securely connected ... at BOTH ends. Cross the chains under the tongue when connecting to the towing vehicle. If electrical or hydraulic connections are required, make sure the connections are properly and securely made.

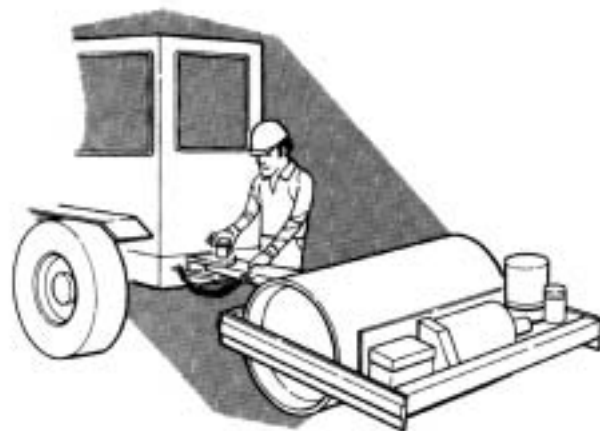

FIG. 48

SPECIAL OPERATING AND MAINTENANCE PRECAUTIONS

FOR LANDFILL COMPACTORS

General

Operators of landfill compactors should carefully handle fill materials that could be picked up and thrown by the wheels, become lodged in the machine, or that are highly flammable.

Frequent checks should be made for wire, cable or other material wound around the axle members. Remove them immediately.

Travel with the blade as low as possible.

Maintain good operator visibility – keep all mesh and windows free of accumulated materials that reduce visibility.

When parking the machine, ALWAYS lower the blade.



FIG. 49

FIRE PROTECTION

Maintain fire extinguishers and fire protective systems in good working order. ALWAYS recharge extinguishers, or replace with a fully charged unit immediately after use.

Check for, and remove, any waste material accumulation above belly pans and behind protective doors and grills. Accumulations are a fire hazard. (FIG. 49)

SPECIAL OPERATING AND MAINTENANCE PRECAUTIONS

FOR WALK-BEHIND ROLLERS

Start-Up

NEVER attempt to operate a walk-behind roller before being thoroughly familiar with the manufacturer's operating instructions. If you have any questions or uncertainty, consult the manufacturer and/or his dealer BEFORE attempting to operate it.

ALWAYS follow the manufacturer's instructions for starting the engine. All controls MUST be in the correct position BEFORE attempting to start the engine (for example, the shift lever must be in neutral).

Starting fluid is NOT recommended when hand starting an engine. The engine may kick back.

OPERATION

When operating a walk-behind roller, ALWAYS exercise extreme care to avoid having your feet or clothing caught under the dolly wheels or roll. When possible, stand behind and to one side of the machine rather than directly behind it. Particular care must be exercised when operating near obstructions, on slippery surfaces, grades and side slopes. (ALWAYS wear slip resistant safety shoes or boots.)

NEVER ride on a walk-behind roller unless it is designed to accommodate riders and an appropriate seat is provided.

NEVER attempt to shift on a grade if the roller has a mechanical transmission.

NEVER operate a walk-behind roller in unshored trenches or near steep, unsupported banks. The vibrations could cause a cave-in.

Uneven grades can cause the handle to raise or lower unexpectedly, striking the unwary operator. (FIG. 50)

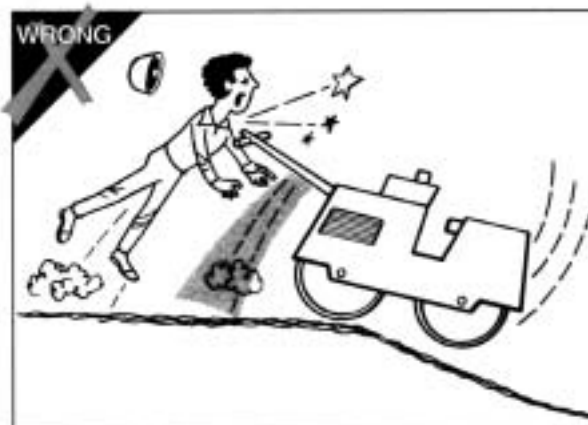

FIG. 50

Do you understand this AEM SAFETY MANUAL AND ITEMS SUCH AS ...

- Your safety program?
- Your machine manufacturer's manual(s)?
- Proper clothing and personal safety equipment?
- Your machine's controls, warning signs and devices, and safety equipment?
- How to properly inspect, mount, and start your machine?
- How to check your machine for proper operation?
- Your work area and any special hazards that may exist?

- Proper operating procedures?
- Proper parking, shutdown, and dismounting procedures?
- Proper maintenance procedures?
- Proper loading and unloading procedures for transporting?
- Under what conditions you should not operate your machine?

If you do not understand any of these items, consult with your supervisor BEFORE operating your machine!

A FINAL WORD TO THE USER

Remember that YOU are the key to safety. Good safety practices not only protect you but protect the people around you.

You have read this safety manual and the manufacturer's manual(s) for your specific machine. Make them a working part of your safety program. Keep in mind that this safety manual is written for only this type of machine.

Practice all other usual and customary safe working precautions, and above all –

**REMEMBER
SAFETY IS UP TO YOU
YOU CAN PREVENT SERIOUS
INJURY OR DEATH**

This manual is another in a series on the safe operation of machinery published by AEM.
For additional publications visit our web site at www.aem.org.



Association of Equipment Manufacturers

Toll free 1-866-AEM-0442

e-mail aem@aem.org

www.aem.org

**EC DECLARATION OF CONFORMITY
CE-KONFORMITÄTSERKLÄRUNG
DECLARACIÓN DE CONFORMIDAD DE LA CE
DÉCLARATION DE CONFORMITÉ C.E.**

WACKER CORPORATION, N92 W15000 ANTHONY AVENUE, MENOMONEE FALLS, WISCONSIN USA

AUTHORIZED REPRESENTATIVE IN THE EUROPEAN UNION BEVOLLMÄCHTIGTER VERTRETER FÜR DIE EUROPÄISCHE GEMEINSCHAFT REPRESENTANTE AUTORIZADO EN LA UNIÓN EUROPEA REPRÉSENTANT AGRÉÉ AUPRÈS DE L'UNION EUROPÉENNE	WACKER CONSTRUCTION EQUIPMENT AG Preußenstraße 41 80809 München
---	--

hereby certifies that the construction equipment specified hereunder / bescheinigt, daß das Baugerät / certifica que la máquina de construcción / atteste que le matériel :

1. Category / Art / Categoría / Catégorie

**Vibrating Ride-On Rollers
Fahrergesteuerte Vibrationswalzen
Rodillos Vibrantes con Conductor Montado
Rouleaux Compacteurs Vibrants à Conducteur Porté**

2. Type / Typ / Tipo / Type

RD 16

3. Item number of equipment / Artikelnummer / Número de referencia de la máquina / Numéro de référence du matériel :

0620060, 0620127

4. Net installed power / Absolute installierte Leistung / Potencia instalada neta / Puissance installée nette :



20 kW

Has been sound tested per Directive 2000/14/EC / In Übereinstimmung mit Richtlinie 2000/14/EG bewertet worden ist / Ha sido ensayado en conformidad con la norma 2000/14/CE / A été mis à l'épreuve conforme aux dispositions de la directive 2000/14/CEE :

Conformity Assessment Procedure / Konformitätsbewertungsverfahren / Procedimiento para ensayar conformidad / Procédé pour l'épreuve de conformité	Name and address of notified body / Bei folgender einbezogener Prüfstelle / Oficina matriculadora / Organisme agréé	Measured sound power level / Gemessener Schall- leistungspegel / Nivel de potencia acústica determinado / Niveau de puissance acoustique fixé	Guaranteed sound power level / Garantierter Schalleleistungspegel / Nivel de potencia acústica garantizado / Niveau de puissance acoustique garanti
Annex VIII / Anhang VIII Anexo VIII / Annexe VIII	BSI, 389 Chiswick High Road, London W4 4AL United Kingdom	105 dB(A)	106 dB(A)

and has been produced in accordance with the following standards:
und in Übereinstimmung mit folgenden Richtlinien hergestellt worden ist:
y ha sido fabricado en conformidad con las siguientes normas:
et a été produit conforme aux dispositions des directives européennes ci-après :

**2000/14/EC
2002/88/EC
89/336/EEC
98/37/EEC
EN 500-1
EN 500-4**

William Lahner
Vice President of Engineering

Greg Orzal
Manager, Product Engineering

10.01.07

Date / Datum / Fecha / Date

WACKER CORPORATION

